

REMEDIATION STRATEGY
PROPOSED RESIDENTIAL DEVELOPMENT
HERBERT ROAD
NEWPORT

Prepared for:
Riversee Limited

March 2015

Job No: 12032/RS

REPORT TITLE : **Remediation Strategy : Proposed
Residential Development, Herbert Road,
Newport**

REPORT STATUS : **Final**

JOB NUMBER : **12032/RS**

DATE : **March 2015**

PREPARED BY :
(R. Howells)

REVIEWED BY :
(L. Dow)

APPROVED BY :
(Dr. G. C. Lake)

Executive Summary

An area of land off Herbert Road, Newport, is to be residentially developed.

In order to comply with current Government directives and the FCA approved by NRW a large section of the development site needs to be raised to a finished floor slab level of 9.95m AOD, which is between 2.5-2.75m above existing levels. This operation will be undertaken in two stages, firstly filling the site to 8.80m AOD utilising material stored upon an adjacent site and then filling the site to 9.95m FFL during the main residential development works.

Riversee Limited is proposing to raise the site to 8.8m AOD before passing on the site to the developer, who will then raise the site further to a finished level of 9.95m AOD.

Investigation of the site was undertaken by Terra Firma (Wales) Limited. The details of the investigation were reported in March 2013 (Geo-environmental and Geo-technical Report No. 12032). In March 2014 additional testing of groundwater was performed.

Terra Firma (Wales) Limited has subsequently been commissioned to prepare a Remediation Strategy for the site. The proposed remediation measures for the site are:

- 1. Cover of site with between up to 2.75m of imported fill (intended to raise site above flood plain).***
- 2. Cover is to include subsoil and topsoil material in garden and landscaped areas. A minimum of 600mm of clean imported fill (topsoil/subsoil) is required in garden and landscaped areas.***
- 3. Monitoring and management of any soils if disturbed and excavated at the location of TP7 to protect against asbestos fibres.***
- 4. Current minimum requirements is the installation of a 2000 gauge membrane suitable for protection against ground gas, radon gas and PCB vapours in all new buildings. Passive under-floor venting and taping and sealing of all joints will also be required. Dependant on further on-site flux box gas monitoring more robust gas protection measures may be required.***
- 5. New water supply pipes to be chosen in accordance with UKWIR Report Ref No 10/WM/03/21 'Guidance for the Selection of Water Supply Pipes to be used in Brownfield Sites'.***
- 6. Additional assessment of groundwater quality during and immediately following placement of fill by Riversee Limited***

All works carried out on site should be documented and recorded, and reported to Newport City Council Environmental Protection and National Resources Wales in the form of a Validation Report.

Any unexpected ground conditions or contamination identified during site development should be inspected and appropriately investigated by a geo-environmental engineer. This may include suspension of site works until the details and severity of any contamination has been established and the potential risks to human health assessed.

TABLE OF CONTENTS

Section 1 Introduction and Proposed Development

- 1.1 Limitations and Exceptions

Section 2 Summary of Terra Firma (Wales) Limited Geotechnical and Geo-environmental Report

- 2.1 Site Works
- 2.2 Ground Conditions
- 2.3 Foundation Solution
- 2.4 Contamination Screening
- 2.5 Gas Monitoring
- 2.6 Human Health and Environmental Risk Assessment
 - 2.6.1 Human Health
 - 2.6.2 Aquatic Environment

Section 3 Proposed Site Remediation

- 3.1 Remediation Summary
- 3.2 Importation of Fill For Engineering Purposes
 - 3.2.1 Fill Materials – Riversee Limited
 - 3.2.2 Fill Materials – Proposed Developer
- 3.3 Importation of Soils For Garden and Landscaped Areas
- 3.4 Gas and Vapour Protection
- 3.5 Asbestos Management and Monitoring – In-situ Soils
- 3.6 Potable Water Supply
- 3.7 River Usk and Groundwater

Section 4 Validation Report

Tables

- Table 2.1 Summary of Ground Conditions
- Table 2.2 Summary of Contaminants of Concern in Soil
- Table 2.3 Summary of Contaminants of Concern in Groundwater
- Table 2.4 In-situ Gas Monitoring Results
- Table 3.1 Soil Determinants and Guideline Values - Imported Engineered Fill Material
- Table 3.2 Leachate Assessment Criteria
- Table 3.3 Soil Determinants and Guideline Values- Imported Soils

Annexes

- Annex A Drawing Detailing Area to be Filled to 8.8m AOD by Riversee Limited

SECTION 1 Introduction and Proposed Development

An area of land off Herbert Road, Newport is to be residentially developed.

In order to comply with current Government directives and the FCA approved by NRW a large section of the development site needs to be raised to a finished floor slab level of 9.95m AOD, which is between 2.5-2.75m above existing levels. This operation will be undertaken in two stages, firstly filling the site to 8.80m AOD utilising material stored upon an adjacent site and then filling the site to 9.95m FFL during the main residential development works.

Riversee Limited is proposing to raise the site to 8.8m AOD before passing on the site to the developer. This area of fill is detailed in the drawing provided in **Annex A**.

In order to raise levels materials are to be imported and placed as engineered fill.

Terra Firma (Wales) Limited has been commissioned to prepare a Remediation Strategy for the site.

The objective of the Remediation Strategy is to address any human health risks and any risks to the aquatic environment previously identified on site, and to set out measures required to ensure that the planned earthworks and import of soils does not create a risk to human health or impact upon the surrounding environment.

1.1 Limitations and Exceptions

Riversee Limited has requested that a Remediation Strategy be prepared.

This report has been prepared for the sole internal reliance of Riversee Limited. This report shall not be relied upon or transferred to any other parties without the express written authorisation of Terra Firma (Wales) Limited. If an unauthorised third party comes into possession of this report they rely on it at their peril and the authors owe them no duty of care and skill.

The report represents the findings and opinions of experienced geo-environmental and geo-technical consultants. Terra Firma (Wales) Limited does not provide legal advice and the advice of lawyers may also be required.

It is not within the scope of Terra Firma (Wales) Limited to:

- Provide Method Statements and Risk Assessments for site preparation and handling and control of soils containing asbestos.
- Design, install and validate the pipes for potable water supply beneath the site.

SECTION 2 Summary of Terra Firma (Wales) Limited Geotechnical and Geo-environmental Report

2.1 Site Works

Investigation of the site was previously undertaken by Terra Firma (Wales) Limited. This included the proposed development area to which this Remediation Strategy refers (south of the drainage ree), and the area north of the drainage ree.

The details of the investigation were reported on in March 2013 (Geo-environmental and Geo-technical Report No. 12032).

The site investigation was carried out between the 31st of October and the 8th of November 2012 comprising 19 trial pits and six cable percussive boreholes and three mini percussive boreholes.

In March 2014 additional testing of groundwater was performed.

2.2 Ground Conditions

The ground conditions encountered beneath the site can in general be summarised as shown in **Table 2.1**.

Table 2.1 Summary of Ground Conditions		
Depth (m)	Thickness (m)	Stratum
GL - 0.20/3.30	0.20/3.30	MADE GROUND
0.30 - 3.90/10.30	2.20/8.40	Soft grey and brown mottled CLAY
3.90/7.1 - 4.10/8.60	0.60/2.30	PEAT
4.10/8.60 - 5.90/9.70	0.00/1.80	SAND & GRAVEL (intermittent)
5.90/10.30 10.00/12.70	- 0.50/4.10	Firm becoming very stiff red brown gravelly CLAY
10.00/12.70 - >12.90	-	MUDSTONE

The basal Sand & Gravel layer was not encountered in BH1, BH2, BH4 and BH5.

Very loose red brown silty SAND and very soft red sandy SILT was encountered between 6.20m and 7.00m and 7.00m and 8.80m respectively.

Soft grey sandy SILT was encountered between 6.20m and 9.10m.

2.3 Foundation Solution

Construction of shallow traditional foundations upon soft clay bands beneath the site would lead to high total and differential settlements.

Precast concrete driven piles founded within the underlying very weak red brown and grey mudstone with a suspended floor slab were therefore recommended.

2.4 Contamination Screening

During the intrusive investigation, small disturbed soil samples were collected for contamination screening. Groundwater wells were installed and groundwater samples were also retrieved for testing. Samples from the drainage reen were taken and analysed in June 2013.

Testing of soil and water samples for a standard suite of metals, inorganics and organics was undertaken as well as for asbestos, polycyclic aromatic hydrocarbons (PAH), petroleum hydrocarbons and polychlorinated biphenyls (PCBs)

A number of substances tested for were found to be above their respective threshold levels in soil on the proposed development site. These exceedances are summarised in **Table 2.2** below.

Table 2.2 Summary of Contaminants of Concern in Soil			
Hole and depth (m bgl)	Chemical	Guideline (mg/kg)	Exceedance (mg/kg)
TP2 0.90m	Cyanide	8	10
TP8 0.50m	Benzo(a)anthracene	3.1	13
	Benzo(a)pyrene	0.83	11
	Benzo(b)fluoranthene	5.6	9
	Chrysene	6	13
	Dibenzo(a,h)anthracene	0.76	1.6
	Indeno(1,2,3-c,d)pyrene	3.2	7.5
TP4 0.70m	Benzo(a)pyrene	0.83	0.90
TP7 0.20m	Benzo(a)pyrene	0.83	1.90
	Chrysotile – Loose Bundles	-	-
TP9 1.00m	Benzo(a)pyrene	0.83	1.30
TP10 0.80m	Benzo(a)pyrene	0.83	1.50
TP13 0.60m	PCB	0.01	0.16
	2,4,4'-Trichlorobiphenyl	0.01	0.12
	2,2',5,5'-Tetrachlorobiphenyl	0.01	0.05

As seen in **Table 2.2** above, the occurrence of asbestos identified by Terra Firma was limited to one location, TP7, where chrysotile bundles at 0.2m depth were noted.

2.4 Contamination Screening (Continued)

Substances found to be elevated in groundwater and ree water are summarised in **Table 2.3** below.

Table 2.3 Summary of Contaminants of Concern in Groundwater			
Borehole	Chemical	Threshold (mg/l)	Exceedance (mg/l)
BH1 (08.01.2013)	Aliphatic C16-C21	0.01	0.11
	Aliphatic C21-C35	0.01	0.14
BH2 (08.01.2013)	Aliphatic C16-C21	0.01	0.037
	Aliphatic C21-C35	0.01	0.19
BH6 (08.01.2013)	Aliphatic C16-C21	0.001	0.03
	Aliphatic C21-C35	0.001	0.011
Reen (Upstream)	Aliphatic C16 - C21 Aliphatic C21 - C35 Aromatic C10 - C12 Aromatic C21 - C35 Fluoranthene	0.01 0.0001	0.021 0.17 0.018 0.062 0.00013
BH5 (06.03.2014)	Zinc	0.125	0.16

2.5 Gas Monitoring

The site is underlain by made ground of up to 3.3m thickness and the area north of the development site (north of the drainage reed) was previously used as a landfill. Peat deposits are present within the underlying alluvium. Nine gas monitoring wells were installed and a programme of gas monitoring for the presence of methane, carbon dioxide and oxygen was completed

In-situ gas monitoring results were also obtained from a previous investigation completed by White Young Green (WYG). The Terra Firma and WYG results for the site are summarised in **Table 2.4** below.

Table 2.4 In-situ Gas Monitoring Results			
Monitoring Point	Max CH4 (%)	Max CO2 (%)	Max Flow Rate
White Young Green			
BH409	0.0	1.9	0.3
BH507	12.8	2.3	2.6
BH508	80.6	20.5	3.8
BH516	0.0	0.5	0.5
BH519	43.8	7.6	0.3
BH529	0.0	3.1	0.0
BH530	0.1	5.8	0.2
Terra Firma			
BH1	0.3	12.9	0.0
BH2	6.0	22.0	0.1
BH3	57.9	6.4	0.0
BH4	0.3	0.2	0.1
BH5	0.3	3.7	0.1
BH6	0.3	7.1	0.0
WS1	0.4	12.6	0.4
WS2	1.1	8.9	0.0
WS3	0.5	5.0	0.0

It is also noted that WYG recorded a maximum flow rate of 7.4l/hour on land immediately north of the site.

The in-situ gas monitoring has proven that methane and carbon dioxide gas are being released from the peat beneath the site. There is a risk of these gases entering and accumulating in all new buildings constructed on site.

CIRIA Report C665 can be used to assess the results.

Using the maximum recorded methane concentration of 80.6% and the maximum recorded flow rate of 7.4/hr, a gas screening value (GSV) of 5.96/hr is calculated, as follows:

$$(80.6/100) \times 7.4 = 5.96/\text{hr}$$

When this result is compared with Table 8.5 of CIRIA report C665, the site is classified as 'gas characteristic situation 3-4'.

2.6 Human Health and Environmental Risk Assessment

2.6.1 Human Health

It was concluded that future site users are potentially at risk from contamination in site soils through the following pathways:

- *Dermal contact with soil and soil dust*
- *Ingestion of soil and soil dust*
- *Inhalation of soil dust*
- *Consumption of site grown vegetables/fruit*
- *Ingestion of groundwater*
- *Inhalation of asbestos fibres*

The site is currently deemed to be at risk from flooding from the adjacent River Usk. As part of a flood prevention scheme the site is to be prior to development. This will be achieved by the importation of suitable fill materials.

The fill layer will effectively form a barrier between the made ground on site and site end users, acting to sever the contamination to receptor pathway. The engineered fill is discussed in **Section 3.2**.

No existing soils on site are intended to be disturbed. If any such excavations are to be undertaken at the location of TP7 then appropriate measures should be made for monitoring for airborne asbestos fibres and management of any materials to be removed from site. This is to ensure no adverse human health risks are created.

All garden and landscaped areas will be finished with clean imported subsoil and subsoil. This stage of the development will be fulfilled by the developer. Please refer to **Section 3.3**.

- *Inhalation of radon gas*
- *Inhalation of ground gas/landfill gas*
- *Inhalation of vapours*

Basic radon protection measures should be incorporated into all new buildings on site.

The radon/gas barrier should also be effective as a barrier to PCB vapours.

Gas protection measures are to be installed in the new development. As a minimum the following protection measures will be implemented:

- A 2000 gauge DPM/reinforced gas membrane
- Passive under-floor venting
- All joints taped and sealed

This stage of the development will be fulfilled by the developer

Gas protection measures are discussed in greater detail in **Section 3.4**.

2.6.1 Human Health (Continued)

- *Permeation of drinking water pipes*

Prior to the placement of water supply pipes an assessment should be made, by the water provider, of soil along the route of the pipe with reference made to the material selection criteria quoted in UKWIR Report Ref No 10/WM/03/21 'Guidance for the Selection of Water Supply Pipes to be used in Brownfield Sites'.

This stage of the development will be fulfilled by the developer.

2.6.2 Aquatic Environment

The River Usk flows along the western edge of the site and is considered as the most vulnerable environmental receptor.

The petroleum hydrocarbons identified during the first groundwater monitoring round were attributed to contamination that occurred from the drilling process. Following purging of the boreholes on the second round of water sampling all hydrocarbons were below guideline values.

The hydrocarbons noted at the ree were identified up-stream but not down-stream and it was concluded that all of the determinants exiting the site and entering the River Usk from the ree were below threshold values.

Two rounds of groundwater testing in March 2014 identified only a single exceedence of zinc, in one location.

Monitoring of groundwater level in boreholes in January 2014 confirmed that there was no tidal influence on groundwater in underlying gravel and no hydraulic continuity between groundwater and the River Usk.

The River Usk and hydrological environment are not therefore considered to be at risk.

Please refer to **Section 3.7**.

SECTION 3 Proposed Site Remediation

3.1 Remediation Summary

Based on the site investigative works the following is proposed to protect construction workers and future site end users:

1. Cover of site with up to 2.75m of imported fill (intended to raise site above flood plain).

Riversee Limited is to raise the site to a level of 8.8m AOD before passing the site on to the developer. This will be an increase in level by up to 1.6m.

The developer will further raise the site to a level of 9.95m AOD.

2. Capping with 600mm of clean soil (subsoil and topsoil) in garden and landscaped areas.
3. Current minimum requirements is the installation of a 2000 gauge membrane suitable for protection against ground gas, radon gas and PCB vapours in all new buildings. Passive under-floor venting and taping and sealing of all joints will also be required. Dependant on further on-site flux box gas monitoring (see Section 3.4) more robust gas protection measures may be required.
4. Sampling and analysis of groundwater during and following initial fill works.
5. New water supply pipes to be chosen in accordance with UKWIR Report Ref No 10/WM/03/21 'Guidance for the Selection of Water Supply Pipes to be used in Brownfield Sites'.

Any unexpected ground conditions or contamination identified during site development should be inspected and appropriately investigated by a geo-environmental engineer. This may include suspension of site works until the details and severity of any contamination has been established and the potential risks to human health assessed.

3.2 Importation of Fill for Engineering Purposes

Fill importation will need to take into account the location of the site adjacent to the River Usk and within a SSSI. It is essential that any material brought on to site will not have an impact on the underlying ground and the river, and that it will not present an unacceptable risk to the human health of future site end users.

Appropriate permits will therefore need to be in place.

In order to assess the suitability of intended fill soils they will need to undergo appropriate screening, prior to being brought on to site.

Testing needs to be carried out in accordance with 'Requirements for the Chemical Testing of Imported Materials for Various End Uses and Validation of Cover Systems'.

All fill should as a minimum be screened for the substances listed in **Table 3.1** on the following page.

3.2 Importation of Fill for Engineering Purposes (Continued)

The Human Health Guidelines are based on CLEA Guidelines published by the Environment Agency, or in their absence Generic Assessment Criteria (GAC) for a residential setting, published by the Chartered Institute of Environmental Health (CIEH), or in the case of lead, the ATRISK guideline provided by Atkins.

Table 3.1 Soil Determinants and Guideline Values Imported Engineered Fill Material				
Determinant	Comparable Guideline Value (mg/kg)			Source
Arsenic	32			CLEA
Beryllium	51			CIEH
Boron	291			CIEH
Cadmium	10			CLEA
Chromium III	627			CIEH
Chromium VI	4.3			CIEH
Copper	2330			CIEH
Lead	383			ATRISK
Mercury	170			CLEA
Manganese	-			-
Molybdenum	-			-
Nickel	130			CLEA
Selenium	350			CLEA
Zinc	3750			CIEH
Cyanide	8			CLEA
Antimony	-			-
Phenol	420			CLEA
pH (acidity)	-			-
Asbestos	Non detectable			-
	≤ 1% SOM	≤ 2.5% SOM	≤ 6% SOM	
Naphthalene	1.5	3.7	8.7	CIEH
Acenaphthylene	170	400	850	CIEH
Acenaphthene	210	480	1000	CIEH
Fluorene	160	380	780	CIEH
Phenanthrene	92	200	380	CIEH
Anthracene	2300	4900	9200	CIEH
Fluoranthene	260	460	670	CIEH
Pyrene	560	1000	1600	CIEH
Benzo(a)anthracene	3.1	4.7	5.9	CIEH
Chrysene	6.0	8	9.3	CIEH
Benzo(b)fluoranthene	5.6	6.5	7.0	CIEH
Benzo(k)fluoranthene	8.5	9.6	10	CIEH
Benzo(a)pyrene	0.83	0.94	1.0	CIEH
Dibenzo(ah)anthracene	0.76	0.86	0.9	CIEH
Benzo(ghi)perylene	44	46	47	CIEH
Indeno(123cd)pyrene	3.2	3.9	4.2	CIEH

3.2 Importation of Fill for Engineering Purposes (Continued)

Table 3.1 (Continued)				
Soil Determinants and Guideline Values				
Imported Engineered Fill Material				
Determinant	Comparable Guideline Value (mg/kg)			Source
Petroleum Hydrocarbons				
	≤ 1% SOM	≤ 2.5% SOM	≤ 6% SOM	
Aliphatic EC >5-6	30	55	110	CIEH
Aliphatic EC >6-8	73	160	370	CIEH
Aliphatic EC >8-10	19	46	110	CIEH
Aliphatic EC >10-12	93	230	540	CIEH
Aliphatic EC >12-16	740	1700	3000	CIEH
Aliphatic EC >16-35	45000	64000	76000	CIEH
Aliphatic EC >35-44	45000	64000	76000	CIEH
Aromatic EC >5-7 (benzene)	-	-	0.33	CLEA CIEH
Aromatic EC >7-8 (toluene)	65	130	-	CLEA CIEH
Aromatic EC >8-10	-	-	610	CLEA CIEH
Aromatic EC >10-12	120	270	-	CIEH
Aromatic EC >12-16	27	65	151	CIEH
Aromatic EC >16-21	69	160	346	CIEH
Aromatic EC >21-35	140	310	593	CIEH
Aromatic EC >35-44	250	480	770	CIEH
	890	1100	1230	CIEH
	890	1100	1230	CIEH

Table Notes

- CLEA - Soil Guideline Values for residential development
- CIEH - Generic Assessment Criteria for a residential setting
- ATRISK – Generic assessment criteria (without plant uptake) developed by Atkins
- SOM - Soil Organic Matter

The tables list a general test suite of general determinants for soils although additional determinants may be recommended for situations where the donor site(s) is known to have a former industrial land use.

3.2 Importation of Fill for Engineering Purposes (Continued)

In respect to groundwater risk it is proposed that all materials will undergo 2:1 soil leachate analysis **in accordance with BS:EN:12457** for the substances listed in **Table 3.2**. Results should be compared to the Environment Agency Guidelines.

Table 3.2 Leachate Assessment Criteria		
Determinant	Comparable Threshold (mg/l)	Source
Arsenic	0.025	WFD
Cadmium	0.0002	WFD
Chromium *	0.0006	WFD
Copper	0.005	WFD
Lead	0.0072	WFD
Mercury	0.0005	WFD
Nickel	0.02	WFD
Selenium	0.01	WHO
Zinc	0.04	WFD
Cyanide	0.001	WFD
Phenol	0.0077	WFD
Chloride	N/A	-
Fluoride	0.5	DSD
Speciated PAH		
Napthalene	0.0012	WFD
Acenaphthylene	-	-
Acenaphthene	-	-
Fluorene	-	-
Phenanthrene	-	-
Anthracene	0.0001	WFD
Fluoranthene	0.0001	WFD
Pyrene	-	-
Benzo(a)anthracene	-	-
Chrysene	-	-
Benzo(b)fluoranthene	0.00003	WFD
Benzo(k)fluoranthene	0.00003	WFD
Benzo(a)pyrene	0.00005	WFD
Dibenzo(ah)anthracene	-	-
Benzo(ghi)perylene	0.000002	WFD
Indeno(123cd)pyrene	0.00002	WFD

3.2 Importation of Fill for Engineering Purposes (Continued)

Table 3.2 (Continued) Leachate Assessment Criteria		
Determinant	Comparable Threshold (mg/l)	Source
Petroleum Hydrocarbons		
Aliphatic EC >5-6	-	-
Aliphatic EC >6-8	-	-
Aliphatic EC >8-10	-	-
Aliphatic EC >10-12	-	-
Aliphatic EC >12-16	-	-
Aliphatic EC >16-35	-	-
Aliphatic EC >35-44	-	-
Aromatic EC >5-7 (benzene)	0.008	WFD
Aromatic EC >7-8 (toluene)	0.04	WFD
Aromatic EC >8-10 (xylene)	0.03	WFD
Aromatic EC >10-12	-	-
Aromatic EC >12-16	-	-
Aromatic EC >16-21	-	-
Aromatic EC >21-35	-	-
Aromatic EC >35-44	-	-

Table Notes

- WFD – Water Framework Directive threshold for coastal and transitional waters/other waters (annual average)
- World Health Organisation threshold for drinking water (in absence of WFD threshold)
- DSD – Dangerous Substances Directive saltwater annual average (in absence of WFD threshold)
- *Threshold for Chromium VI
- - No guideline available

The number of representative samples of the fill that will require analysis will depend on the volume of soil and number of soil sources.

A significant volume of soil will be required to attain the desired levels.

It is proposed that for each 250m³ (or part of) that 1 representative sample be taken for screening, per source. This has been agreed with Newport City Council.

As suggested by Newport City Council Environmental Protection, the sampling frequency may be reduced if fill is sourced from a quarry or quarried supply if accompanied with recent and representative analysis which includes heavy metals.

3.2.1 Fill Materials - Riversee Limited

Riversee Limited will be increasing the level of the site to 8.8m AOD before passing the site on to the developer. This will be an increase in level by up to 1.6m.

Riversee Limited currently retain a stockpile of soil on land adjacent to the site, which measures 22,000m³ in volume. This stockpile is intended for use, in conjunction with imported quarry stone.

The stockpile is derived from a number of indistinguishable sources, comprising 'recovered' soils from previous construction sites in the local area. It has therefore been treated as a singular source.

The stockpile has been partially sampled and tested.

All substances (as per **Table 3.1**) were confirmed to be present at levels below their respective threshold levels.

However, asbestos was identified in a 17 of the 36 samples. With the exception of one sample, the fibre content of all samples was found to be below the laboratory detection limit of 0.001%. This would classify the soils as non-hazardous waste with respect to asbestos.

One occurrence of asbestos containing cement was recorded.

Riversee Limited is currently in discussion with the NRW with the aim of obtaining a bespoke permit allowing the re-use of this material provided adequate control and protection is in place to prevent any impact by asbestos on the surrounding environment, and to ensure that there will be no risk to the human health of site workers and neighbouring site users.

It is anticipated that the permit will outline how the asbestos containing soils will be managed by a combination of appropriate health and safety measures and by the placement of an overlying 300mm clean capping layer above the stockpile sourced fill (from 8.5m – 8.8m AOD), including on all embankments.

Reinforced earth embankments will be utilised to retain the filling works, along with the existing flood defence embankment along the front of the site. Please refer to the attached fill works drawing in **Annex A**.

The site will be further filled with an additional layer of approximately 1m during the residential development operation.

The 300mm capping layer should chemically strictly adhere to **Table 3.1**.

Leachate analysis upon the stockpile soils will be performed in the next two weeks and the results circulated as an update to the report.

Similarly, the results of all tests will be made available for review and approval by Newport City Council and the NRW prior to importation, in line with Condition 20 of the Planning Application.

3.3 Importation of Soils for Gardens and Landscaped Areas

Following construction of the houses on site, the developer will complete all garden and landscaped areas with both imported subsoil and topsoil, attaining a total minimum thickness of 600mm.

For all imported soils appropriate certification should be provided by the supplier as well as details of the soil source.

All imported material should be chemically screened to ensure its suitability for use in accordance with the Welsh Land Contamination Working Group 'Requirements for the Chemical Testing of Imported Materials for Various End Uses and Validation of Cover Systems'.

Ideally imported soils should be stockpiled upon site for sampling. Any stockpiled soils should not be dispersed on site until test results have been received and soil suitability confirmed.

Typically, per source, 4 representative samples should be screened for a volume between 20m³ and 250m³. For volumes exceeding 250m³, 4 samples per 250m³ should be analysed.

Should the imported soils already have been put down in garden and soft landscaped areas before sampling the number of samples required should be calculated according to the volume imported.

Once in place validation of the 600mm thickness will be required. This should comprise the hand excavation of a trial hole in 1 in 3 gardens and photographic evidence documenting measurement to the full depth.

Test results should be compared with residential Soil Guideline Values (SGVs) sourced from The Environment Agency Contaminated Land Exposure Assessment (CLEA). Where SGV values are not available reference should be made to Generic Assessment Criteria (GAC) for a residential setting provided by Land Quality Management Limited and the Chartered Institute of Environmental Health (CIEH), or in the case of lead, the ATRISK guideline provided by Atkins.

3.3 Importation of Soils for Gardens and Landscaped Areas (Continued)

The required testing is detailed in **Table 3.3** below.

Table 3.3 Soil Determinants and Guideline Values Imported Soils				
Determinant	Comparable Guideline Value (mg/kg)			Source
Arsenic	32			CLEA
Boron	291			CIEH
Cadmium	10			CLEA
Chromium III	627			CIEH
Chromium VI	4.3			CIEH
Copper	2330			CIEH
Lead	276			ATRISK
Mercury	170			CLEA
Nickel	130			CLEA
Selenium	350			CLEA
Zinc	3750			CIEH
Cyanide	8			CLEA
Phenol	420			CLEA
pH (acidity)	-			-
Asbestos	Non detectable			-
Speciated PAH				
Napthalene	1.5	3.7	8.7	CIEH
Acenaphthylene	170	400	850	CIEH
Acenaphthene	210	480	1000	CIEH
Fluorene	160	380	780	CIEH
Phenanthrene	92	200	380	CIEH
Anthracene	2300	4900	9200	CIEH
Fluoranthene	260	460	670	CIEH
Pyrene	560	1000	1600	CIEH
Benzo(a)anthracene	3.1	4.7	5.9	CIEH
Chrysene	6.0	8	9.3	CIEH
Benzo(b)fluoranthene	5.6	6.5	7.0	CIEH
Benzo(k)fluoranthene	8.5	9.6	10	CIEH
Benzo(a)pyrene	0.83	0.94	1.0	CIEH
Dibenzo(ah)anthracene	0.76	0.86	0.9	CIEH
Benzo(ghi)perylene	44	46	47	CIEH
Indeno(123cd)pyrene	3.2	3.9	4.2	CIEH

Table Notes

- CLEA - Soil Guideline Values for a residential development
- CIEH - Generic Assessment Criteria for a residential setting, developed as Land Quality Management by the Chartered Institute of Environmental Health
- ATRISK – Generic assessment criteria (with plant uptake) developed by Atkins
- SOM – Soil Organic Matter

3.4 Gas and Vapour Protection

The site has been classified as 'gas characteristic situation 3-4' in accordance with Table 8.5 of CIRIA Report C665.

The action of piling through underlying peat deposits will potentially open up preferential gas pathways, but the alluvial deposits between the peat and made ground can be expected to settle and seal around the piles and drains considerably minimising this risk.

Taking the above into consideration, gas protection measures in line with 'gas characteristic 2' may prove adequate to prevent the risk from ground gas to future site residents.

Table 8.6 of the CIRIA report confirms that for gas characteristic 2 sites, the following precautions are required:

- A 2000 gauge DPM/reinforced gas membrane
- Passive under-floor venting
- All joints taped and sealed

As a minimum these protection measures will be implemented. However, further on-site gas monitoring from already installed wells and from flux boxes is to be undertaken during development to confirm that this level of protection will be suitable.

It is proposed that following placement of the fill, flux boxes will be placed across the site and monitored on a weekly basis for a period of 3 months.

Further flux box testing should be carried out once piling has commenced. The frequency and sampling locations will be considered once the piling schedule has been determined.

Should further monitoring identify concentrations of methane and/or carbon dioxide and flow rates beyond 'gas characteristic 2' criteria then more robust protection measures will be necessary.

In accordance with Table 8.6 of the CIRIA report, potential further protection measures could include:

- Proprietary gas resistant membrane
- Positively pressurised underfloor sub-space
- In-ground venting and venting wells

The results of all additional monitoring and consequent gas protection recommendations will be presented to Newport City Council for review.

The developer will also provide details on proposed validation testing of the gas mitigation measures.

All test certification will be issued to Newport City Council prior to occupancy.

The radon/gas barrier should also be effective as a barrier to PCB vapours.

3.5 Asbestos Management and Monitoring – In-situ Soils

If excavations are to be undertaken at the location of TP7 prior to site fill works then appropriate measures should be made to ensure there are no risks to construction workers and neighbouring site occupants/users.

Monitoring for airborne asbestos fibres would be required, including along the boundary of the site. A strategy should also be put in place to deal with any fibres, should they be detected.

Any materials to be removed from site should be appropriately managed to mitigate all potential risks.

If required, a strategy for monitoring asbestos and removing materials should be drawn up and approved by Newport City Council Environmental Protection prior to site works.

The details and data from any monitoring etc should be compiled and reported to Newport City Council Environmental Protection.

3.6 Potable Water Supply

Details of the proposed drinking water supply pipes should be supplied by the developer to Newport City Council for approval prior to development.

The UKWIR Report Ref No 10/WM/03/21 'Guidance for the Selection of Water Supply Pipes to be used in Brownfield Sites' should be consulted.

3.7 River Usk and Groundwater

Groundwater and ree water testing to date has not identified a risk to the River Usk. No hydraulic continuity between the river and groundwater has been identified.

In order to increase confidence that groundwater will not present a risk to the aquatic environment further assessment is proposed. Prior to fill of the site by Riversee Limited six new water monitoring wells will be installed across the development site. The response zone of these wells will be the deep groundwater.

During and following Riversee Limited earthworks the wells will be sampled. In total three water sampling rounds will be undertaken, on a monthly basis. The drainage ree will also be sampled at these times.

Water samples will be analysed for a standard suite of metals and inorganics, speciated PAH and petroleum hydrocarbons.

The results from this monitoring will be assessed and reported to both Newport City Council and National Resources Wales in due course.

Should the results highlight a concern with regard to a change in groundwater quality further sampling or remedial measures will be agreed with Newport City Council and National Resources Wales as appropriate.

SECTION 2 Validation Report

All remedial works should be documented and details compiled in the form of a Validation Report.

The validation will be reported in two stages.

A Validation Report will be compiled for Riversee Limited following completion of the initial fill of the site once all associated monitoring has concluded.

The Validation Report should include, but not limited to, the following:

1. Details of source of imported material including imported stone/aggregate
2. A record of the number of soil sources, their origin, and their respective volumes
3. Chemical certificates for fill imported for engineering purposes
4. Data from any asbestos monitoring carried out
5. Results from groundwater monitoring carried out during and immediately following the earthworks.
6. Records of any materials removed from site
7. Records of the flux box testing

The Developer will be responsible for commissioning a second Validation Report once the development has been completed.

The Validation Reports should include, but not limited to, the following:

1. Details of source of imported material including imported stone/aggregate
2. A record of the number of soil sources, their origin, and their respective volumes
3. Chemical certificates for fill imported for engineering purposes
4. Chemical certificate for imported garden soils where available from the provider
5. Chemical tests results for garden and landscaped soils once tested on site
6. Validation of the 600mm capping thickness in garden and landscaped areas including photographs
7. Details of the gas protection measures employed, including photos, test results and certificates.
8. Records of any materials removed from site

Validation reports should be submitted to Newport City Council and National Resources Wales for review.

Annex A
Drawing Detailing Area to be Filled
to 8.8m AOD by Riversee Limited



AREA LOCALLY RAMMED UP FROM EXISTING LAINE TO FORM SITE ACCESS HAUL ROAD

SECTION A
DEFINES AREA OF REINFORCED EMBANKMENT @ 40° RAISING EXISTING LEVELS UP TO +8.800

SECTION B
DEFINES AREA OF FILL UP AGAINST EXISTING RAISING LEVELS UP TO +8.800

SECTION C
DEFINES FILL LEVEL TO +8.800

SECTION D
DEFINES EXISTING BANK LEADING UP TO TOP PATH + 9.50 APPROX LEVEL

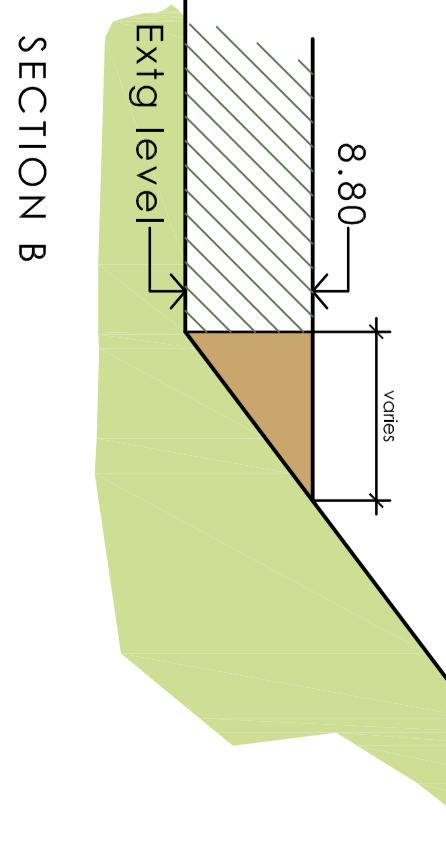
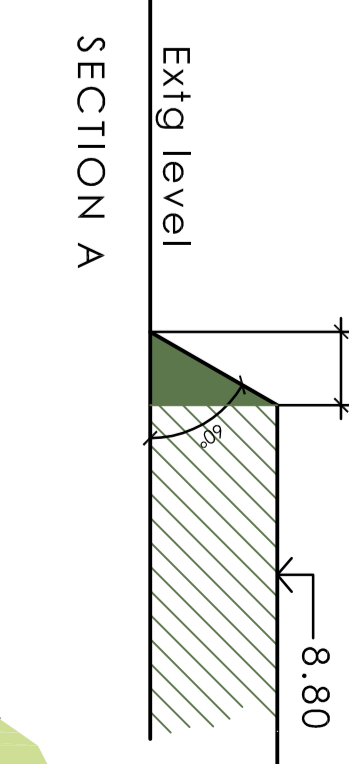

LIMIT OF RETAINING CONCRETE RETAINING WALLS.

Drawing Purpose
CONSTRUCTION

Client	Drawing No	Scale	Revision	Revisions
Riverson	LT1420.90.01	1@200@A0		
Job Title	Drawing Title	Date	Checked	
Herbert Road	Fill Level drawing	Feb 15		



Do not scale from this drawing. The users of this drawing shall check all dimensions & report all errors and omissions to LeTrucco Design. This drawing is copyright. It must not be copied, used or disclosed to third parties without prior permission of LeTrucco Design.