

Device Installation Operation and Method Statement (DIOMS): Floating Tidal Energy Converter

Contents

Introduction	1
Device design, operation and test aims	1
Consideration of blade clearance at Warrior Way	4
Consideration Marine Mammals collision risk/entanglement protocols	4
Key Locations	4
Overview of Method Statement and PEMMP Measures.....	6

Introduction

This document has been drafted to comply with Marine Licence ORML1957v2 Condition 3.30:

“The Licence Holder must submit a Device-specific Installation and Operation Method Statement (DIOMS) to the Licensing Authority for written approval. The DIOMS must detail how all the Project EMMP requirements (condition 3.27) have been incorporated and consider:

- *Review of device design (for minimisation of ingress for WEC devices, minimum blade clearance at Warrior Way and maximum dimension devices (triggering further monitoring requirements) at East Pickard Bay)*
- *Marine Mammals collision risk/entanglement protocols*
- *Decommissioning*

Works must be carried out in line with the approved DIOMS. Any proposed changes to the DIOMS must be submitted to and agreed in writing by the Licensing Authority prior to any changes being enacted.”

Device design, operation and test aims **Updated Text**

META would like to deploy the updated device described below at the META Warrior Way site for 1 month from 10th November 2025 to the 12th December 2025.

The updated device now comprises a 1.3m diameter turbine designed by Gul Corp and mounted on the existing test barge provided by Rudders Boatyard (Figures 1 – 3). There is no power take off and the performance of the turbine will be measured with a torque sensor on the rotor. The blade will be fully submerged at all times with a minimum clearance of 2m from the sea surface.

For reference the device previously had a 3m diameter turbine with electrical power take off designed by C-GEN Engineering, so this updated turbine from Gul Corp is a reduction in size and complexity.



Figure 1 Test barge (10m x 6m).

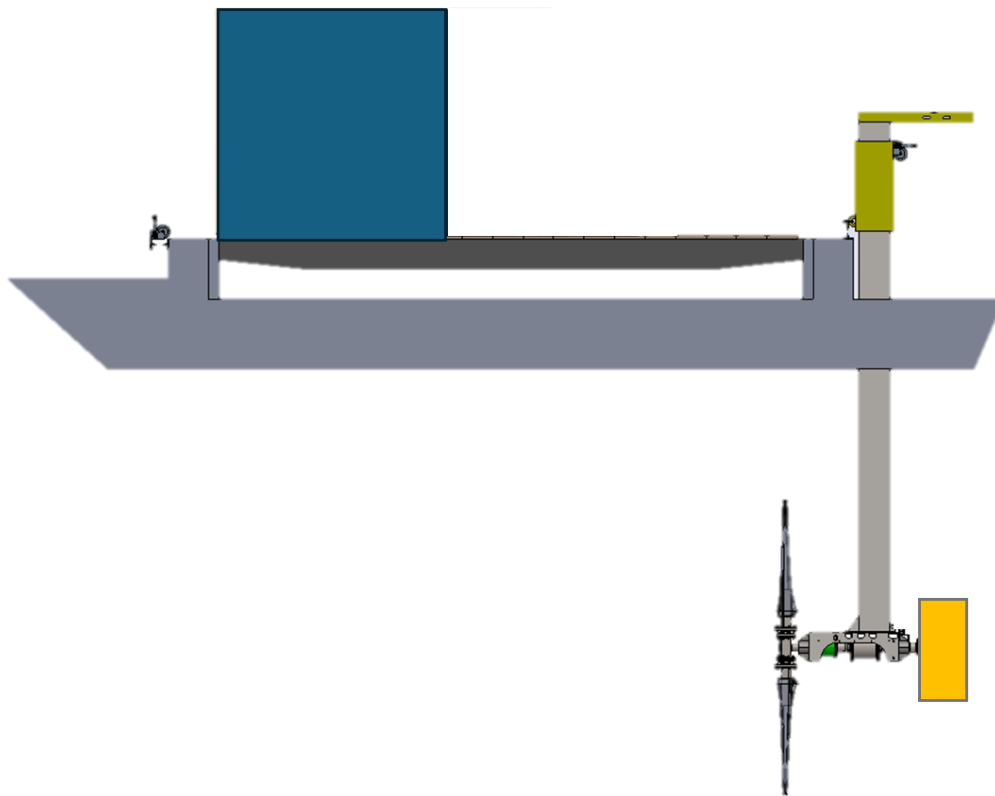

Figure 2 Device in operational position (not to scale)

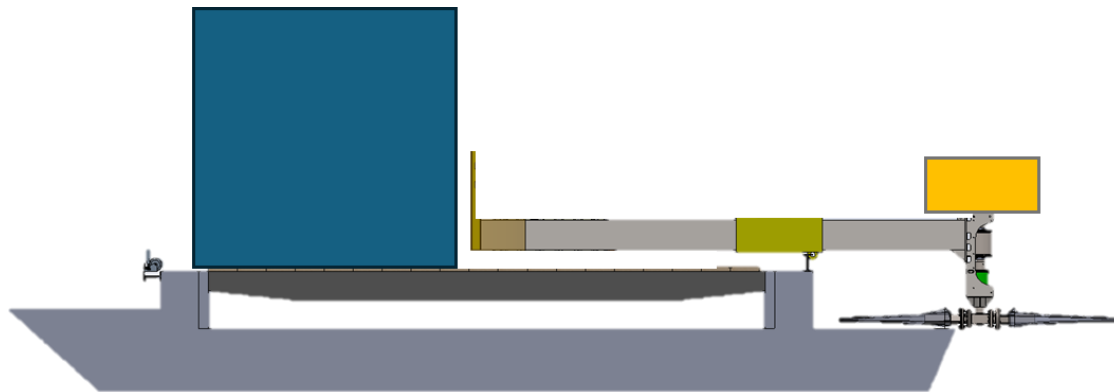

Figure 3 Device in towing position (not to scale)

The floating platform is moored in position with a swinging mooring using two 2.5tn gravity anchors 10m apart perpendicular to the flow, each with ground chain and octoplait rope risers, attached to a large swivel and hard-shell buoy, to which the floating platform is then tethered to using a bridle. This mooring arrangement will allow the floating platform to align with the flow on both the flood and ebb tide. The drawing below illustrates the full system (Figure 4). This mooring system proved successful to moor the same test barge in this location at Warrior Way in February 2025 to support the Porpoise Power test programme.

Deployment and Decommissioning of the device and anchors will be performed by one vessel with appropriately sized lifting capability. Anchors and mooring lines will be deployed first, then the device will then be towed to site and connected to the pre-laid moorings. Decommissioning can then be performed in the reverse order.

1. Gravity anchor
2. Chain
3. Mooring Line
4. Swivel connector – swinging mooring
5. Test barge with turbine attached
6. Tidal turbine and generator (enclosed yellow box)

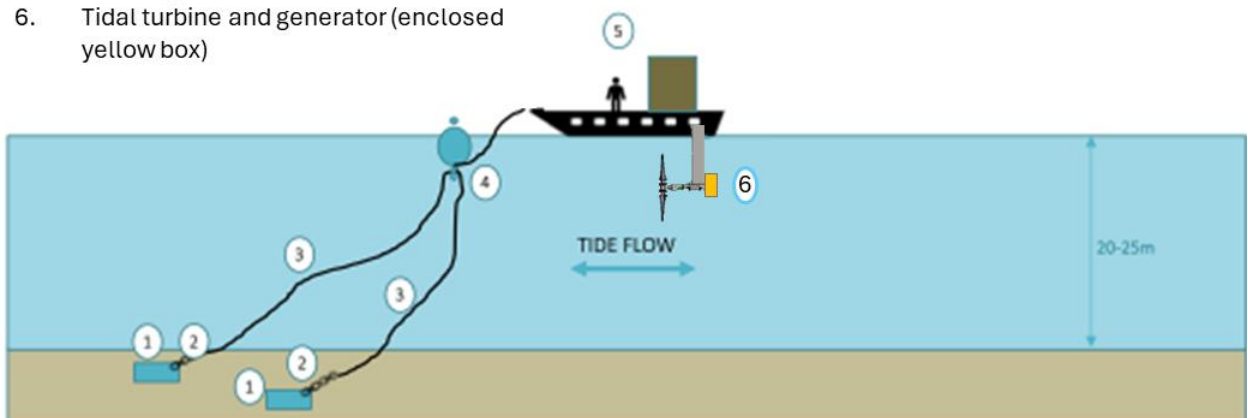

Figure 4 Illustration of full system not to scale.

Consideration of blade clearance at Warrior Way

With reference to considerations required by ORML1957v2 condition 3.30 the tidal energy convertor blade has been designed to be submerged at all times with a minimum clearance of 2m from the sea surface to mitigate any risk to local diving birds i.e. Little Grebe.

Consideration Marine Mammals collision risk/entanglement protocols

With reference to considerations required by ORML1957v2 condition 3.30 best practice measures will be undertaken by vessel operators in the presence of marine mammals, following the published guidelines that are available from the [Pembrokeshire Marine Code](#). Collision risk and entanglement have been assessed as negligible minor and minor adverse respectively in the META Environmental Impact Assessment (based on the maximum scenario which this specific device is notably less than). This is not significant in EIA terms, therefore specific collision risk and entanglement protocols have not been developed. In the very unlikely circumstance, an incident of this nature occurs META PEMP Annex 9 Environmental Incident Reporting procedure will be followed.

Key Locations

The device and moorings are to be located at the following co-ordinates:

Table 1 Device and mooring positions

	Latitude:	Longitude:
Device mooring position	51° 42.222' N	4° 55.61' W

The device will be deployed on a swinging mooring therefore the device will move upstream and downstream of the mooring depending on whether the tide is coming in or out. This mooring design has been chosen so the device always aligns with the current direction and so it can operate in both an incoming and outgoing tide.

For the proposed swinging mooring arrangement, the maximum swing radius from the central mooring position (51° 42.222' N 4° 55.61' W) to the end of the device will be 43m (Figure 4). This is the worst-case scenario for a LWS (Low Water Spring) when there is the most slack in the mooring lines. The device will only be swinging during slack water as the tide turns. Once the tide turns the device will find a settled position either upstream or downstream of the mooring depending which way the tide is flowing. The two mooring blocks will be positioned around 10m apart perpendicular to the tide to minimise lateral movement in relation to the tidal flow direction so the swing radius across the channel will actually be less than the worst-case scenario.

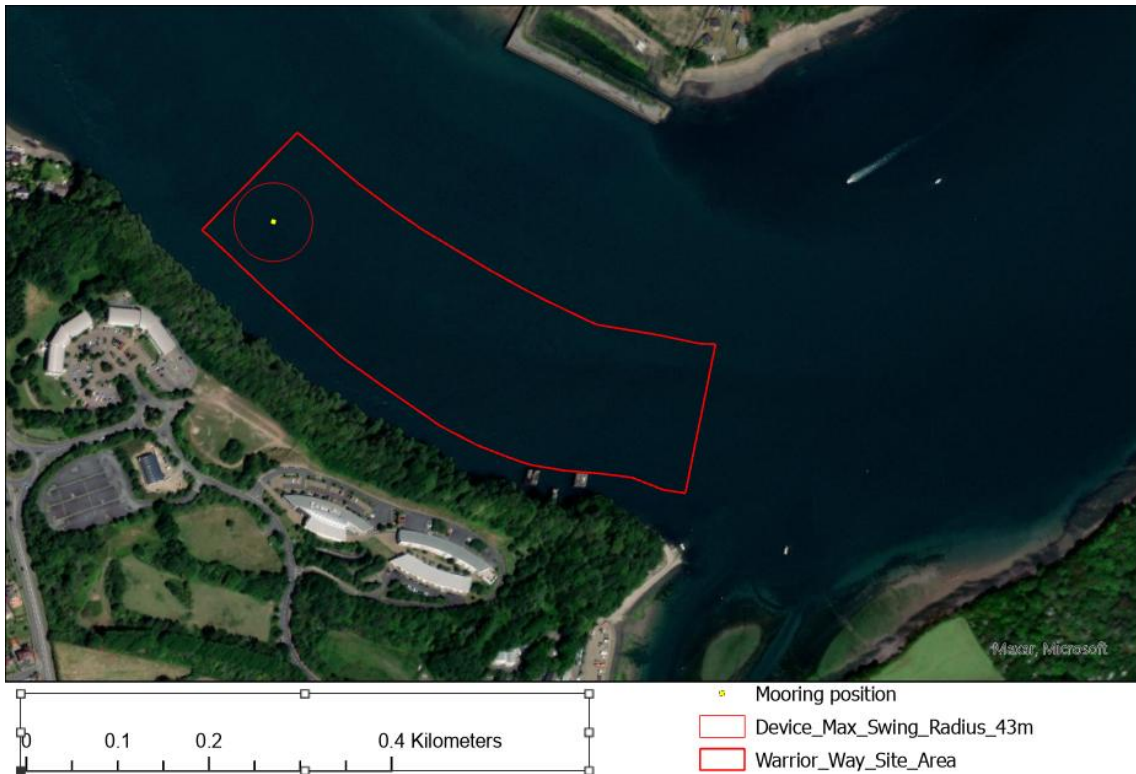

Figure 5 Device position and worst case scenario (LWS) swing radius of the swinging mooring.

Rudders Boatyard will be the vessel contractor. The chart below shows the tow route that will be taken from where the device is launched at Rudders Boatyard to the mooring location (Figure 5).

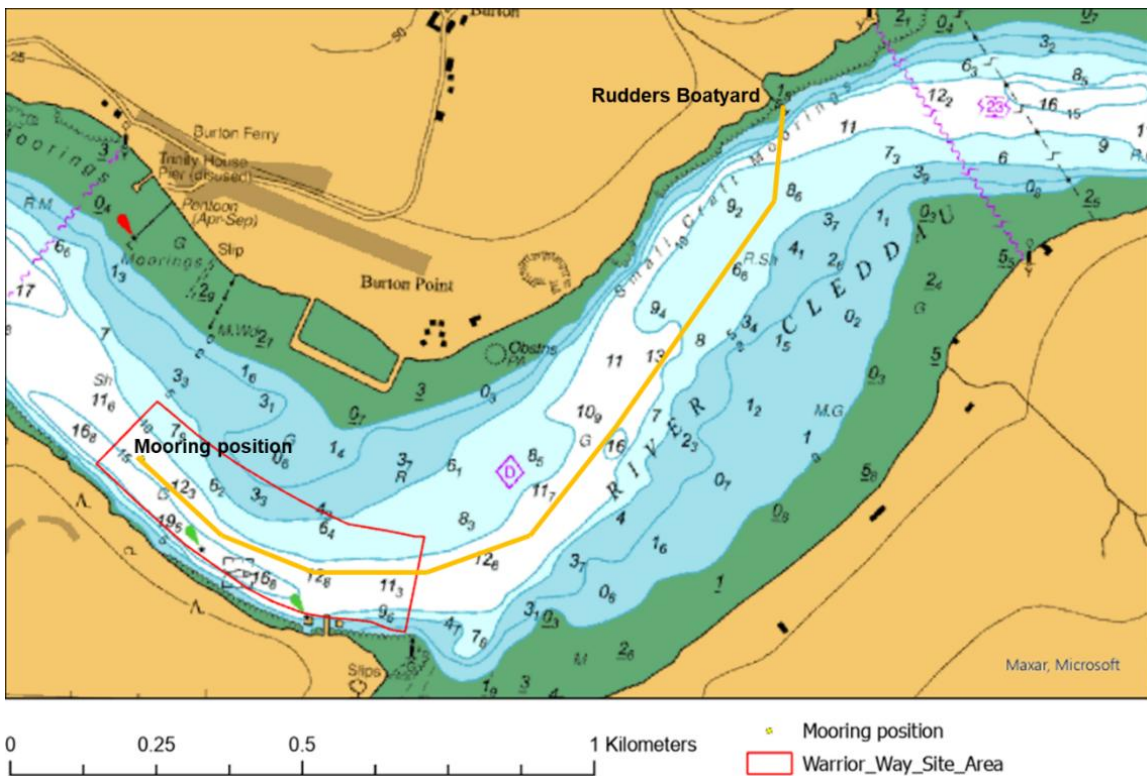

Figure 6 Tow route between the mooring location and the vessel contractor Rudders Boatyard.

Overview of Method Statement and PEMMP Measures

An overview of the method for installation, operations and maintenance and decommissioning is presented in Table 2. In accordance with ORML1957v2 condition 3.30 it references the approved META Project Environmental Mitigation and Monitoring Plan (PEMMP) measures (Table 3) that will be implemented when completing each task.

Table 2 Overview of the method for installation, operations and maintenance and decommissioning

Installation		
Task	Description	Relevant PEMMP measures
1	Vessel contractor to make up and install mooring. Mooring will be micro-sited at locations away from any sensitive habitats / species identified during the Warrior Way Benthic Habitat Mapping by Ocean Ecology (See Device-specific EMP and pre-deployment monitoring report for more details)	<p>Best practice measures to reduce disturbance and collision risk from vessels and to reduce the potential for pollution incidents.</p> <p>Pre-deployment benthic survey to inform micro-siting as detailed in the pre-deployment monitoring plan.</p> <p>META Invasive Non-Native Species Management Plan measures, for example using local vessels and ensuring device components are either new or thoroughly checked and cleaned before they are deployed.</p> <p>Implementation of a META MPCP in order to manage the risk of accidental pollution in the marine environment, including spill kits available on vessel.</p>
2	<p>Assemble Gul Corp and N-Prime tidal energy hardware at Rudders Boatyard.</p> <p>Including removal of C-GEN 3m diameter turbine and attachment of Gul Corp 1.3m diameter turbine</p>	<p>META Invasive Non-Native Species Management Plan measures, for example using local vessels and ensuring device components are either new or thoroughly checked and cleaned before they are deployed.</p> <p>Implementation of a META MPCP in order to manage the risk of accidental pollution in the marine environment, including spill kits available on vessel.</p>
3	Vessel contractor to tow the assembled device to the test site and connect it up to the pre-laid mooring.	Best practice measures to reduce disturbance and collision risk from vessels and to reduce the potential for pollution incidents.

		Implementation of a MPCP in order to manage the risk of accidental pollution in the marine environment
Operations and Maintenance		
Task	Description	Relevant PEMMP measures
1	<p>Personnel to be transported to the device and, onboard the platform, run a series of performance tests on the device.</p> <p>The device will also be able to operate remotely and there will be failsafe processes for monitoring the device and remote shutdown. Any loss of power will also shutdown the system and bring the blades to a halt.</p>	<p>Best practice measures to reduce disturbance and collision risk from vessels and to reduce the potential for pollution incidents.</p> <p>Implementation of a META MPCP in order to manage the risk of accidental pollution in the marine environment, including spill kits available on vessel.</p>
2	<p>During the test programme the vessel contractor may detach the device from the moorings and tow it back to the contractor's dock to conduct maintenance and optimisation tasks that cannot be conducted at sea. Following the completion of the necessary works at the dock the vessel contractor will tow the device back to site and reconnect it to its moorings</p>	<p>Best practice measures to reduce disturbance and collision risk from vessels and to reduce the potential for pollution incidents.</p> <p>Implementation of a META MPCP in order to manage the risk of accidental pollution in the marine environment, including spill kits available on vessel.</p>
Decommissioning		
Task	Description	Relevant PEMMP measures
1	<p>Once testing is complete, the vessel contractor is to detach the device from the moorings and tow it back to the contractor's dock</p>	<p>Best practice measures to reduce disturbance and collision risk from vessels and to reduce the potential for pollution incidents.</p> <p>Implementation of a META MPCP in order to manage the risk of accidental pollution in the marine environment, including spill kits available on vessel.</p>
2	<p>All hardware and equipment are to be removed from the floating platform. Heavy objects are to be crane lifted from the floating platform.</p>	
3	<p>The floating platform is then to be disassembled, and crane lifted from the water by the vessel contractor</p>	

4	The vessel contractor is to lift and remove the moorings from the test site, leaving no equipment on the seabed.	<p>Best practice measures to reduce disturbance and collision risk from vessels and to reduce the potential for pollution incidents.</p> <p>Implementation of a META MPCP in order to manage the risk of accidental pollution in the marine environment, including spill kits available on vessel.</p>
---	--	--

NOTE: all lifting operations are to be performed by the vessel contractor’s qualified personnel using the vessel contractor’s certified lifting equipment.

Table 3 Summary of META Project EMMP measures to be undertaken during Floating Tidal Energy Convertor deployment at Warrior Way

Receptor	Mitigation/ Survey / Monitoring	Description	Mechanism for Implementation
All birds	Mitigation	Best practice measures to reduce disturbance from vessels and to reduce the potential for pollution incidents.	PEMP (Annex 7), Section 4.2.2
All birds	Mitigation	Implementation of a Marine Pollution Contingency Plan (MPCP) in order to manage the risk of accidental pollution in the marine environment	PEMP (Annex 7), Section 4.2.1
Diving birds	Mitigation	A minimum distance of 2 m will be maintained between the tip of operational turbine blades and the sea surface.	PEMP (Annex 7), Section 4.2
All marine mammals, basking shark and otter	Mitigation	Implementation of a MPCP in order to manage the risk of accidental pollution in the marine environment	PEMP (Annex 7), Section 5.2.1
All marine mammals, basking shark and otter	Mitigation	Best practice measures to reduce disturbance and collision risk from vessels	PEMP (Annex 7), Section 5.2.2
All fish and shellfish	Mitigation	Implementation of a MPCP in order to manage the risk of accidental pollution in the marine environment	PEMP (Annex 7), Section 6.2.1
Benthic habitats and species	Mitigation	Invasive Non-Native Species Management Plan	PEMP (Annex 7), Section 7.2.3
Sensitive habitat and species	Mitigation	Micro-siting of devices or components on the seabed	PEMP (Annex 7), Section 7.2.2
Benthic habitats and species	Mitigation	Implementation of a MPCP in order to manage the risk of accidental pollution in the marine environment	PEMP (Annex 7), Section 7.2.1
Archaeological receptors	Mitigation	Micro-siting to avoid impact on marine archaeology receptors	PEMP (Annex 7), Section 8.2