

2020-04-21
EN
0000000470
V.006
3.48.0
5402
93150-002



Wood chip boiler eHACK 180 - 240 kW



Installation





ETA Heiztechnik

Gewerbepark 1

A-4716 Hofkirchen an der Trattnach

Tel: +43 (0) 7734 / 22 88 -0

Fax: +43 (0) 7734 / 22 88 -22

info@eta.co.at

www.eta.co.at

Contents

1	General	5
1.1	Preface	5
1.2	General information	5
1.3	Warranty, guarantee and liability	6
2	Technical data	8
2.1	Energy Labelling	10
3	Regulations, standards and guidelines	12
4	CE-Conformity	13
5	Boiler room	14
6	Safety	15
6.1	General information	15
6.2	Safety devices	15
6.3	Emergency stop switch	17
6.4	Safety devices in the fuel path	18
7	Information for installation	21
7.1	Chimney	21
7.1.1	Planning and layout	21
7.1.2	Renovation	25
7.2	General information	25
7.3	Water hardness	26
7.4	Corrosion	27
7.5	Bleeding	27
7.6	Pressure equalisation	28
7.7	Noise emission	29
8	Buffer storage tank	30
8.1	General information	30
8.2	Hydraulic integration	31
8.3	Connection between multiple buffer storage tanks	34
8.4	Parallel buffer connection	36
8.5	External Tichelmann	38
8.6	Serial buffer connection	40
9	Installation	42
9.1	Placement of the boiler	42
9.2	Mount flue gas connection	42
9.3	Mounting the air valve for flue gas recirculation (optional)	43
9.4	Removing panels	44
9.5	Stoker	44
9.6	Assembling the conveyor	46
9.7	Installing the drive chain	53
9.8	Fuel store	53
9.9	Align boiler horizontally	54
9.10	Ash box	54

9.11	Cables	56
9.12	Bottom insulation	57
9.13	Connecting piping	58
9.14	Filling the heating system	59
9.15	Checks	59
9.16	Network connection	60
10	Electrical connections	62
10.1	Requirements	62
10.2	Overview of circuit boards	64
10.3	Circuit board HA-C5	66
10.4	Circuit board GM-C3	70
11	Concluding activities	73
12	Fuel store	74
12.1	Requirements	74
12.2	Dimensioning	74
12.3	Tilted floor	76
12.4	Pellet operation	76
12.5	Heating value	78
12.6	Technical data	79
13	Dismantling, disposal	81

1 General

1.1 Preface

Dear customer,

Safe and satisfactory operation of the product depends, above all, on correct installation. In this user manual, you can find out all the important installation steps, information and instructions for this product beforehand. Please take the time to look through it.

Warranty and guarantee

You should also read the "Conditions for warranty, guarantee, liability" (see chapter [1.3 "Warranty, guarantee and liability"](#)) carefully. As a rule, a professional heating technician shall satisfy these conditions. Nevertheless, inform the technician of our warranty conditions. All of the requirements we impose are intended to prevent damage that neither you nor we wish to occur.

Training the customer

To avoid errors in operation, please explain to your customer exactly how his new product works and how it should be operated and maintained.

Remote control of the boiler via the internet

The remote control enables you to operate your ETA boiler remotely via your own network (VNC Viewer) or the internet <www.meinETA.at> using a PC, smartphone or tablet, as though you were standing right in front of the ETAtouch control system of your ETA boiler. A LAN cable is required for the connection from the ETAtouch control system to the internet modem.

 Details for the remote control can be found in the manual "Communication platform meinETA". Details for the connection of the LAN cable, see [9.16 "Network connection"](#).

Extended warranty

We grant an extended warranty if the product is commissioned by an authorised partner company or by our own customer service. In this regard, please note the warranty conditions applicable at the time of purchase.

Service agreement

You can ensure the best care for your heating system by taking out a service agreement with one of our certified contractors or our own customer service.

1.2 General information

Copyright

All contents of this document are property of ETA Heiztechnik GmbH and are protected by copyright. Any reproduction, transfer to third parties or use for other purposes is prohibited without written permission from the owner.

Subject to technical changes

We reserve the right to make technical modifications without notice. Printing and typesetting errors or changes of any kind made in the interim are not cause for claims. Individual configurations depicted or described here are only available optionally. In the event of contradictions between individual documents regarding delivery scope, the information in our current price list applies.

Explanation of symbols

 Instructions and information

Layout of safety instructions

SIGNAL WORD!

Type and source of danger

Possible effects

- Measures for avoiding the danger

Types of safety instruction

CAUTION!

On non-compliance with this safety instruction, there is a risk of material damage.

WARNING!

On non-compliance with this safety instruction, there is a risk of physical injury.

DANGER!

On non-compliance with this safety instruction, there is a risk of major physical injury.

1.3 Warranty, guarantee and liability

Requirements

We can only accept liability for the function of our products if they are correctly installed and operated. This is only possible if the conditions below are complied with.

Maximum of 2,000 hours at full load per year

The boiler described in this user manual may only be used for heating and producing hot water, with no more than 2,000 full-load hours annually.

Installation in a dry room

For set-up, a dry room is required. In particular, only condensation dryers may be used as clothes dryers in the same room.

Observe local building and fire safety regulations

Local building and fire safety regulations must be observed.

Suitable fuels

- Wood chips according EN ISO 17225-4:2014, quality classes A1/A2/B1/B2, size P16S-P31S, maximum water content 35% (M35)
- Wood pellets according EN ISO 17225-2:2014, quality class A1, ENplus-A1
- Shavings and swarf briquets according EN ISO 17225-3:2014, quality classes A1/A2/B
- In Germany: fuel classes 4/5a according 1. BImSchV. Use fuel classes 5/6/7/8 only after consultation with company ETA.

 Operation with unsuitable fuels, in particular high-slag pellets from grain waste, for example, or corrosive fuels such as miscanthus fertilised with potassium chloride, is prohibited.

Ensure supply air is free from aggressive substances

The air supplied to the boiler must be free from aggressive substances such as chlorine and fluorine from solvents, cleaning agents, adhesives and propellants, or ammonia from cleaning agents, to prevent corrosion of the boiler and chimney.

Permissible water hardness

Water is the intended heat-transfer medium. For special anti-frost requirements, up to 30% glycol may be added. Softened water is required for the initial fill-

up of the heating system and for refilling after repairs. Addition of hard water should be minimised to limit limescale build-up in the boiler.

 In order to protect the boiler from calcification, the water hardness of the heating water must be taken into account. Observe the indications outlined in ÖNORM H 5195-1. Details can be found in chapter [7.3 "Water hardness"](#).

pH value between 8 and 9

The pH value of water used to fill the heating system must be between 8 and 9.

Use a sufficient number of shut-off valves

Set enough shut-off valves to avoid bleeding large amounts of water during repairs. Any leaks in the system must be repaired at once.

Provide a sufficiently large expansion tank or a pressure maintaining device

To prevent air from being drawn in while the system is cooling, the heating system professional must provide a sufficiently large expansion tank or a pressure maintaining device.

Open expansion tanks must not be used.

Sufficient power

Operation at lower power than the lowest power specified on the type plate is not permitted.

Expanding the control system

Only components provided by us may be used for expanding the control system, unless these are generally available standard devices, such as thermostats.

Regularly perform cleaning and maintenance

Cleaning and maintaining the product is essential. The required steps and intervals are either contained in this documentation or included as a separate document.

Repairs

Repairs are only permitted using spare parts provided by us. The only exceptions are common standardised parts such as electrical fuses or fastening materials, as long as they possess the required features and do not restrict the functionality of the system.

Proper installation

The installing contractor is liable for proper installation according to the corresponding installation instructions and the relevant rules and safety regulations. If you as

customer have installed the heating system partly or entirely without relevant training and in particular without up-to-date practical experience, without having the installation checked by a trained and responsible expert, we exclude defects in our delivery and consequential damages resulting from this cause from our warranty, guarantee and liability.

Repair of defects

For repairs of defects carried out by the customer or by a third party, ETA shall only bear the costs or remain obligated by warranty if this work was approved in writing in advance by the customer service of ETA Heiztechnik GmbH.

No tampering with boiler safety devices

Boiler safety devices such as those mentioned below must not be tampered with: Temperature monitoring and control devices, safety temperature limiters, safety valves and thermal discharge valves.

Potential equalization is needed for the boiler

The boiler must be connected to the potential equalization of the boiler room or the building. Country-specific regulations must be observed.

Surface corrosion

Surface corrosion on the inside of the precipitator is no cause for concern. It does not impair the function. Surface corrosion does not entitle to warranty or guarantee claims.

2 Technical data

Wood chip boiler eHACK 180-240 kW

The boiler can optionally be supplied with the stoker on either the right or the left side. The illustration shows a boiler with the stoker on the left side.

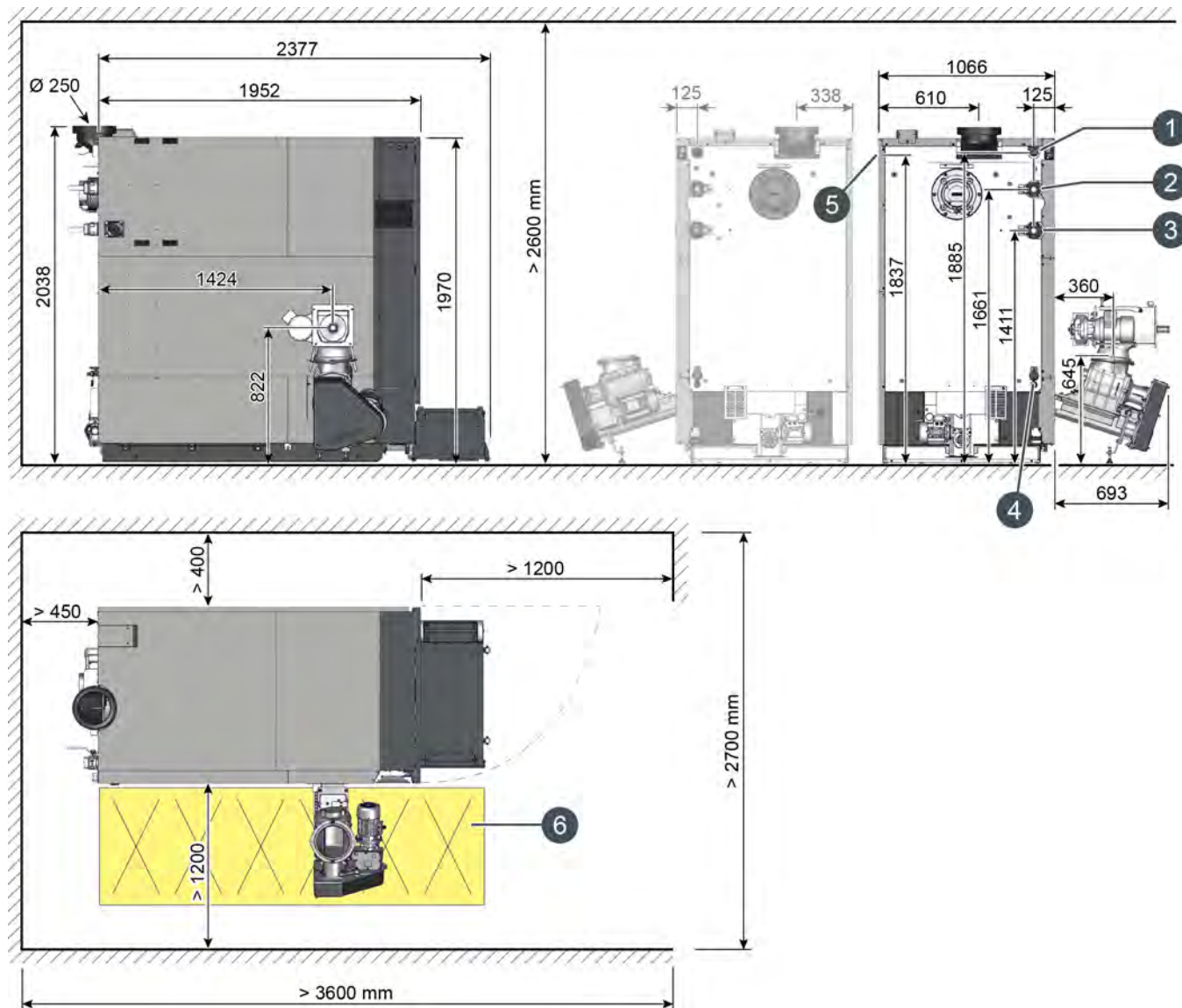

- 1 Connection for safety valve, pressure gauge and bleed valve, R5/4"
- 2 Flow, R2"
- 3 Return, R2"
- 4 Filling and draining valve
- 5 Safety heat exchanger R1/2"
- 6 Maintenance area to be kept clear

 For maintenance on the boiler, an area which is to be kept clear is required on the side of the boiler on which the conveying system (stoker) is mounted. The conveying system may not run through the maintenance area. Also, no expansion tanks or other devices may be installed in this area.

 The flue gas connection on the boiler does not yet give any indication of the required chimney diameter. Information on the required chimney diameter can be found in the installation instructions for the boiler in the Chimney chapter.

Wood chip boiler	Unit	180	200	220	240
Rated capacity, wood chips M25 BD 150 (W25-S160)	kW	53.9 - 179.9	59.9 - 199.9	65.9 - 219.9	71.4 - 238
Rated capacity, pellets	kW	53.9 - 179.9	59.9 - 199.9	65.9 - 219.9	71.9 - 239.9
Efficiency with wood chips at partial/full load	%	96.1 / 94.7	96.6 / 95.2	97.1 / 95.8	97.6 / 96.3
Efficiency with pellets at partial / full load	%	94.3 / 94.4	95 / 94.9	95.7 / 95.3	96.5 / 95.8
Transport dimensions, W x D x H	mm	1076 x 2073 x 1970			
Weight with / without rotary valve stoker	kg	2100 / 1982			
Water content	litres	434			
Water-side pressure drop ($\Delta T = 20$ K)	mWs	0.83	1.03	1.24	1.46
Available residual pump head (at $\Delta T = 20$ K) for buffer operation	mWs	6.5	5.5	4	2.5
	m ³ /h	7.7	8.5	9.4	10.2
Ash box volume	litres	94			
Flue gas mass flow rate, partial / full load	g/s	41 / 120	45 / 130	48 / 139	51 / 148
CO ₂ content in dry exhaust gas partial/full load	%	11.1 / 13.2	11.2 / 13.4	11.2 / 13.7	11.3 / 13.9
Exhaust temperature at partial / full load	°C	~70 / ~130			
Required flue draught	Pa	> 5 Pa			
		A draught limiter is required above 15 Pa			
Carbon monoxide (CO) emissions with wood chips at partial / full load	mg/MJ	26 / 9	23 / 11	20 / 13	17 / 15
	mg/m ³ (13% O ₂)	40 / 14	35 / 17	31 / 21	27 / 23
Carbon monoxide (CO) emissions with pellets at partial/full load	mg/MJ	19 / 2	19 / 2	18 / 2	18 / 2
	mg/m ³ (13% O ₂)	29 / 3	29 / 3	28 / 3	27 / 3
Dust emissions with wood chips at partial/full load	mg/MJ	8 / 9	8 / 9	8 / 9	8 / 8
	mg/m ³ (13% O ₂)	13 / 14	13 / 14	13 / 13	13 / 13
Dust emissions with pellets at partial/full load	mg/MJ	8 / 6	7 / 6	7 / 6	7 / 7
	mg/m ³ (13% O ₂)	11 / 9	11 / 9	11 / 10	11 / 10
Unburned hydrocarbons (CxHy) with wood chips at partial/full load	mg/MJ	1 / 2	1 / 2	1 / 3	1 / 3
	mg/m ³ (13% O ₂)	1 / 2	1 / 3	1 / 4	1 / 4
Unburned hydrocarbons (CxHy) with pellets at partial/full load	mg/MJ	1 / <1	1 / <1	1 / <1	1 / <1
	mg/m ³ (13% O ₂)	1 / <1	1 / <1	1 / <1	1 / <1
Electrical power consumption with wood chips at partial/full load (=values with integrated precipitator)	W	126 / 473 (390 / 743)			
Electrical power consumption with pellets at partial / full load (=values with integrated precipitator)	W	78 / 227 (358 / 487)			
Electrical power consumption in ready mode	W	17			
Maximum permissible operating pressure	bar	3			

Wood chip boiler	Unit	180	200	220	240
Temperature adjustment range	°C	70 – 90			
Maximum permissible operating temperature	°C	95			
Boiler class	5 acc. to EN 303-5:2012				
Suitable fuels	Wood chips ISO 17225-4, P16S-P31S (G30-G50), maximum 35% water content; pellets ISO 17225-2-A1, ENplus-A1				
Electrical connection	400 V AC / 50 Hz / 16 A / 3P+N+PE				
Mode of operation	non-condensing				

Subject to technical changes and errors

2.1 Energy Labelling

Labelling and ecodesign requirements for solid fuel boilers (Lot 15)

The required buffer volume for the boiler can be found in the assembly instructions. All boilers already have the temperature controller integrated, so every product is a "package-system" (boiler with temperature controller).

Wood chip boiler eHACK 180-240 kW

	Unit	Model identification							
		180	180 EP	200	200 EP	220	220 EP	240	240 EP
Item no.		13180 L-D 13180 R-D	13180 -L-D- E 13180 R-D-E	13199 L-D 13199 R-D	13199 -L-D- E 13199 R-D-E	13220 L-D 13220 R-D	13220 -L-D- E 13220 R-D-E	13240 L-D 13240 R-D	13240 -L-D- E 13240 R-D-E
Rated heat output	kW	180		200		220		238	
Fuel supply (manual / automatic)		automatic							
Proportion of the partial load referred to the nominal load (30% / 50%)	%	30							
Temperature controller integrated in the boiler (yes / no)		yes							
Temperature controller class		VIII							
Contribution of the temperature controller to the energy efficiency of the "package-system"	%	5							
Condensing boiler (yes / no)		no							
Combination boiler for hot water and heating (yes / no)		no							
Combined heat and power (yes / no)		no							
Preferred fuel		Wood chips (water content 15-35%)							
Maximum load	kW	179.9		199.9		219.9		238.0	
Partial load	kW	53.9		59.9		65.9		71.4	
Efficiency (in terms of gross calorific value) at maximum load	%	83.2	83.7	83.6	83.5	84.2	84.2	84.6	83.2
Efficiency (in terms of gross calorific value) at partial load	%	84.4	84.8	84.9	85.1	85.3	85.3	85.8	85.8

Wood chip boiler eHACK 180-240 kW

	Unit	Model identification							
		180	180 EP	200	200 EP	220	220 EP	240	240 EP
Electrical power consumption at maximum load	kW	0.473	0.743	0.473	0.743	0.473	0.743	0.473	0.743
Electrical power consumption at partial load	kW	0.126	0.39	0.126	0.39	0.126	0.39	0.126	0.39
Electrical power consumption in ready mode	kW	0.017	0.017	0.017	0.017	0.017	0.017	0.017	0.017
Seasonal space heating energy efficiency	%	81	80	81	80	82	81	82	81
Seasonal space heating emissions - dust	mg/m ³ (10% O ₂)	<40	<40	<40	<40	<40	<40	<40	<40
Seasonal space heating emissions - OGC	mg/m ³ (10% O ₂)	<20	<20	<20	<20	<20	<20	<20	<20
Seasonal space heating emissions - CO	mg/m ³ (10% O ₂)	<500	<500	<500	<500	<500	<500	<500	<500
Seasonal space heating emissions - NOx	mg/m ³ (10% O ₂)	<200	<200	<200	<200	<200	<200	<200	<200
Other suitable fuel									
		Pellets							
Maximum load	kW	179.9		199.9		219.9		239.9	
Partial load	kW	53.9		59.9		65.9		71.9	
Efficiency (in terms of gross calorific value) at maximum load	%	84.3		84.7		85.1		85.6	
Efficiency (in terms of gross calorific value) at partial load	%	84.2		84.8		85.5		86.2	
Electrical power consumption at maximum load	kW	0.227	0.487	0.227	0.487	0.227	0.487	0.227	0.487
Electrical power consumption at partial load	kW	0.078	0.358	0.078	0.358	0.078	0.358	0.078	0.358
Electrical power consumption in ready mode	kW	0.017	0.017	0.017	0.017	0.017	0.017	0.017	0.017
Seasonal space heating energy efficiency	%	81	80	81	81	82	81	83	82
Seasonal space heating emissions - dust	mg/m ³ (10% O ₂)	<40	<40	<40	<40	<40	<40	<40	<40
Seasonal space heating emissions - OGC	mg/m ³ (10% O ₂)	<20	<20	<20	<20	<20	<20	<20	<20
Seasonal space heating emissions - CO	mg/m ³ (10% O ₂)	<500	<500	<500	<500	<500	<500	<500	<500
Seasonal space heating emissions - NOx	mg/m ³ (10% O ₂)	<200	<200	<200	<200	<200	<200	<200	<200



Tab. 2-1: Product data according to EU Regulation 2015/1187 and 2015/1189

3 Regulations, standards and guidelines

Regulations

- Local building regulations
- Industrial and fire safety ordinances and regulations
- State fire regulations
- In Germany, the EnEG (Energy Saving Act) with its enacted EnEV ordinances for energy-saving insulation and energy-saving building technologies
- In Germany, 1.BImSchV, initial ordinance for enforcement of the federal pollution control act for small-scale furnaces
- In Austria, Article 15 a, agreement on protective measures regarding small-scale furnaces
- In Austria, Article 15 a, "Agreement on saving energy"
- In Austria, "TRVB H 118 - Technical Directives for Preventive Fire Safety"
- In Switzerland, VKF/AEAI fire safety regulations 25-03 and 106-03

Standards and guidelines

- ÖNORM H 5195-1 "Prevention of damage due to corrosion and scaling in closed hot-water heating systems".
The permissible water hardness for the heating water can be determined from the table in Section [7.3 "Water hardness"](#).
 The requirements of ÖNORM H 5195-1 apply as minimum requirements for the heating water. If stricter country-specific regulations exist, they are to be heeded.
- VDI 2035, "Prevention of damage due to corrosion and scaling in hot-water heating systems with feed temperatures up to 120 °C".
- EN 12828 "Heating systems in buildings – planning for hot-water heating systems".
The safety temperature limiter (100 °C) is already installed in the boiler. A sufficiently large expansion tank (at least 10% of the system volume), a safety valve (3 bar) and a thermal relief valve must be installed on site. The outlets for the safety valve and the thermal relief valve must be routed to a sewer connection.
 Depending on the national standards, an additional water shortage system or a minimum pressure limiter may be required.
- EN 12831 "Heating systems in buildings - method for calculating standard heating load"
- EN 13384 "Flue systems - thermal and fluid-dynamic calculation methods"
- In Germany, DIN 18160 "Flue systems – planning and design"

- In Austria, ÖNORM H 5170 "Heating systems – construction and fire safety requirements"

Regular emissions measurement for commercial heating plants over 50 kW

Regular emission measurements are prescribed in Austria for all commercial heating systems over 50 kW (see Combustion Plant Ordinance).

4 CE-Conformity

CE declaration of conformity

Manufacturer:	ETA Heiztechnik GmbH 4716 Hofkirchen an der Trattnach, Gewerbepark 1, Austria
Product:	Wood Chip Boiler with fuel conveying system
Types:	ETA eHACK 20 - 240 kW
EU Directives:	
2014/30/EU	Directive relating to electromagnetic compatibility (EMC Directive)
2006/42/EC	Directive on machinery (Machinery Directive)
2014/35/EU	Directive relating to electrical equipment designed for use within certain voltage limits (Low Voltage Directive)
2011/65/EU	Directive on the restriction of the use of certain hazardous substances in electrical and electronic equipment (RoHS 2 guideline)
Applied standards:	
EN-303-5:2012	Heating boilers - Part 5: Heating boilers for solid fuels, manually and automatically stoked, nominal heat output of up to 500 kW - Terminology, requirements, testing and marking
EN ISO 12100:2011	Safety of machinery - General principles for design - risk assessment and risk reduction
EN 60335-1:2012	Safety of household and similar electrical appliances - Part 1: General requirements
EN 60335-2-102:2016	Safety of household and similar electrical appliances - Part 2-102: Particular requirements for gas, oil and solid-fuel burning appliances having electrical connections
IEC 61000-6 1/2:2005	Electromagnetic compatibility (EMC): Generic standards - Immunity for residential, commercial and light-industrial environments (1) and industrial environments (2)
IEC 61000-6 3/4:2011 + A1:2011	Electromagnetic compatibility (EMC): Generic standards - Emission standard for residential, commercial and light-industrial environments (3) and industrial environments (4)
Applied National Standards:	
DIN 4702	Heating boilers, Part 1 and 4

We hereby declare that the product in its standard design as stated here corresponds to the above provisions. The technical documentation for this product is administered by ETA Heiztechnik GmbH.

Hofkirchen, 21/05/2019

Ing. Johann Eibelhuber
Quality assurance

DI Ferdinand Tischler
Management

5 Boiler room

Installation of the boiler

The boiler may only be installed in dry surroundings. The permitted ambient temperatures are between 5 and 30 °C.

The boiler may only be installed on a flat, non-combustible surface. The distance of flammable materials in the immediate vicinity of the boiler must be heeded in accordance with national regulations.

Requirements for the boiler room

Boiler rooms must be built with fire-resistant F90 (EI90) walls and ceilings; in Switzerland EI30 up to 70 kW and EI60 over 70 kW.

An escape door to a corridor or to the outside is required. The door F30 (EI30) must open in the direction of escape and be self-closing with a tight seal. Boiler room doors that open onto escape routes must be EI90 (F90).

The boiler room must feature air inlet and outlet vents with minimum diameters for the boiler.

To prevent flue gases from escaping, it must be ensured that negative-pressure does not occur in the boiler room. Building installations, such as suction for the ventilation system or installed compressors, for example, are thus not permissible.

Floor characteristics

The boiler may only be installed on a flat, non-combustible floor. The floor must be capable of supporting the boiler's weight. For more information see the chapter [2 "Technical data"](#).

Sufficient lighting in boiler room

The boiler room must have lighting sufficient for the installation and commissioning of the boiler.

There must be no heating appliances in the vicinity of escape routes

Boilers may not be installed in stairwells, corridors or rooms through which escape routes lead to the outside.

Free minimum cross sections for the air intake openings

The boiler requires air for combustion. That is why free minimum cross sections are required in the boiler room for the air intake openings. In Austria, these are defined in ÖNORM H 5170, see the following table.

Boiler output [kW]	Free minimum cross sections in cm ²		
	Austria (specification from ETA)	Germany	Switzerland
20	400	150	206
30	400	150	309
40	400	150	412
50	400	150	515
60	400	170	618
70	400	190	721
90	400	230	927
110	440	270	1133
130	520	310	1339
180	720	410	1854
200	800	450	2060
350	1400	750	3605
500	2000	1050	5150

Tab. 5-1: free minimum cross sections

 A protection grille at the air intake opening also reduces the free cross section. Therefore, the air inlet opening must be larger depending on the protection grill. In air ducts through channels a calculation by a specialist is required.

The values listed may vary from country-specific and national regulations. Enquire about it at your authorities. If no rules exist, we recommend the Austrian minimum cross sections to use as a guide.

 Too small-sized air inlet openings may result to low pressure in the boiler room. This can lead to a reduction of the boiler output, as well as to an exit of flue gas in the boiler room.

 Boilers that are operated with an external air supply require no further supply air and outlet openings in the boiler room.

6 Safety

6.1 General information

Operation only by trained personnel

The product may be operated by trained adults only. Training may be provided by the heating technician or our customer service. Please read the associated documentation carefully in order to avoid errors during operation and maintenance.

Persons who lack experience and knowledge as well as children may not operate, clean, or maintain the product.

Keep children away from the fuel store and storeroom

In fuel stores for wood chips, in particular, there is a danger that a hollow space may form above the agitator. Children playing on the pile of wood chips, or careless adults, could fall in and get buried or caught up in the discharge screw.

Keep fire extinguishers in a clearly visible location

In Austria, the minimum requirement is an ABC powder extinguisher with 6 kg. An AB foam extinguisher with 9 litres, which produces less damage when used, is preferable. The fire extinguisher should be kept outside the boiler room, visible and easily accessible. Even if country-specific regulations do not prescribe a fire extinguisher, we still recommend that you keep one in-house.



Fig. 6-1: Fire extinguisher

Storage of ash

The ash must be kept in non-flammable containers with covers for cooling. Never put hot ash into the waste bin!



! DANGER!

Do not carry out work on high voltage units



The housing of the high voltage unit may not be opened or damaged as there are parts inside it that are under high voltage.

► Non-compliance with the above may result in serious or fatal injuries.

! DANGER!

Caution high voltage!



The electrode inside the precipitator can still have residual voltage even after switching off the power supply.

► Therefore, switch off the boiler at the mains switch and ensure that it cannot be switched back on before starting work. Then establish additional earthing between the electrode on the inside and the housing of the precipitator.

6.2 Safety devices

Pump safety run, automatic heat dissipation at overtemperature

If the boiler temperature exceeds 90°C (factory setting) for any reason, the pump safety run will start. All heating pumps and boiler pumps that are connected to the boiler control system are switched on to dissipate heat from the boiler.

This action prevents the boiler temperature from rising further and triggering further safety devices such as the safety temperature limiter and the thermal relief valve.

i The heat dissipation is limited by the maximum flow temperature set in the heating circuits and the target hot water temperature.

Install thermal emergency cooling valve against overheating

The safety heat exchanger built into the boiler must be connected by the heating technician to the house's cold water supply via a thermal relief valve to protect the boiler against overheating if the pump fails. The minimum pressure in the cold water pipe must be 2 bar and the temperature must not exceed 15 °C.



Fig. 6-2: Thermal emergency cooling valve

Only thermal emergency cooling valves that correspond to the standard DIN EN 14597 (or comparable standards) may be installed. They must activate at 100 °C and have a flow rate of at least 2.0 m³/h. The clear width of the cold water supply and outlet may not fall below the nominal diameter of the safety heat exchanger.

The cold water supply must be connected to the upper connector of the safety heat exchanger; the lower connector serves as an outlet to the sewer. To prevent

the supply line from being shut off accidentally, remove the levers from ball valves or the hand wheels from valves and hang them there with a piece of wire.

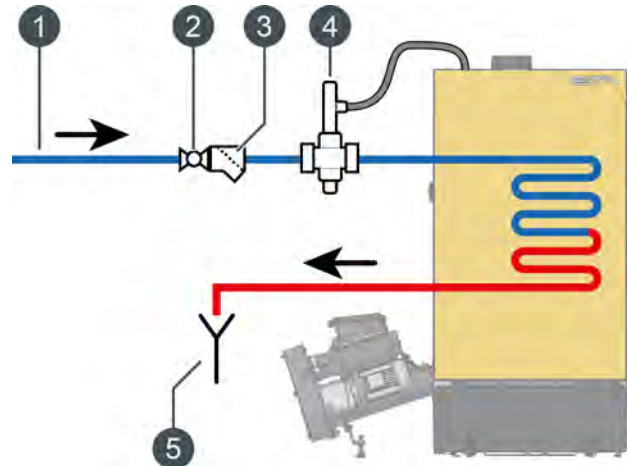

Fig. 6-3: Thermal emergency cooling valve

- 1 Cold water connection
- 2 Isolating valve; remove hand wheel
- 3 Strainer
- 4 Thermal emergency cooling valve
- 5 Visible outlet to sewer

The outlet must have an easily visible flow path so malfunctions can be recognised. Direct the discharged water to the sewer via a siphon funnel or at least with a pipe into the ground so that nobody can be scalded if the valve is activated.

Even for cold water coming from a domestic well with its own pump, a thermal emergency cooling valve must be installed on the boiler. With a generously dimensioned air vessel, enough water for cooling will come even if there is a power failure. If the power supply is very uncertain, a dedicated air vessel for the thermal emergency cooling valve is required.

Safety shutdown by safety temperature limiter

For additional safety against boiler overheating, a safety temperature limiter is built into the boiler. When a boiler temperature of 100 °C (tolerance +0°/-6 °C) is reached, the power supply to the draught fan and the fuel intake is interrupted. When the boiler temperature decreases back below 70°C, the safety temperature limiter can be manually released for a restart of the boiler.

Installing a safety valve against overpressure

A safety valve with 3 bar opening pressure must be installed on the boiler. Every heat producer in a heating system must be protected by at least one safety valve against pressure exceeding the maximum permissible operating pressure (see EN 12828). These valves must be designed such as to ensure the maximum

permissible operating pressure that can arise in the heating system or parts thereof. The safety valve must be situated in the boiler room and be easily accessible.



Fig. 6-4: Safety valve

! DANGER!

Do not install any shut-off valves, strainers or such like between the boiler and the safety valve.

The connection size of the safety valve is determined on the basis of the heating system's maximum heating capacity, as shown in the table.

Valve size ^a Nominal diameter (DN)	Maximum heating capacity (kW)
15 (G ½)	50
20 (G ¾)	100
25 (G 1)	200
32 (G 1 ¼)	300
40 (G 1 ½)	600
50 (G 2)	900

a. The valve size is determined by the size of the inlet connection.

i A separate connection is already available on the boiler for the safety valve (see following graphic). The safety valve must be connected to it.

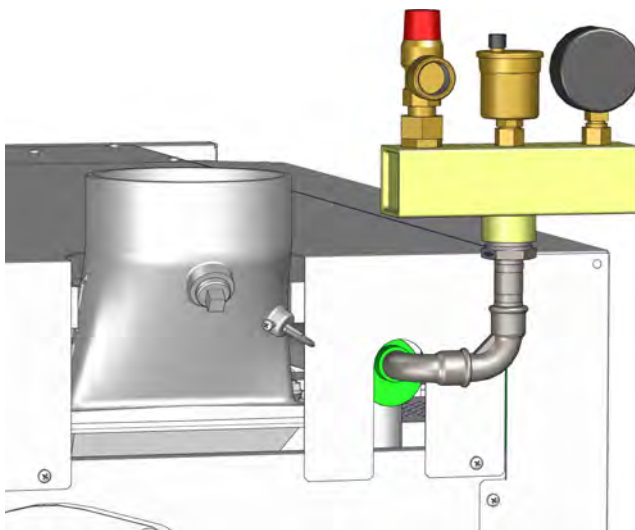

Fig. 6-5: Connection

The safety valve may be installed in any position, but the upper part of the valve must not face downward. The flow pipe may be 1 m long maximum and must be routed in a straight line in the nominal diameter of the valve inlet.

! DANGER!

Safety valve outlet

The safety valve outlet must be directed to the ground in a pipe so nobody is endangered by hot water or steam.

- ▶ The safety valve outlet (vent pipe) must have at least the same nominal diameter as the valve outlet, be installed with a consistent gradient and be routed to a sewage system (e.g. duct). The vent pipe may contain a maximum of 2 bends and be 2 m long. If a length of more than 2 m is required, the next size of pipe must be selected. More than 3 bends and 4 m of length are not permitted. The mouth of the vent pipe must allow easy inspection and be routed such as to exclude any danger to persons. If the vent pipe ends above a funnel, its discharge pipe must have a cross section at least double that of the valve inlet.

6.3 Emergency stop switch

Emergency stop switch for the boiler

The EU Machinery Directive stipulates a lockable switch for the floor agitator in the fuel store. The best way of satisfying this requirement is to design the usual emergency stop switch as a key switch. This must be located immediately outside the access door, quite a bit higher than the light switch, and clearly labelled. For boiler rooms that are only accessible from outdoors, this emergency stop switch may also be inside the boiler room, immediately next to the access doors.

A single-pole, lockable switch or key switch is integrated in the boiler's safety chain. When actuated, this only stops the supply of fuel and combustion air. The pumps continue running to cool the boiler.

Emergency stop switch for the fuel store

We recommend fitting an additional emergency stop switch in the access area of the fuel store. Installation in the jamb of the access door has proven effective. The single-pole switch is integrated in the boiler's safety chain.

6.4 Safety devices in the fuel path

European standard EN 303-5

With EN 303-5 "Heating boilers for solid fuels... up to 500 kW" safety requirements have now been harmonised across Europe.

- **Spread of fire in the fuel supply pipe.**
The one-chamber rotary valve installed as standard equipment (RSE according to TRVB 118 H) and the negative-pressure operation of the boiler prevent the propagation of fire (burn-back) in the fuel supply.
- **Heat conduction - surface temperature.**
The surface temperature of the stoker may not exceed 85°C in any operating mode. This is ensured by the one-chamber rotary valve installed as standard. Without air, burn-back into the stoker is impossible.
- **Backflow of flammable combustion products into the store via the fuel supply pipe.**
The single-chamber rotary valve installed as standard equipment and the negative-pressure operation of the boiler with a speed-controlled draught fan (DÜF according to TRVB 118 H) prevent a backflow into the fuel supply or the fuel store.
- **Shortage of combustion air or incomplete combustion.**
A shortage of combustion air is prevented by standard residual oxygen measurement (FÜF according to TRVB 118 H), speed-controlled draught fan and position feedback for the air flaps. If there is a fault in the fan or the air flaps, a safety shutdown takes place.

Fire compartments in larger buildings

If a secure fire compartment is required between the boiler room and the fuel store in a larger building, then an automatic extinguishing system (sprinkler system) must be installed in the wall opening in addition to the requirements of EN 303-5.

Regulations for Austria - TRVB 118 H

During the official approval process, the authorised inspector can require compliance with TRVB 118 H "Technical directives for preventive fire safety" (Austrian Association of Fire Brigades and Austrian Fire Prevention Bodies).

A temperature monitoring system and manually activated fire extinguishing system, in particular, are also required:

- **Temperature monitoring system**
This is installed in the wall opening of the conveyor screw from the fuel store to the boiler room; see [Fig. 6-7: "Temperature monitoring system"](#).
 In Austria, a capillary thermostat is supplied with all ETA wood chip boilers for this purpose.
- **Manually activated fire extinguishing system**
This fire extinguishing system is installed above the wall opening of the conveyor screw from the fuel store to the boiler room for fuel stores measuring over 50 m³ and whenever fuel is stored in a barn (to be installed by the contractor, if required), see [Fig. 6-8: "Manually activated fire extinguishing system"](#).

Regulations for Germany

In Germany, previous requirements only stipulated one burn-back protection device in the fuel path and pressure monitoring of the combustion chamber. Now, with EN 303-5, a much more stringent safety standard is required, which ETA also fulfils.

Regulations for Switzerland - VKF 105-03d

In Switzerland, previously a burn-back protection device (flap, slider or rotary valve) and a sprinkler system on the stoker were required. Now, with EN 303-5, a much more stringent safety standard is required, which ETA also fulfils.

Single-chamber rotary valve as standard equipment

The standard configuration of ETA wood chip boilers with patented ETA one-chamber rotary valve and induced draught technique without fan, and with combustion chamber negative-pressure in all states of operation satisfies all requirements of EN 303-5 regarding fire propagation and recirculation of gases,

as well as the requirements of TRVB 118 H. That provides reliable protection against back burning for wood chips and pellets.



Fig. 6-6: Single chamber rotary valve

Temperature monitoring system in the fuel store room

A thermostat must be installed in the wall opening for the conveyor screw from the wood chip store. It must trigger the connected warning device, such as a horn, if a temperature of approx. 70°C is exceeded. The sensor is inserted into the tube on the conveying system trough. The activation temperature of the thermostat is set to 65°C at the factory.



Fig. 6-7: Temperature monitoring system

- 1 Adjustable thermostat
- 2 Temperature sensor

Manually activated fire extinguishing system

This safety device floods the fuel store with water in the event of a fire. This system consists of non-flammable empty piping with a minimum nominal diameter of 20 mm and must be installed in the fuel store directly above the conveying system. The empty piping must

be connected to a pressurised water supply and equipped with a shut-off valve (a ball valve, for example), and labelled "Fire extinguisher for storeroom".

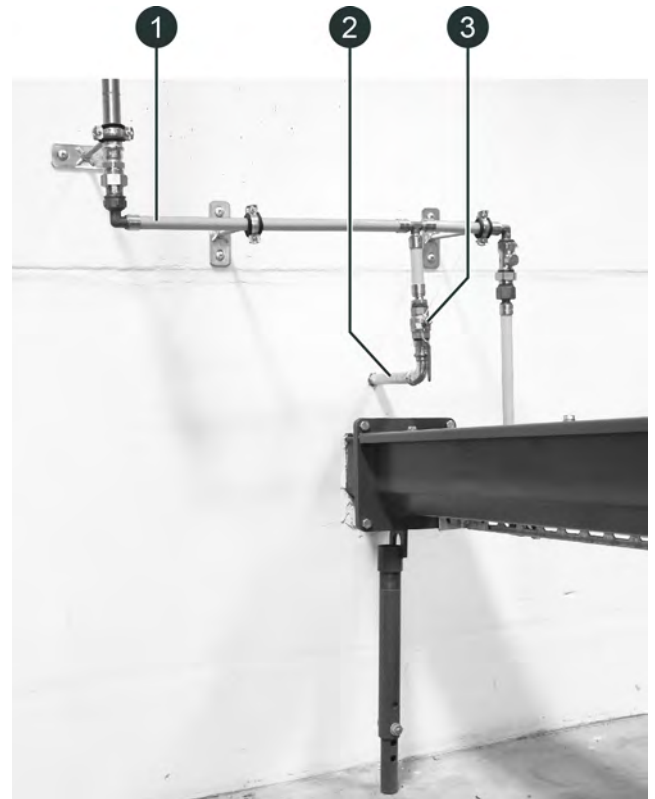



Fig. 6-8: Manually activated fire extinguishing system

- 1 Water supply
- 2 Empty piping (minimum nominal diameter 20 mm) in the fuel store
- 3 Ball valve

Thermally activated sprinkler as automatic extinguishing system

 The following graphic shows the connection for the automatic extinguishing system. This extinguishing system can be prescribed in certain countries. It is installed above the rotary valve, so it can

automatically stop burn-back inside the conveying system by flooding both screws. It works without electricity. The activation temperature is 97 °C.

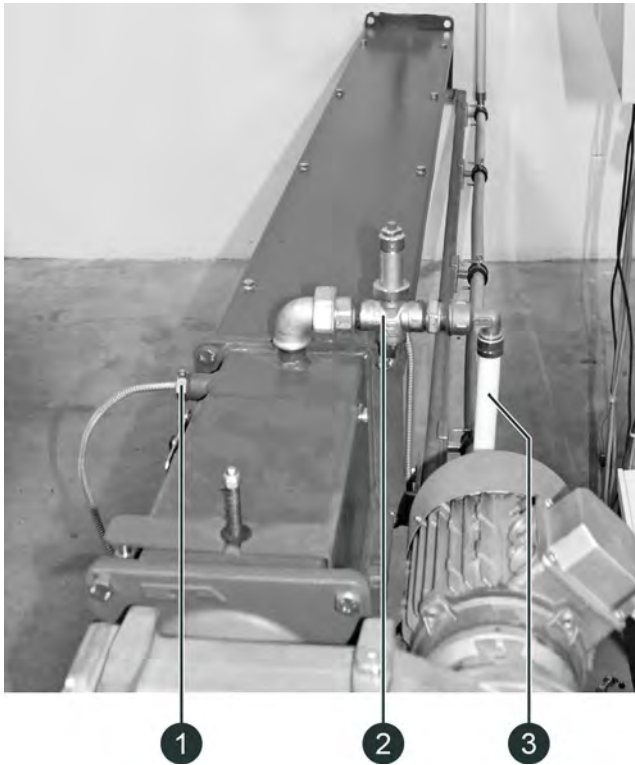



Fig. 6-9: Automatic extinguishing system

- 1 Temperature sensor
- 2 Thermally activated sprinkler system
- 3 Water supply

The sprinkler system must be connected either directly to a pressurised water supply or to a water tank. A strainer with isolating valve (only operable with tools) must be installed in the water pipe. The pipe conducting the water supply to the conveying system must be fireproof.

 In the case of a water tank, the stored volume of water must be three times the volume of the feed system (= fuel discharge) or at least 20 litres. The tank must be equipped with a filling level monitor that can trigger an acoustic or visual alarm.

Securing the fire compartment in larger buildings or between a house and barn

An open fire in the boiler room can ignite the fuel in the discharge screw. This can cause the fire to spread to the store. If the boiler room and store are in the same fire compartment, special measures are unnecessary. If a fuel conveyor screw goes through the wall separating two fire compartments, then special measures are needed. The fire protection insulation recommended by the relevant standards for the conveyor screw in this situation is exposed to a high risk of damage due to the required maintenance

openings, and so is not truly safe. An automatic sprinkler and a fire alarm (temperature-monitoring system) with lower activation threshold than the sprinkler, installed in the wall opening, provides a considerable increase in safety.

7 Information for installation

7.1 Chimney

7.1.1 Planning and layout

Required chimney diameter

Please note that in partial-load operation the exhaust temperature is lower and the large chimney diameters, normally used for solid fuel, are no longer ideal. If the cross section is too large, the flue gas no longer safely rises from the chimney opening and may flow along the roof and sink to the windows of the living quarters.

 The flue gas connection on the boiler has two different diameters (see table). The flue gas connection with DN200 must not be used with this boiler. The flue pipe from boiler to chimney must be executed as per the requirements in the table. A flue pipe with 2 m length and two 90° bends was assumed for the calculation. The "X" marks any diameters which may not be used.

Example: eHACK 200 with 8 m chimney height and DN250 flue pipe => a chimney with 30 cm diameter is required.

 No cross-sectional taper is permitted, such as a DN250 connection pipe in a chimney with a 20 cm diameter.

Diameter of the flue pipe from boiler to chimney	Chimney height above the boiler room floor	Required chimney diameter in cm			
		eHACK, ePE-K 180	eHACK, ePE-K 200	eHACK, ePE-K 220	eHACK, ePE-K 240
DN 200 DN 250	6 m	X 30 ^a	X 30 ^a	X 30 ^a	X 35 ^a
DN 200 DN 250	7 m	X 30	X 30 ^a	X 30 ^a	X 30 ^a
DN 200 DN 250	8 m	X 30	X 30	X 30	X 30 ^a
DN 200 DN 250	9 m	X 30	X 30	X 30	X 30
DN 200 DN 250	10 m	X 25	X 30	X 30	X 30
DN 200 DN 250	11 m	X 25	X 25	X 30	X 30
DN 200 DN 250	12 m	X 25	X 25	X 25	X 30
DN 200 DN 250	13 m	X 25	X 25	X 25	X 30
DN 200 DN 250	14 m	X 25	X 25	X 25	X 25

a. For boiler outputs over 30 kW and low chimney heights, a chimney joint tilted 45° can help achieve the required draught of 5 Pa at full load with acceptable cross-sections (a size smaller than indicated in the table).

Clarify with the chimney sweep

A specialist or a chimney sweep must inspect the dimensions and suitability of existing chimneys especially before boiler installation.

Every boiler must have its own chimney

The better the boiler and the chimney are matched, the greater the energy with which the flue gas exits the chimney, and therefore the certainty that it will rise up into the air.

If the diameter is too large, the chimney will not be heated sufficiently, and the exit velocity and temperature will be too low. The flue gas then lacks the energy to rise and, in extreme cases, the smoke can sink down along the roof.

Chimneys with a diameter more than 50% greater than needed must be renovated to reduce the diameter. If a chimney is designed for use with two simultaneously operating boilers, it may prove to be oversized for the partial load from only one boiler. If there really is only one chimney available, a buffer storage tank can help avoid an overly small partial load.



DANGER!

Do not connect fan-assisted boilers and wood-burning stoves to the same chimney

Although not expressly prohibited, connecting a fan-assisted boiler and a wood-burning stove to the same chimney is a dangerous combination. For every wood-burning stove has an air intake. When the chimney is cold, any fan-assisted boiler, whether it burns oil or wood, will blow flue gas through this opening into the living area. If the wood-burning stove's firebox door is not closed and the boiler is defective at the same time, acute carbon monoxide poisoning is even possible.

Wood-burning stoves require a considerably larger chimney diameter, which cannot be heated by the fan-assisted boiler. Cold flue gas does not rise from the opening; it sinks and can reach living quarters through open windows. Moreover, it may be possible to hear the boiler's fan in the living quarters through the wood-burning stove.



DANGER!

Do not connect fan-assisted boilers and gas boilers to the same chimney

Most gas-fired boilers do not have a sealed air flap, and if the fan-assisted boiler is started when the chimney is cold, the flue gas is pushed through the gas boiler into the boiler room. This is not greatly helped by a flue gas damper in the flue pipe of the gas boiler, as these dampers are not certain to seal well on closing.

In the case of atmospheric gas boilers, old fireclay chimneys only stay dry due to the gas boiler's overflow opening. The water from the flue gas condenses in the chimney. During heating pauses, air flows through the overflow opening and dries the chimney. If this air flow is blocked by a flue gas damper, the moisture can destroy an old fireclay chimney.

Obsolete regulations stipulate the wrong chimney

Laws and regulations demand a moisture-resistant flue system for oil and gas and one that is resistant to soot fires for solid fuels.

Wood is a solid fuel. However, in the lower output range, the temperature of the flue gas can be below 100°, and condensates can be deposited in the chimney. The chimney must therefore be moisture-resistant, "contrary to regulations". Builders making a chimney resistant to soot fires in compliance with the law must then look on helplessly as the condensate destroys the chimney wall.

Soot fires are possible in natural-draught boilers or wood-burning stoves regulated by throttling the air supply. When the wood fire is at full intensity and the boiler temperature has been reached, a thermostat closes the air flap. This stops combustion. However, as the combustion chamber temperature doesn't fall, the wood continues to gasify. Unburned wood gas condenses to tar in the chimney, which can be ignited by sparks from the fire.

With modern, lambda-controlled wood boilers, soot fires of this kind are virtually impossible, as the control system restricts wood gasification, not the air. In modern, lambda-controlled wood boilers, the control system shuts down the fire by stopping the fuel supply, without closing off the supply of air to the fire. This way, there is no lack of air and no flammable tar in the chimney. In addition, the low flue gas temperatures of modern wood boilers also provide no ignition source for a soot fire. Modern and properly maintained wood boilers therefore pose no danger to chimneys from soot fires.

Moisture-resistant W3G flue systems

Since 2005, W3G chimneys (classified according to the German DIN 18160) exist that are resistant to both moisture and soot fires. These chimneys are approved for all fuels. Most of these W3G chimneys have ceramic inner pipes, which have a significantly longer service life than metal chimneys due to their acid resistance.

Connecting pipe to chimney preferably stainless steel

Due to the low exhaust temperatures, we recommend using a moisture-resistant stainless steel flue pipe as the connecting pipe to the chimney.

Provide a short, ascending flue pipe to the chimney

The flue pipe from the boiler to the chimney must be short, leakproof and ascending. "Attractive" right-angle flue offsets with two or more bends are bad in a flue

pipe. The optimum to strive for is the shortest pipe from the boiler to the chimney with a minimum of direction changes.

The flue pipe to the chimney must be leakproof. For unsealed sleeve pipes, use heat-resistant silicone as a sealant. Otherwise, you can expect smoke to escape into the boiler room as the boiler heats up. Ensure the flue pipe always ascends to the chimney

Long horizontal flue pipes to the chimney must have a narrow diameter and above-average insulation (>50 mm). Provide enough cleaning apertures in the flue pipe. A flue pipe to the chimney with a large diameter would reduce the necessary calculated chimney diameter. However, with low flow speeds ash deposits will form, and the theoretically calculated flue draught will be lost again.

If the chimney has a large diameter, the straight length of the connecting pipe can be at maximum half of the effective chimney height (calculation required).

A draught limiter is required for boilers with flue gas recirculation

If the boiler is equipped with flue gas recirculation, such as the PE-K pellet boiler (or eHack wood chip boilers with optional flue gas recirculation), a draught limiter must always be installed in the chimney.



Fig. 7-1: Draught limiter

i Flue gas recirculation conveys a portion of the flue gas back to the boiler to cool the combustion chamber. An overly strong flue draught prevents the recirculation to the boiler and the flue gas reaches the

chimney immediately, thus rendering the flue gas recirculation ineffective. This leads to slag formation and increased wear on the boiler.

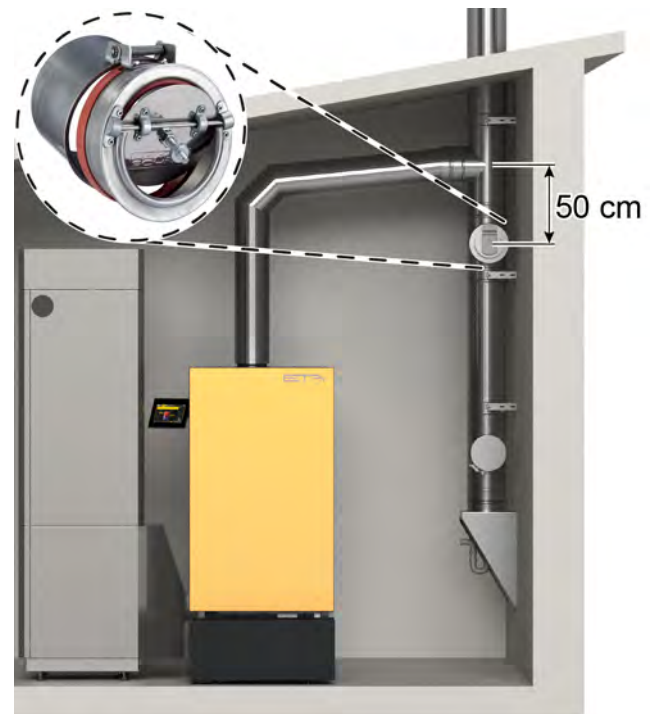

Fig. 7-2: optimum placement of the draught limiter

At a minimum, the draught limiter must correspond to the diameter of the chimney and should optimally be connected 0.5 m below the flue tube connector in the chimney. If that is not possible, installation in the connection pipe to the chimney is required. Example:
Chimney: dia. 220 mm
Connection pipe to chimney: dia. 180 mm
=> a draught limiter of at least 220 mm diameter is required.

Connection to the sewage system for the chimney

For the condensate in the chimney, a connection to the sewage system (e.g. duct) with at least DN25 via a siphon is required. The sewer pipe to which the condensation drain pipe is connected should be flushed once a year.



Fig. 7-3: Condensate drain

i For chimneys on the outer walls (made of stainless steel, for example), frost-proof run-off must be provided for the condensate water.

Insulate the connecting pipe to the chimney

The connection between the boiler and the chimney should be insulated with at least 30 mm, preferably 50 mm, of mineral wool to avoid thermal losses, which can lead to a build-up of condensation.

Prevent structure-borne noise

To prevent structure-borne noise as far as possible, there should not be a fixed connection between the flue pipe and the chimney. Good flue systems are acoustically isolated. When steel pipes are connected to a fireclay chimney, ceramic fibre bandages have proven effective at preventing structure-borne noise as well as damage to the refractory sleeve.

Cleaning aperture in the connecting pipe

Easily accessible cleaning apertures must be available for cleaning the flue pipe.



Fig. 7-4: Cleaning aperture

Fit the chimney connection just under the ceiling

Even if the current boiler can be connected to the chimney at a low height, it is better if you fit the chimney connection just below the ceiling. The flue pipe is easier to install, and the vertical connecting pipe is long enough for an emission measurement.

i A second chimney connection below the first one enables simple installation of a draught limiter, if this is required.

Opening for the emission measurement

A self-locking and sealing measurement opening must be provided in the flue pipe to facilitate emission measurements. The measurement opening must be designed in accordance with national directives.

Deflagration damper

The boiler is designed with safety routines in the control system to prevent deflagrations. So for a boiler output up to 50 kW no deflagration damper (also often called a blowback flap) is required if the connecting pipe is short and ascends to the chimney.



Fig. 7-5: Example: deflagration damper with draught limiter

From 60 kW boiler output, we recommend using an deflagration damper. From 100 kW boiler output, an deflagration damper is required. While the most that

can happen when there is a deflagration in a smaller boiler is that the connecting pipe to the chimney can be pulled apart, for larger boilers the gas volume is so large that a boiler door can be blown off.

For high points before descending sections or at the beginning of a long horizontal section ($L > 20 \times D$), a deflagration damper is required regardless of the boiler output.



DANGER!

Position of the deflagration damper

- ▶ Position the deflagration damper so that no people are endangered.

7.1.2 Renovation

Chimney renovation before it's too late

Compared to older boilers, modern ones are more efficient and have lower amounts of flue gas and considerably lower temperatures.

Chimneys with a "too large diameter", in particular, can no longer be heated adequately. The moisture contained in the flue gas condenses in the chimney, resulting in the very slow but inexorable destruction of old masonry chimneys.

Furthermore, the exit velocity and temperature are too low if the diameter of the chimney is too large. The flue gas then lacks the energy to rise and, in extreme cases, the smoke can sink down along the roof.

If your chimney does not have a moisture-resistant liner or its diameter is too large, it will require renovation in the form of a new, moisture-resistant liner. Narrow chimneys can also be renovated by the addition of stainless steel pipes.

Also keep in mind that chimneys have a limited service life. Timely renovation before destruction of the chimney wall can be achieved quickly and easily by inserting a tube. But if the flue gas condensates have penetrated the mortar joints, the entire chimney must be dismantled and rebuilt.

Chimney renovation with a stainless steel pipe

Maybe the chimney has already been renovated for oil or gas with a stainless steel pipe, and now a conversion to wood or pellets is planned. Or the chimney is too narrow to install a ceramic pipe with a reliable seal. If a moisture-resistant inner pipe is installed in a sufficiently fire-resistant casing, the German Association of Chimney Sweeps has found the following solution to the standards and regulations dilemma: "in the certification of suitability and safe use for heating systems, it should be noted that after a soot fire the long-term durability cannot be ensured and

penetration of the chimney by moisture cannot be ruled out so that it may be necessary to replace the inner pipe (Criteria for Determination of Suitability and Safe Use of Heating Systems - October 29th 2008, page 12).

Replace inner pipe after a soot fire

After a soot fire, the inner pipe is in all likelihood no longer sufficiently leakproof, making the chimney subject to damage by moisture. In this case, the inner pipe needs to be replaced without fail, regardless of whether its resistance to soot fires has been checked or not.

7.2 General information

Approval

All heating systems require approval. Enquire at your building authority and ask your chimney sweep.

Antifreeze

If the building is unoccupied for longer intervals in winter, up to 30% antifreeze can be added to the heating water. To compensate for the disadvantage of reduced heat capacity and increased flow resistance, only slightly higher flow temperatures are needed.

Insulate contact sensors

If the pipe in the vicinity of a contact temperature sensor is not insulated (e.g. in externally installed heating circuit assemblies), lower than actual temperatures will be measured. For this reason, the pipe insulation of heating circuit flow sensors must not be recessed or weakened. For uninsulated pipe systems, mineral wool insulation at least 20 mm thick is required for the measurement area over a pipe length of 20 cm minimum.

7.3 Water hardness

Determine permissible water hardness for the heating water according to ÖNORM H 5195-1

Specific water content in litre/kW		Table 1 Heat producer with large (> 0.3 l/kW) water content			Table 2 Heat producer with small (> 0.3 l/kW) water content		
		< 20 l/kW	≥ 20 l/kW < 50 l/kW	≥ 50 l/kW	< 20 l/kW	≥ 20 l/kW < 50 l/kW	≥ 50 l/kW
Total output of the heat producer	≤ 50 kW	16.8 °dH	11.2 °dH	5.6 °dH	11.2 °dH	5.6 °dH	0.6 °dH
	> 50 kW ≤ 200 kW	11.2 °dH	5.6 °dH	2.8 °dH	5.6 °dH	2.8 °dH	0.6 °dH
	> 200 kW ≤ 600 kW	5.6 °dH	2.8 °dH	0.6 °dH	2.8 °dH	0.6 °dH	0.6 °dH
	> 600 kW	2.8 °dH	0.6 °dH	0.6 °dH	0.6 °dH	0.6 °dH	0.6 °dH

Instructions for determination:

1. Divide water content (litres) of the heat producer by its output in kW. If the result is larger than 0.3 l/kW, Table 1 applies. If the value is smaller or equal to 0.3 l/kW, Table 2 applies.
2. Divide the total heating water volume (in litres) by the output (in kW) of the smallest heat producer. The result is the specific water content and this determines the column within the previously calculated table.
3. Read the data for the permissible water hardness from the respective line using the total output of the heat producer.

Example: A heating system with a 45 kW boiler and 1500 litre total water volume.

1. The ratio of water content to output is more than 0.3 l/kW ($1500:45=2.6$) => Table 1.
2. The specific water content is 33,3 l/kW ($1500:45 = 33.3$) => middle column in Table 1.
3. The total output of the boiler is 45 kW; therefore, only the data from the first line (≤ 50 kW) are relevant.

The permissible water hardness in this example is 11.2 °dH.

Softening with a salt-regeneration ion exchanger

We recommend softening water with salt-regeneration ion exchangers, just as drinking water is softened. This method does not remove salt from the water. It replaces the calcium in the lime with sodium from the salt, and has considerable advantages. It is cheap and chemically stable against contamination. In addition, it produces a natural alkalinity that generally results in a sufficiently non-corroding pH value of around 8.

pH value between 8 and 9 may require dosing with trisodium phosphate

If the heating water's pH value has not itself changed to more than 8 after a week of operation, increase it by adding 10 g/m³ of trisodium phosphate (Na₃PO₄) or 25 g/m³ of trisodium phosphate dodecahydrate (Na₃-PO₄·12H₂O). Wait another 2-4 weeks before making further corrections. The pH value must not exceed 9.

No hybrid installations

A disadvantage of salt-regeneration ion exchange is the salt content with its high electrical conductivity, which can lead to electrolytic corrosion, especially of aluminium or galvanized steel. If only steel, brass, gunmetal and copper are used in the heating system and the use of stainless steel is limited to small areas, then no corrosion problems should be expected, even with salty water.

Galvanized and aluminium parts in a heating system are always in danger of corrosion, especially in combination with copper tubing. In practice, this means no hot-galvanized fittings and no mixing of galvanized tubing with copper tubing. There is an illogical exception: galvanized steel tubing combined with boilers or buffer storage tanks made of steel. Presumably, the uniform zinc layer dissolves uniformly and is dispersed evenly throughout the system without localised corrosion.

Complete desalination not required

If there is no aluminium (heat exchanger in the gas boiler or aluminium radiator) in the system, then costly complete desalination with ion exchange cartridges or osmosis is not required.

Lime stabilisation can be dangerous

The addition of lime stabilising agents prevents limescale. However, we advise against doing this. These agents increase the salt content and result in an undefined pH value. If the system is filled with large amounts of water, exactly the same agent must be used again. Mixing with other water additives or with antifreeze can result in corrosion.

7.4 Corrosion

Initial protection with corrosion inhibitors

These agents line the new and still uncoated internal surfaces with a protective film. This is only possible in a new system. If corrosion has already begun, these agents can no longer be of help. Use corrosion inhibitors sparingly.

For systems with buffers with a large water volume relative to the internal surfaces, it is preferable to use half rather than double the quantity specified by the manufacturer.

7.5 Bleeding

Protection against atmospheric corrosion

To reliably protect the entire heating system against corrosion, air intrusion should be kept to a minimum and any air that does gain entry must be released as soon as possible.

Bleeding at the highest point of the flow

No system is completely airtight. Air that gets into the system is transported to the boiler with the return flow since water can take up more air as it gets colder and as the pressure increases. The air is released again at the point in the system with the highest temperature and the lowest pressure. The two typical points for releasing gas are the hot boiler and the highest point in the heating system flow.

 For boilers of the eHACK series, a separate connection is available on the boiler for the safety valve, pressure gauge and bleed valve. The piping to the safety valve and the bleed valve must be

dimensioned the same as the boiler connection. Also place a bleed valve at the highest point in the flow of the overall system.

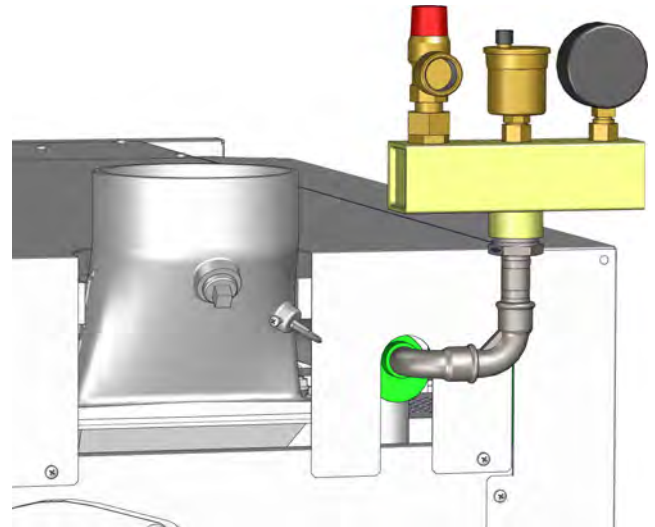

Fig. 7-6: separate connection

For large, unseparated underfloor heating systems, an absorption filter for the entire water flow should be installed in the flow after the boiler (Spirovent, Flamco and Pneumatex are typical manufacturers).

Impermeable plastic tubing or system separation

Plastic tubing which is used must have DIN 4726 certification. As a rule, this is documented with a DIN test mark and a register number in the pipe label. Underfloor heating systems from older construction years often do not meet the requirements of the DIN standard from 1988. A considerable input of oxygen is to be expected here. The oxygen introduced can have a corrosion-promoting effect on various components in the heating system. A separation of the existing underfloor heating from the new boiler is required here. Although the limit values are not reached, the sum of the oxygen input via surface heating system, distribution, leakages, replenishment, etc. can also cause corrosion damage, especially in large systems (pipe lengths over 5000 running metres). A separation of the surface heating system from the heating boiler is

recommended here. If damage to the boiler caused by the introduction of oxygen is proven, all claims under warranty and guarantee are void.

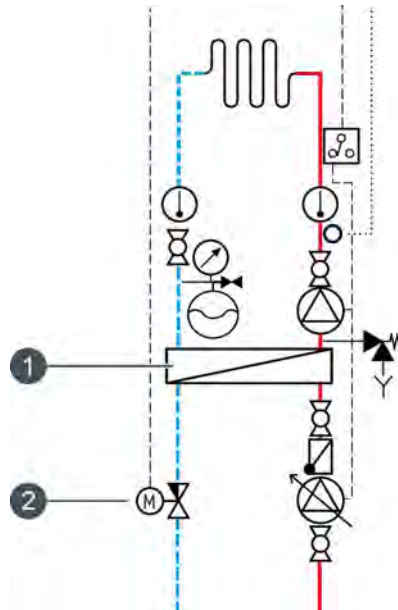

Fig. 7-7: System separation

- 1 Heat exchanger
- 2 Control valve

i The hydraulically correct incorporation of the heat transfer station (regardless of whether for system separation or as a transfer station) must be adjusted on the primary side. In order to achieve optimal flow based on the flow temperature, the use of a two-way control valve (see graphic above) is recommended. Additionally, the primary pump should be designed with differential pressure control. A system separation module with these specifications is available from ETA.



Fig. 7-8: ETA system separation module

No open expansion tanks

Open expansion tanks improperly allow air into the system. Existing systems with open expansion tanks must be redesigned or physically separated from the boiler.

i Pressureless buffer storage may not be attached directly to the boiler. If it is not possible to replace this buffer, there must be a physical separation between the boiler and the pressureless buffer.

7.6 Pressure equalisation

An expansion tank is needed

To equalise pressure in the system, a diaphragm expansion tank with a gross capacity of around 10% of the system volume is required. If the pressure difference between cold and warm heating system (buffer fully loaded if installed) is greater than 1.0 bar for a single-storey system or 0.5 bar for a three-storey system, then the expansion tank is too small and absolutely must be replaced with a larger one. If the installed expansion tank is not large enough, the system sucks in air when cooling and the air is absorbed by the cold water and transported to the boiler. At the point of highest temperature, the air separates from the water again. This usually takes place in the boiler, and the inevitable result is that the boiler wall will rust through in these spots.

Adjust expansion tank preset pressure

Most expansion tanks are delivered with primary pressure of 1,5 bar. Adjust the pressure by releasing nitrogen so that it is 0.3 bar higher than the static pressure at the installation location, but make sure the pressure does not fall below 0.9 bar.

- Example 1:
height difference between expansion tank and highest point in the system $p_{st} = 11 \text{ m} = 1.1 \text{ bar}$:
 $1.1 \text{ bar} + 0.3 \text{ bar} = 1.4 \text{ bar}$ pressure setting.
- Example 2:
height difference between expansion tank and highest point in the system $p_{st} = 5 \text{ m} = 0.5 \text{ bar}$:
 $0.5 \text{ bar} + 0.3 \text{ bar} = 0.8 \text{ bar} \rightarrow 0.9 \text{ bar}$ pressure setting.

Here, the minimum pressure of 0.9 bar must be selected. The factory setting of 1.0 bar for the cut-off pressure is compatible with this minimum pressure setting.

Protect the expansion tank against shut-off

All shut-off valves along the path from the expansion tank to the boiler and to the buffer storage tank must be capped valves, or the hand wheels or levers must

be removed from the valves (hang on the valve with a wire), to ensure that they cannot be closed inadvertently.

7.7 Noise emission

Airborne noise emission

In normal operation, the airborne noise emissions from a pellet or wood chip boiler is between 40 and 50 dB(a) with individual peaks of up to 75 dB(a) (ignition fan and pellets vacuum motor).

To limit airborne noise emissions, the usual measures that are required for all boiler rooms are sufficient:

- Heavy doors such as the legally prescribed fire doors
- Restriction of the air intake openings to the required minimum
- Sound absorption insulation in the floors of the rooms above

Structure-borne noise

Noise problems with pellet or wood chip boilers are primarily caused by structure-borne noise emissions, that is from the noise energy that is introduced into the building. The main structure-borne noise emission sources and required damping measures are listed in the following.

- **Squeaking and creaking of the fuel conveyor screws:**
Squeaking and creaking from the fuel conveyor screw depends on the fuel used, which is why the volume can have a wide range. Even if these noise sources are negligible in 90% of systems, without measures to counteract structure-borne noise transmission, the limit value of 30 dB(a) (for domestic technical systems) can be exceeded in the adjacent living rooms for 10% of systems. For this reason, cover the screw in the wall opening with mineral wool to prevent noise being introduced into the wall. In the same way the store room should be set up on a floating screed to acoustically decouple the conveyor from the building.
- **Chimney noises through the draught fan:**
For chimney noises through the draught fan, a soft integration (for example with a ceramic cord) of the flue gas conduit is used in the chimney connector for soundproofing.
- **Natural resonance of the chimney:**
The natural resonance of a chimney occurs if the chimney emits a certain frequency from the boiler (pipe organ effect). As soundproofing for brick-built chimneys, additional insulation and sealing of the

cleaning aperture helps. For metal chimneys, additional wall consoles attached to the walls can help.

- **Noise emission through heat exchanger cleaning of the boiler:**

For soundproofing, blocking de-ashing during night hours with the time programme available on the controller helps. So does a floating screed in the boiler room and setting up the boiler on the ETA sound-insulation set. Design the rigidly connected installation (flow and return, thermal emergency cooling valve) so that introduction of noise into the wall is minimised.

8 Buffer storage tank

8.1 General information

Finely adjustable radiator valves and fresh water module

The lower the return temperature to the buffer, the greater its heat storage capacity. The buffer utilisation of radiators can be improved considerably with very finely adjustable thermostat valves (kvs less than 0.35).

With a fresh water module, the hot water supply can be integrated in the buffer to save space, and a solar heating system can also be integrated with the buffer very simply and effectively.

Buffers for multi-boiler systems

For systems with several boilers and also for those with several very different heating circuits (especially different times of operation or air and underfloor heating in the same heating system), a bypass is needed between heat producers and consumers to ensure stable hydraulic conditions for the individual circuits. A hydraulic bypass is nothing more than a pipe connection between the flow and the return with the same diameter as both. The differential water quantities from heating and boiler circuits flow through this bypass. This results in a neutral pressure point that ensures that the heating circulation cannot influence the boiler water circulation and vice versa.

A bypass that can do more than just stabilise pressure conditions is the buffer. If a wood boiler for the base-load range and an oil/gas boiler for peak load or as emergency reserve are operated together in a heating system, a buffer storage tank reduces the operating time of the peak-load boiler by compensating for brief differences between production and consumption. The number of boiler starts/stops when consumption fluctuates around the rated output of a boiler is reduced, saving energy and easing stress on the boiler.

To work as an output compensator and bypass for several boilers, the buffer's storage capacity should be chosen to match 20 to 30 minutes of full-load operation for the largest automatic wood boiler in the system. In special cases, peak loads and non-continuously operated air heating systems must also be taken into account, or the morning peak if the start of an oil/gas boiler is to be avoided. Whereby "first", the morning peaks themselves should be minimised with staggered starting times for the heating circuits as well as reasonable set-back temperatures.

Choosing buffer size for systems with automatic fuel supply

Even if some subsidy guidelines demand "litres per kilowatt" and thereby specify a minimum buffer size, one should arrange for a technically correct size. The storage capacity of a buffer essentially depends on the spread between the heating system's boiler flow temperature and return temperature.

Example: For a 90 kW boiler with 70°C flow temperature, 30 minutes of full-load operation with underfloor heating and 30°C return temperature (= 40°C spread) requires a buffer volume of 968 litres, but with radiator heating and 50°C return temperature (= 20°C spread), it requires 1,935 litres.

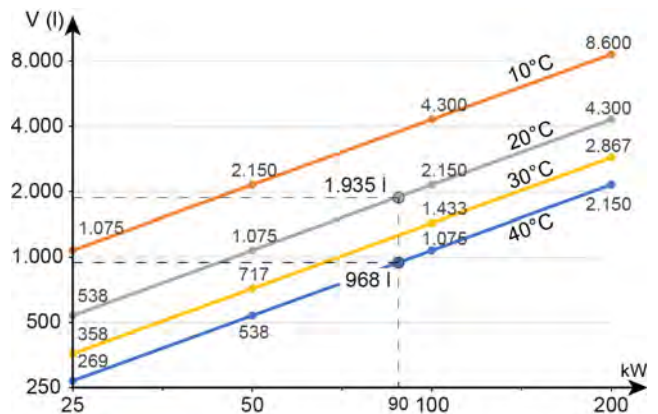

The minimum volume for the buffer can also be calculated with the following formula:

$$\text{Volume} = \frac{\text{operating time (h)} \times \text{output (kW)} \times 860}{\text{spread (}^\circ\text{C)}}$$

Switzerland: Air Quality Control Regulation

In Switzerland, the Air Quality Control Regulation "LVR" requires that heating boilers have a minimum volume for heat accumulators (buffer). For the calculation, a distinction is made between manually and automatically operated boilers.

- For a manually operated boiler (e.g., log boiler) up to 500 kW rated capacity, there needs to be at least 12 litres of buffer volume for each litre of fuel filling chamber. The volume must not exceed 55 litres per kW rated capacity.

Which is why a SH30 boiler (150 litres filling chamber) needs a buffer volume of 1800 litres (=150x12). A SH60 (223 l filling chamber, 223x12=2676 l) requires at least 3300 litres (=60x55) buffer volume.

- An automatic heating boiler up to 500 kW rated capacity requires a minimum buffer volume of 25 litres per kW rated capacity. Hence, a wood chip boiler with 100 kW needs a minimum buffer volume of 2500 l (=100x25).
 However, pellet boilers up to 70 kW rated thermal input are exempt from this regulation.

8.2 Hydraulic integration

Hydraulic integration of a buffer

For the largest possible buffer storage capacity and for maximum solar yield even in winter, low return temperatures from the consumers are the goal.

Even the best stratified buffer can't unmix what has been mixed by heat distributors. Particularly in houses where radiators and underfloor circuits are present, no mixing heat distributors should be installed; the returns should be connected directly to the buffer. An underfloor heating system can still be operated with the return from radiators.

If a solar heating system is connected, only the cold returns from an underfloor heating system or from a fresh water module may be fed into the solar-heated lower third of the buffer. This results in lower solar panel working temperatures with significantly higher efficiencies and also significantly higher solar yield.

In all cases, an oil or gas boiler should be connected at the top part of the buffer only.

Siphon loops downwards at all connections reduce heat losses in summer.

With hot water tank

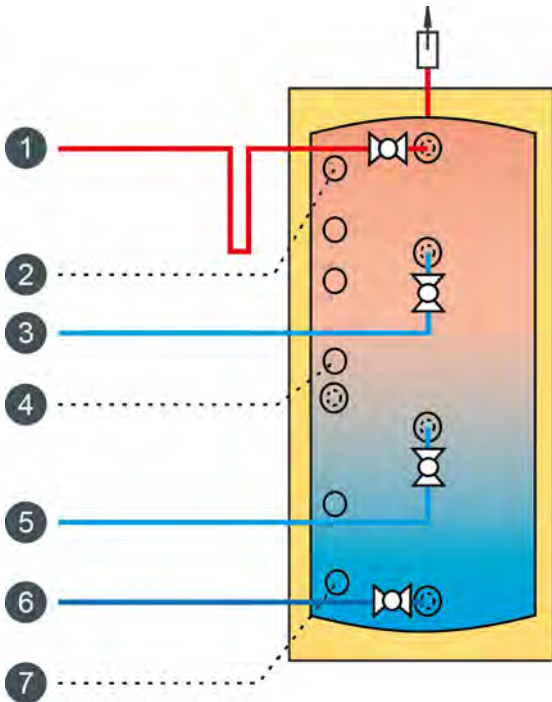

- 1 Boiler flow, heating circuits, hot water tank, oil/gas boiler
- 2 Temperature sensor [Sensor 1 (upper)]
- 3 Oil/gas boiler return
- 4 Temperature sensor [Sensor 2]
- 5 Hot water tank return
- 6 Boiler, heating circuits return
- 7 Temperature sensor [Sensor 3]

i The temperature sensor [Sensor 3] must always be positioned just above the lowest return connection. This is also important for buffers from third parties so that they are not positioned beneath the lowest return connection.

With fresh water module

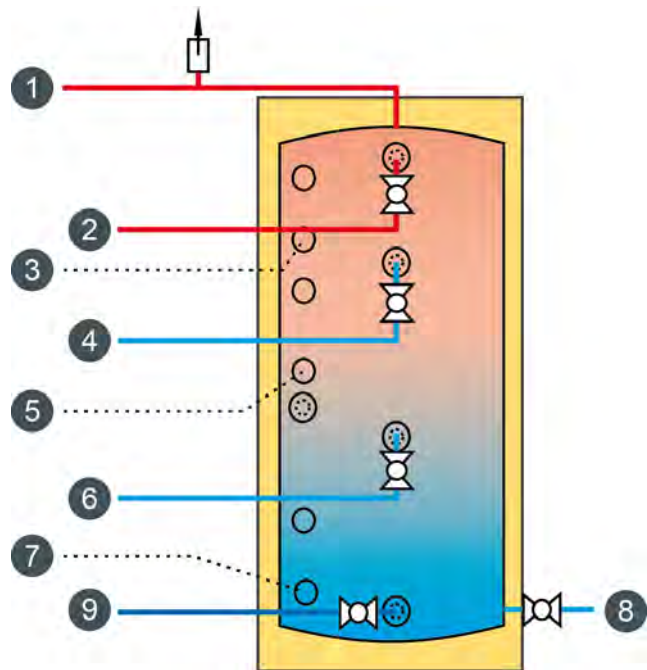

- 1 Fresh water module flow
- 2 Boiler, heating circuits, oil/gas boiler flow
- 3 Temperature sensor [Sensor 1 (upper)]
- 4 Oil/gas boiler return
- 5 Temperature sensor [Sensor 2]
- 6 High-temperature circuits return
- 7 Temperature sensor [Sensor 3]
- 8 Fresh water module return
- 9 Boiler, low-temperature circuit return

With solar exchanger and fresh water module

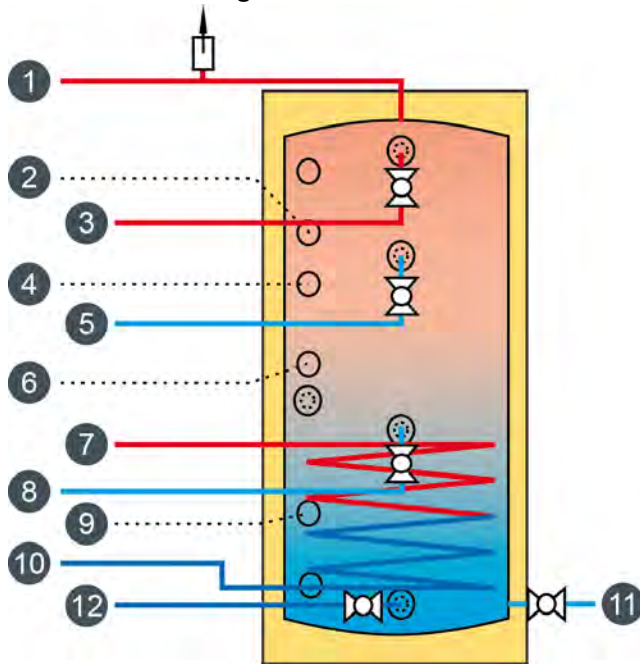

- 1 Fresh water module flow
- 2 Temperature sensor [Sensor 1 (upper)]
- 3 Boiler, heating circuits, oil/gas boiler flow
- 4 Temperature sensor [Sensor 2]
- 5 Oil/gas boiler return
- 6 Temperature sensor [Sensor 3]
- 7 Solar flow
- 8 Boiler, high-temperature circuit return
- 9 Temperature sensor [Sensor 4]
- 10 Solar return
- 11 Fresh water module return
- 12 Low-temperature circuits return

With stratified charging module and fresh water module

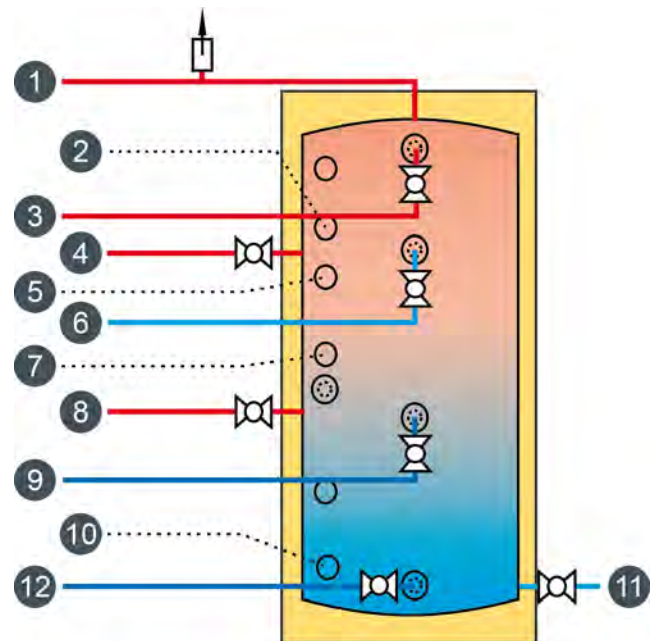

- 1 Fresh water module flow
- 2 Temperature sensor [Sensor 1 (upper)]
- 3 Boiler, heating circuits, oil/gas boiler flow
- 4 Solar flow, top
- 5 Temperature sensor [Sensor 2]
- 6 Oil/gas boiler return
- 7 Temperature sensor [Sensor 3]
- 8 Solar flow, lower
- 9 Boiler, high-temperature circuit return
- 10 Temperature sensor [Sensor 4]
- 11 Fresh water module return, solar
- 12 Low-temperature circuits return

8.3 Connection between multiple buffer storage tanks

Parallel connection

When there are several buffers, parallel connection (top with top and bottom with bottom) is usually the better solution. With a parallel connection, the entire buffer volume is available to installed heat exchangers such as solar heat exchangers or internal water heat exchangers and suspended hot water tanks.

If two buffer storage tanks of different dimensions are connected in parallel, then the flow must be connected to the higher buffer or the lower buffer must be raised so that the upper connection can be horizontal.

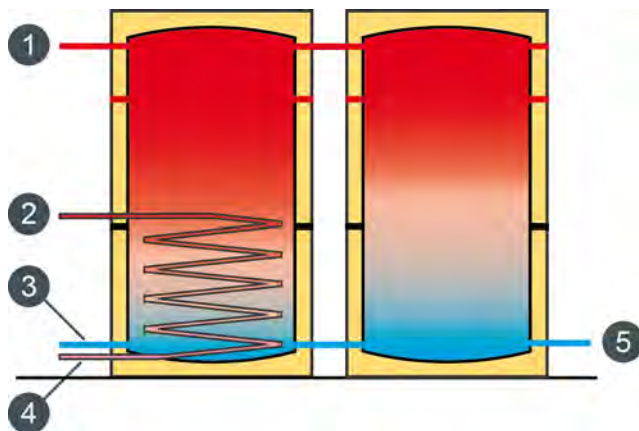

- 1 Flow
- 2 Solar heating system flow
- 3 Return
- 4 Solar heating system return
- 5 Return

Serial connection

A serial connection between two buffers has no advantages over a parallel connection; but it does disadvantages. For example, a suspended hot water tank can get no heat from the second buffer or an internal heat exchanger cannot heat to both buffers. For this reason, with serial buffers one should connect the solar heating system using either heat exchangers in both buffers or (preferred) with an external heat exchanger.

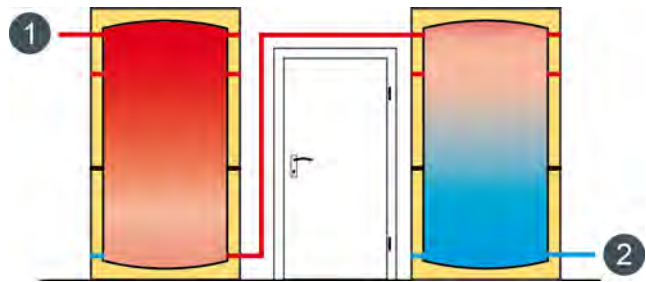

- 1 Flow
- 2 Return

With rare exceptions, the use of the serial connection (buffer 2 top and buffer 1 bottom connected) is limited to overcoming spatial constraints of a particular installation. If passage to a door must be kept free or if there is a long distances between buffers, only a serial connection will be possible

Tichelmann connection for higher outputs

For parallel connection with one-sided connection, the volume of the second buffer is integrated using the thermosiphon principle. The exchange between the two tanks is driven only by gravity and limited by the hydraulic resistance of the junctions. Therefore, a Tichelmann connection is required for medium outputs.

With a 6/4" connection, a maximum of 5500 l/h at 0.25 mws pressure loss is possible (for flow and return connections together). This corresponds to 130 kW at a spread of 20 °C. Therefore, external piping (either symmetric or with Tichelmann connection), is needed for higher outputs.

With more than two tanks, external piping with Tichelmann connection is also needed to fill and drain all tanks uniformly.

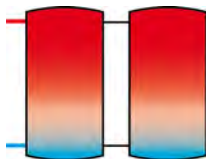
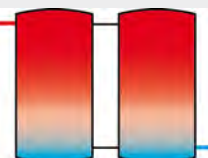
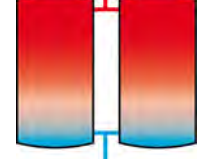
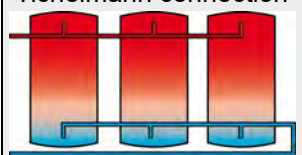
Parallel connection between buffer storage tanks	Buffer connections 5/4" DN 32	Buffer connections 6/4" DN 40
one-sided connection 	< 25 kW boiler output maximum 2 buffers	< 40 kW boiler output maximum 2 buffers
Internal Tichelmann connection 	< 80 kW boiler output maximum 2 buffers	< 130 kW boiler output maximum 2 buffers
Symmetrical connection 	> 80 kW boiler output maximum 2 buffers	> 130 kW boiler output maximum 2 buffers
external piping with Tichelmann connection 	> 80 kW boiler output, and/or more than 2 buffers	> 130 kW boiler output, and/or more than 2 buffers

8.4 Parallel buffer connection

Parallel buffer connection with internal Tichelmann

The basic principle of the internal Tichelmann is diagonal flow; Two buffers are connected together at the top and bottom (= parallel connection). For output up to 90 kW, a connection with DN 32 (ETA buffer connection set) is sufficient, for 30 kW use at least R1" or 28 mm copper. On one tank, the boiler outlet is connected at the top; on the other the boiler return is connected at the bottom. Return lines with greatly differing temperatures should be fed into the buffer storage tank separately. To minimize pipe circulation losses, it is helpful to make the connections with downward siphon loops.

With hot water tank

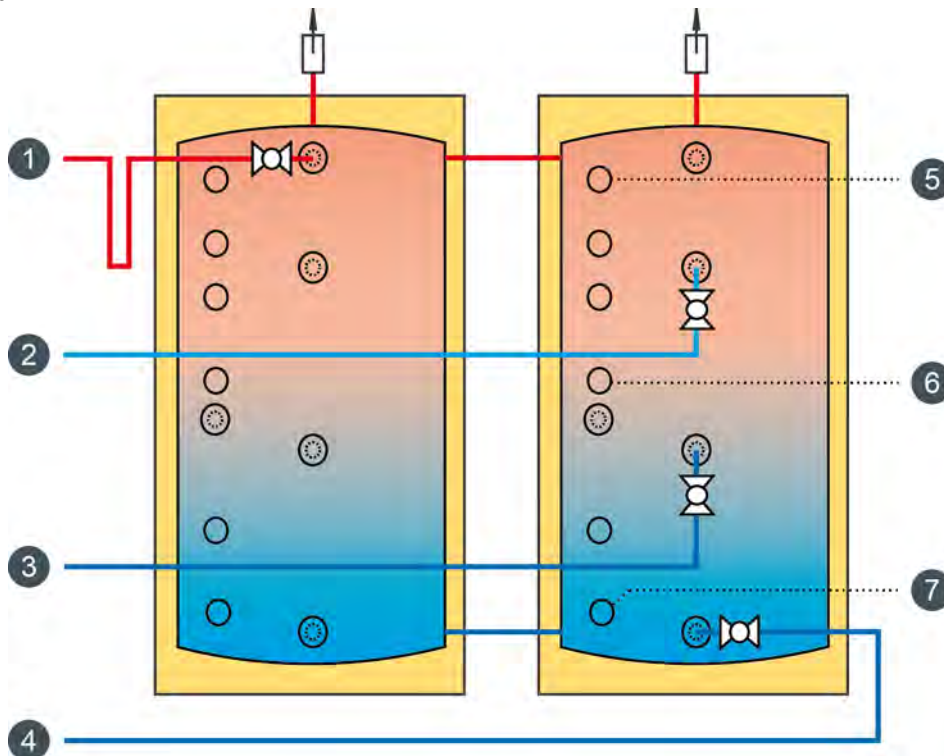

- 1 Boiler flow, heating circuits, hot water tank, oil/gas boiler flow
- 2 Oil/gas boiler return
- 3 Hot water tank return, high-temperature circuit return
- 4 Boiler, low-temperature circuit return
- 5 Temperature sensor [Sensor 1 (upper)]
- 6 Temperature sensor [Sensor 2]
- 7 Temperature sensor [Sensor 3]

With fresh water module and stratified charging module

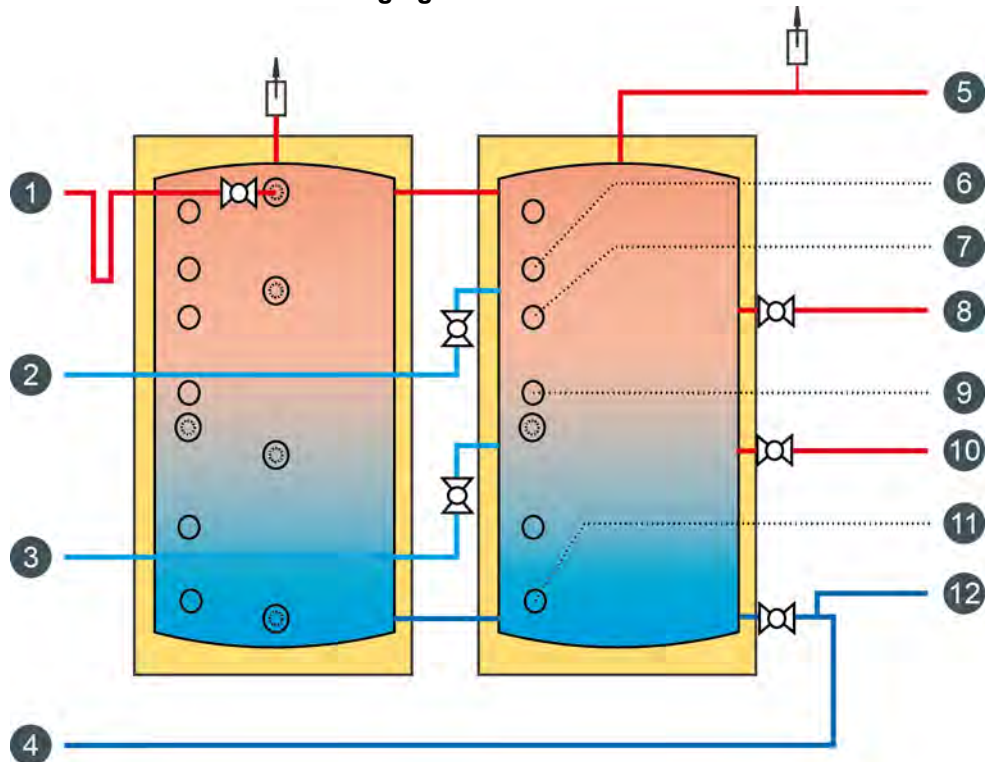

- 1 Boiler, heating circuits, oil/gas boiler flow
- 2 Oil/gas boiler return
- 3 Boiler, high-temperature circuit return
- 4 Low-temperature circuits return
- 5 Fresh water module flow
- 6 Temperature sensor [Sensor 1 (upper)]
- 7 Temperature sensor [Sensor 2]
- 8 Solar flow, top
- 9 Temperature sensor [Sensor 3]
- 10 Solar flow, lower
- 11 Temperature sensor [Sensor 4]
- 12 Fresh water module return, solar



For a sufficient hot water reserve, the release temperatures of the heating circuits must be over 45 °C.

8.5 External Tichelmann

Parallel buffer connection with external Tichelmann

The basic principle of the external Tichelmann is parallel flow through several buffer storage tanks, which is achieved with diagonally opposed connection of the collectors. The last buffer on the flow collector is the first on the return collector. To achieve uniform charging and discharging, the connection pipes should be at least one or two sizes smaller than the collector. There is no output limit for this circuit. To minimize pipe circulation losses, it is helpful to make the connections with downward siphon loops.

 For a small solar heating system, the total volume can be reduced in the summer by locking individual buffers.

With hot water tank or internal water heat exchanger

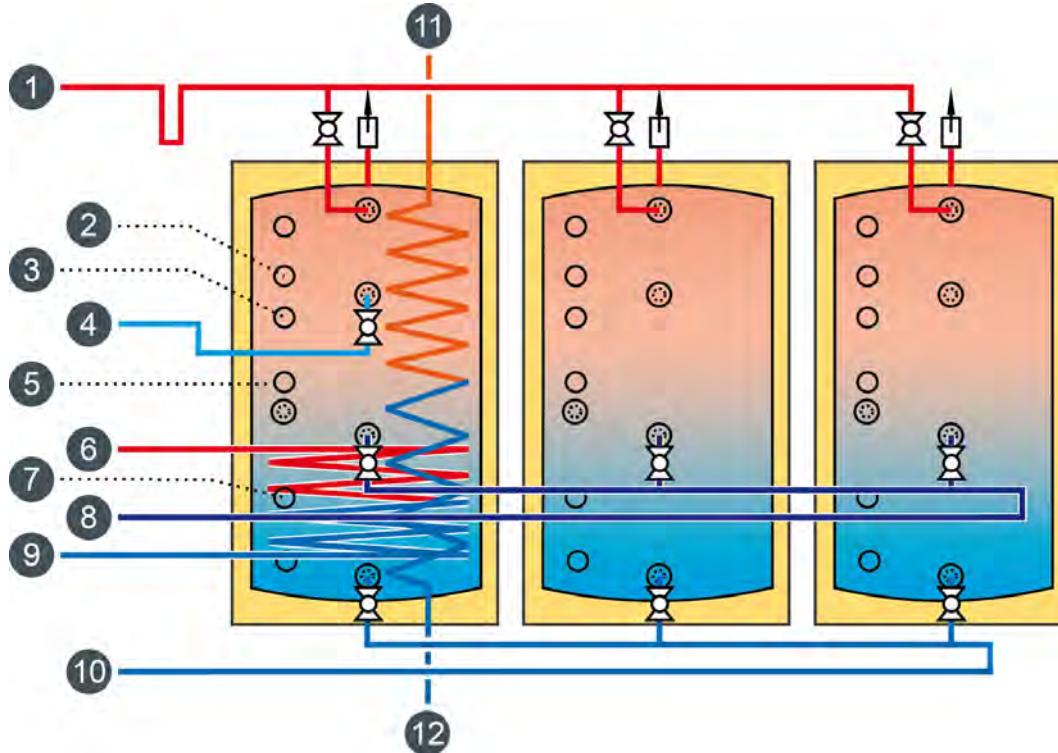

- 1 Boiler, heating circuits, oil/gas boiler flow
- 2 Temperature sensor [Sensor 1 (upper)]
- 3 Temperature sensor [Sensor 2]
- 4 Oil/gas boiler return
- 5 Temperature sensor [Sensor 3]
- 6 Solar flow
- 7 Temperature sensor [Sensor 4]
- 8 Boiler, high-temperature circuit return
- 9 Solar return
- 10 Low-temperature circuits return
- 11 Hot water
- 12 Cold water

maximum total output	Connecting ball valves on buffer	Collector line at least		
30 kW	DN 20	DN 25	R 1"	28 x 1.5
60 kW	DN 25	DN32	R 1¼"	35 x 1.5

maximum total output	Connecting ball valves on buffer	Collector line at least		
		DN	R	Dimensions
90 kW	DN 32	DN 40	R 1½"	42 x 1.5
160 kW	DN 32	DN 50	R 2"	54 x 1.5
300 kW	DN 40	DN 65	R 2½"	76 x 2
450 kW	DN 40	DN 80	R 3"	89 x 2

With fresh water module and stratified charging module

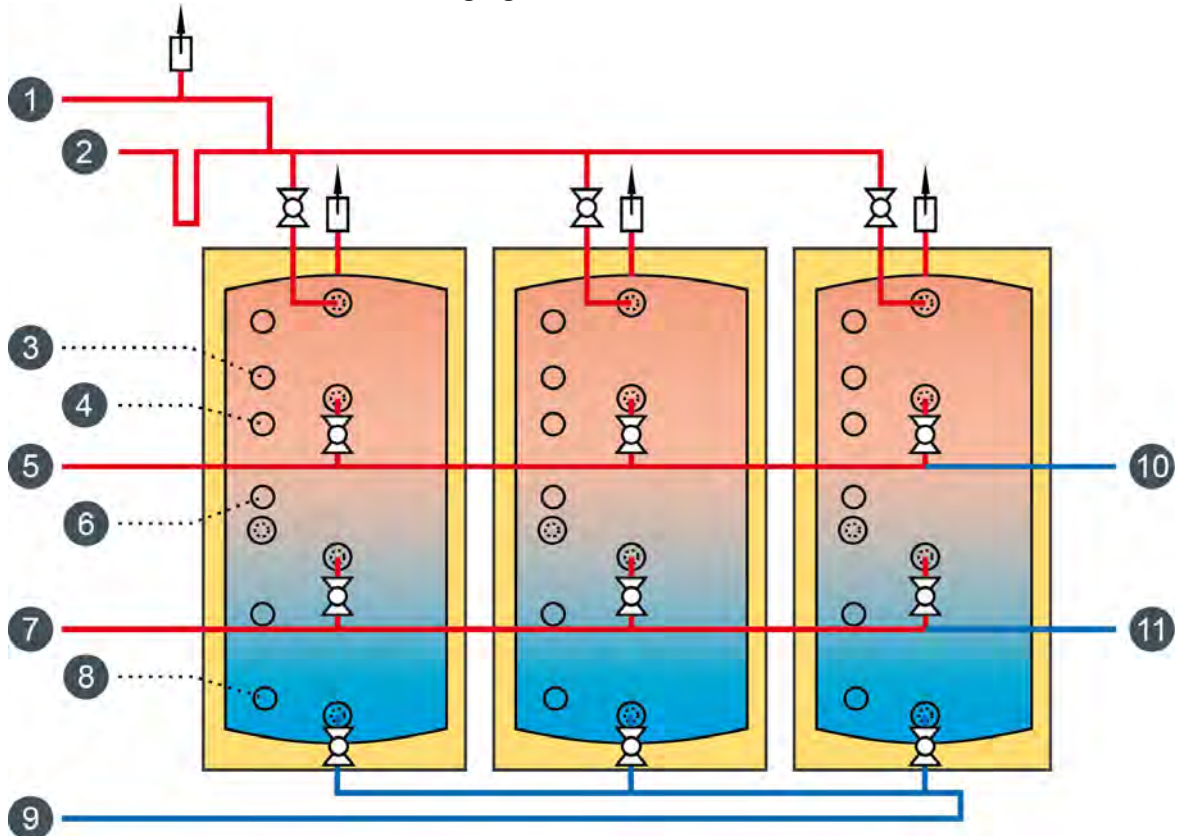

- 1 Fresh water module flow
- 2 Boiler, heating circuits, oil/gas boiler flow
- 3 Temperature sensor [Sensor 1 (upper)]
- 4 Temperature sensor [Sensor 2]
- 5 Solar flow, top
- 6 Temperature sensor [Sensor 3]
- 7 Solar flow, lower
- 8 Temperature sensor [Sensor 4]
- 9 Fresh water module return, solar and low temperature circuits
- 10 Oil/gas boiler return
- 11 Boiler, high-temperature circuit return

8.6 Serial buffer connection

Serial buffer connection

If there are different buffer types, or if not all buffers can be set up in one group, serial connection of the buffers will be necessary. Note that for serial buffer connection, integration of a solar heating system will work adequately only when a fresh water module is used for the hot water supply.

Solar tanks with internal solar exchangers are only of limited effectiveness. Combination tanks with immersed hot water tanks or internal water heat exchangers are unsuitable for a serial buffer connection. To minimize pipe circulation losses, it is helpful to make the connections with downward siphon loops.

With fresh water module

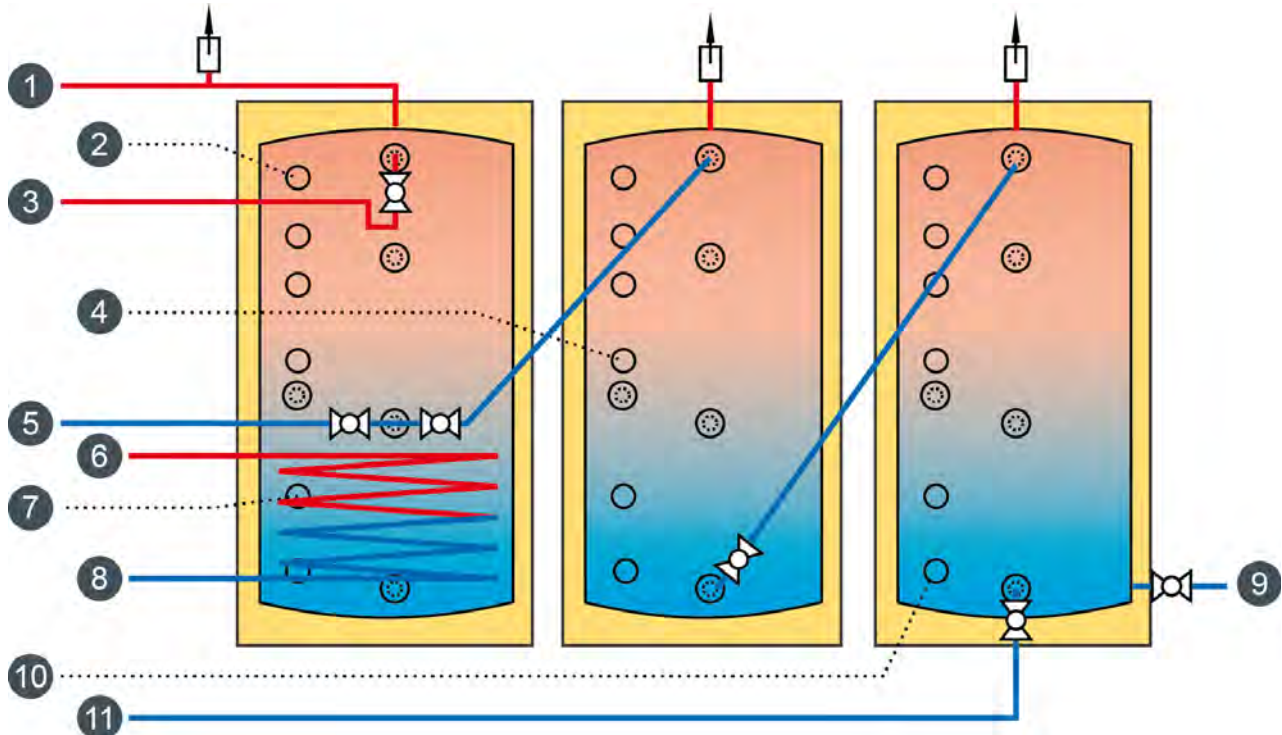

- 1 Fresh water module flow
- 2 Temperature sensor [Sensor 1 (upper)]
- 3 Boiler, heating circuits, oil/gas boiler flow
- 4 Temperature sensor [Sensor 2]
- 5 Oil/gas boiler return
- 6 Solar flow
- 7 Temperature sensor [Sensor 3]
- 8 Solar return
- 9 Fresh water module return
- 10 Temperature sensor [Sensor 4]
- 11 Boiler and heating circuits return

maximum total output	Number of buffers	Connecting line, minimum		
30 kW	4	DN 25	R 1"	28 x 1.5
50 kW	4	DN32	R 1¼"	35 x 1.5
65 kW	2	DN32	R1¼"	35 x 1.5
80 kW	4	DN 40	R1½"	42 x 1.5

maximum total output	Number of buffers	Connecting line, minimum		
100 kW	2	DN 40	R1½"	42 x 1.5
140 kW	4	DN 50	R2"	54 x 1.5
170 kW	2	DN 50	R2"	54 x 1.5

With fresh water module and stratified charging module

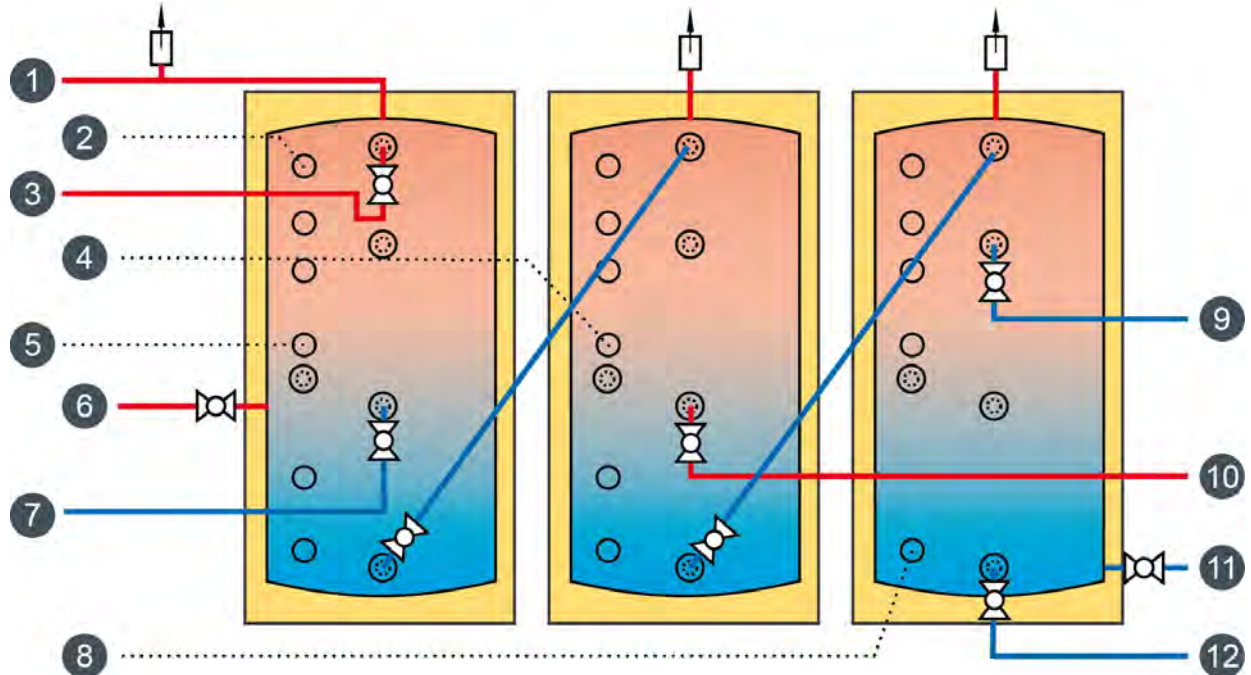

- 1 Fresh water module flow
- 2 Temperature sensor [Sensor 1 (upper)]
- 3 Boiler, heating circuits, oil/gas boiler flow
- 4 Temperature sensor [Sensor 2]
- 5 Temperature sensor [Sensor 3]
- 6 Solar flow, top
- 7 Oil/gas boiler return
- 8 Temperature sensor [Sensor 4]
- 9 High-temperature circuits return
- 10 Solar flow, lower
- 11 Fresh water module and solar return
- 12 Boiler and low-temperature circuit return

9 Installation

Assembly and installation only by qualified specialist personnel

 The assembly and installation may be performed by specialist personnel with the corresponding qualifications only.

Technical illustrations

The technical illustrations in this documentation portray a wood chip boiler with the fuel conveying system on the left side.

The illustrations are representative for a boiler with the fuel conveying system on the right side.

9.1 Placement of the boiler

Transporting the boiler into the boiler room

Transport the boiler into the boiler room. The required clearances for installation and maintenance must be maintained; see chapter 2 "[Technical data](#)".

Lifting lug for transporting the boiler

Lifting lugs are located on the top side for lifting the boiler. The weight of the boiler is approx. 2000 kg.

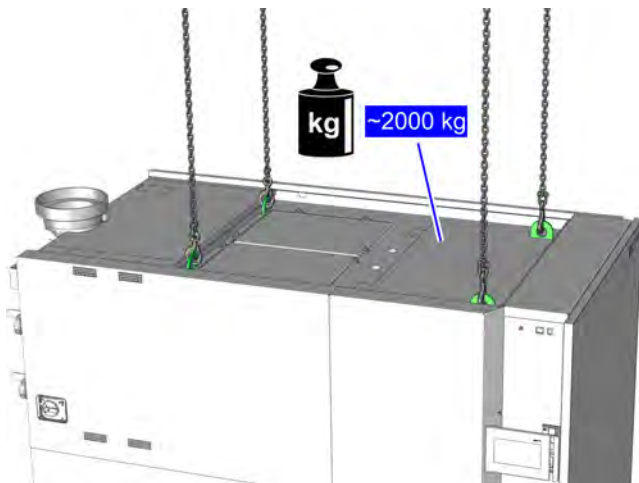

An optional sound-insulation set is available

 An optional sound-insulation set is available for the boiler. If you use this, insert the sound-insulation strips longitudinally under the boiler's base frame and also under the stoker's levelling screws.

9.2 Mount flue gas connection

Mounting the flue gas connection

Remove the cover from the top of the boiler.

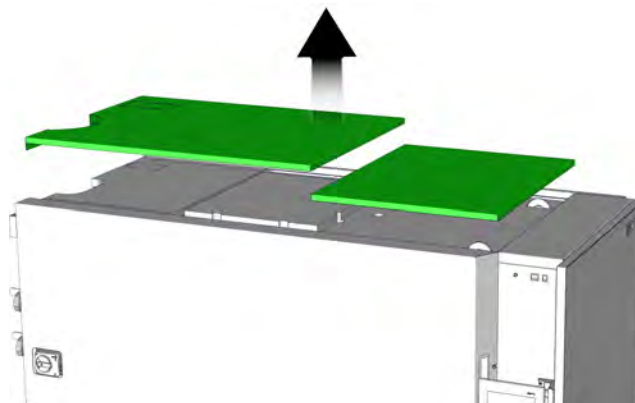

Fig. 9-1: Cover

Check the flue gas connection seal for damage. Attach the flue gas connection to the boiler with the nuts. Tighten the nuts alternately and evenly.

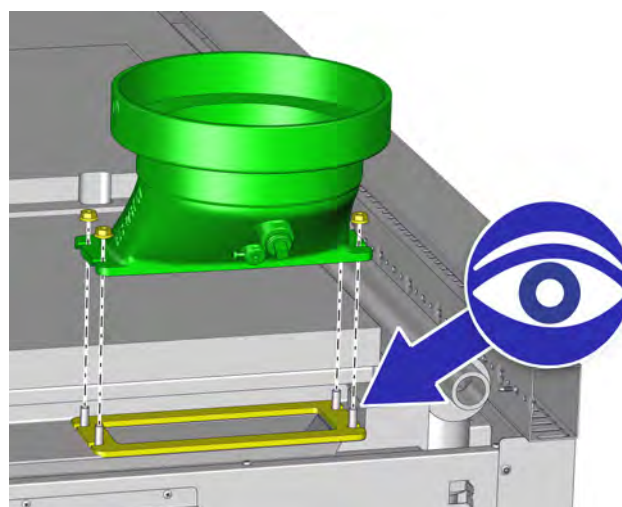

Fig. 9-2: Flue gas connection

Mount the flue gas temperature sensor and secure it with the screw. Only hand-tighten the screws so as not to damage the temperature sensor.

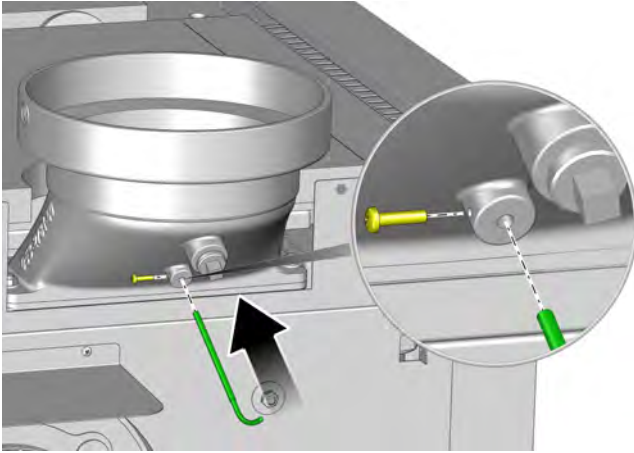

Fig. 9-3: Flue gas temperature sensor

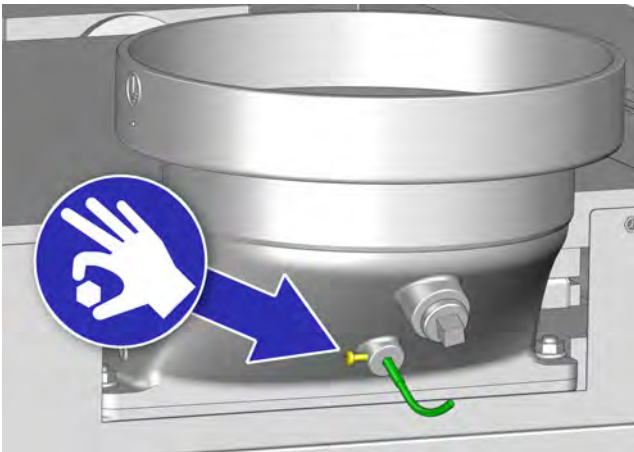

Fig. 9-4: Screw

9.3 Mounting the air valve for flue gas recirculation (optional)

Installing the actuator

Insert the adapter into the actuator. Ensure the correct position, the slit must be 90° offset to the screw on the actuator.

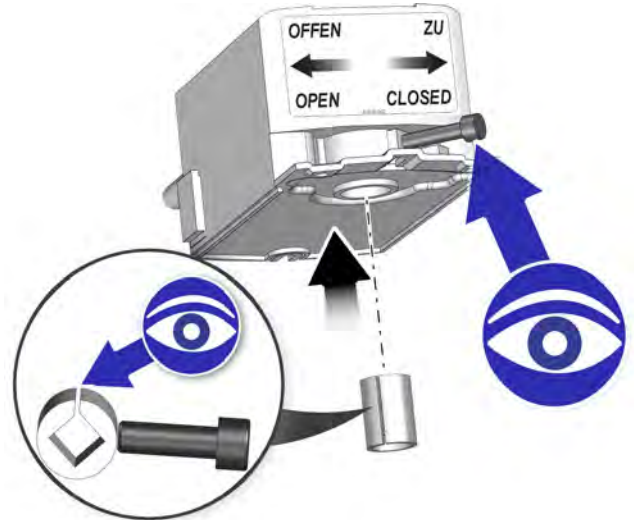

Fig. 9-5: Adapter

Turn the actuator in the closed position (see sticker). Also turn the air valve shaft to the fully closed position. Place the air valve on the shaft and fix it in the actuator with the screw.

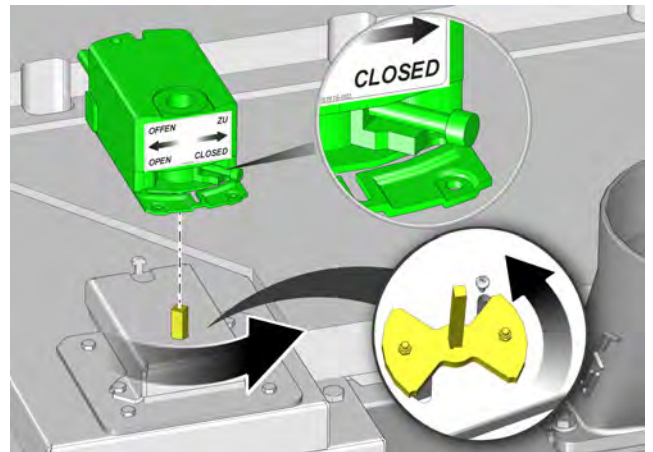

Fig. 9-6: Actuator

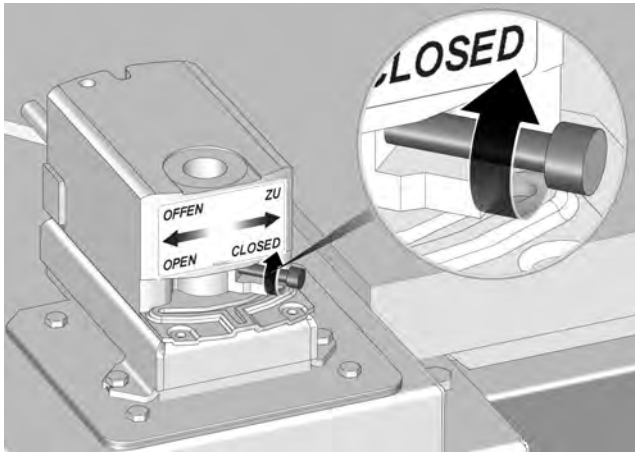

Fig. 9-7: Screw

Then connect the actuator to the line already laid (on the top of the boiler).

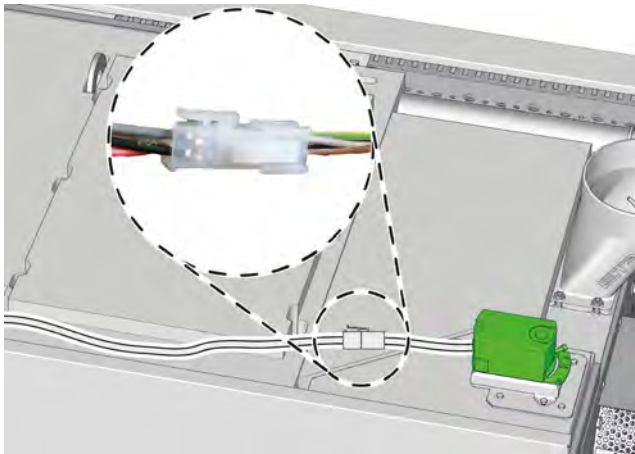

Fig. 9-8: Electrically connecting the actuator

9.4 Removing panels

Dismantling the side panels

Remove the side panels from each side of the boiler on which the stoker will later be mounted.

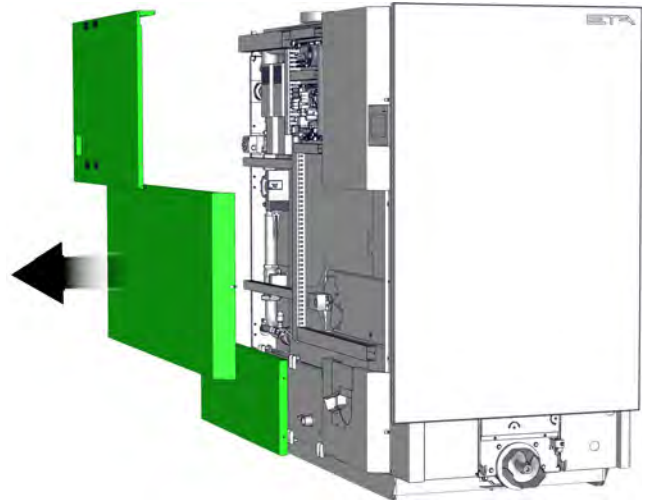

Fig. 9-9: Side panels

9.5 Stoker

Installing the stoker on the boiler

Inspect the affixed seal to ensure it is in good order; replace it if necessary.

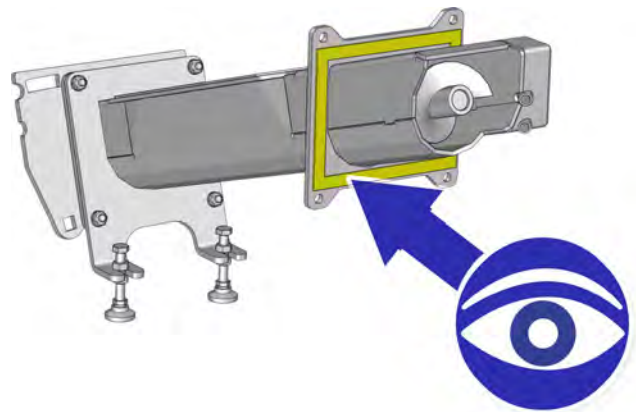
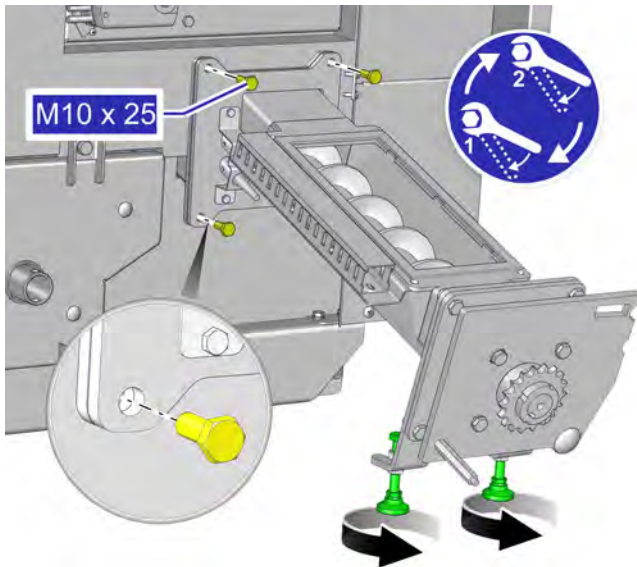

Fig. 9-10: Seal

Mount the levelling screws on the underside of the stoker. Fasten the stoker to the boiler. Tighten the screws alternately and evenly.



Adjust the stoker height with the levelling screws so that the stoker is supported by them.

Installing the rotary valve

Inspect the affixed seal to ensure it is in good order; replace it if necessary.

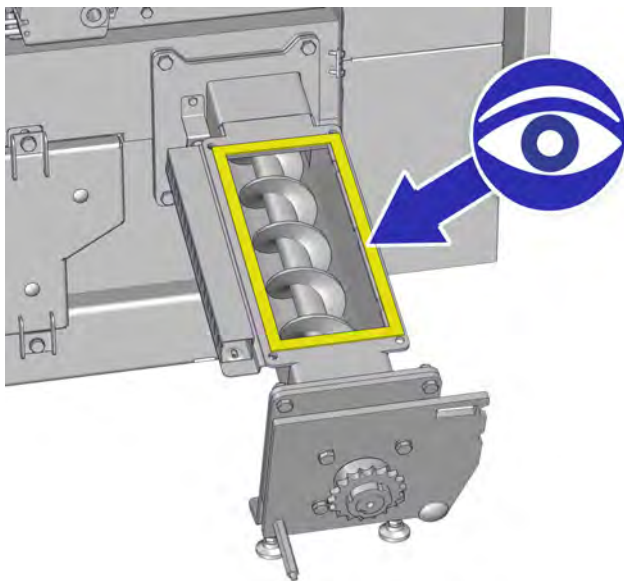

Fig. 9-11: Seal

Fasten the rotary valve on the stoker. Tighten the screws alternately and evenly.

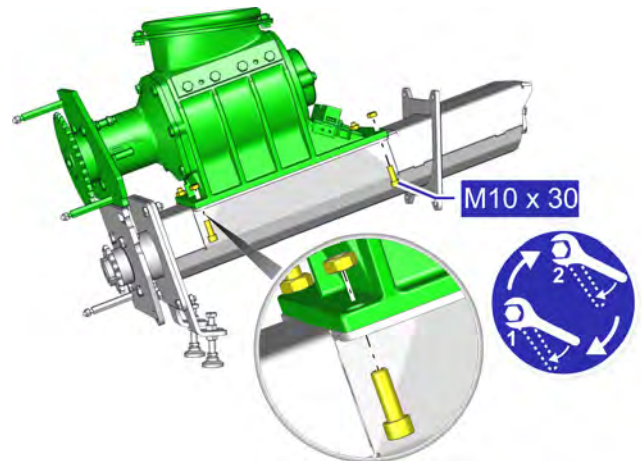

Fig. 9-12: Rotary valve

Attaching the stoker drive

First insert the lowest screw on the stoker and only hand-tighten the nut.

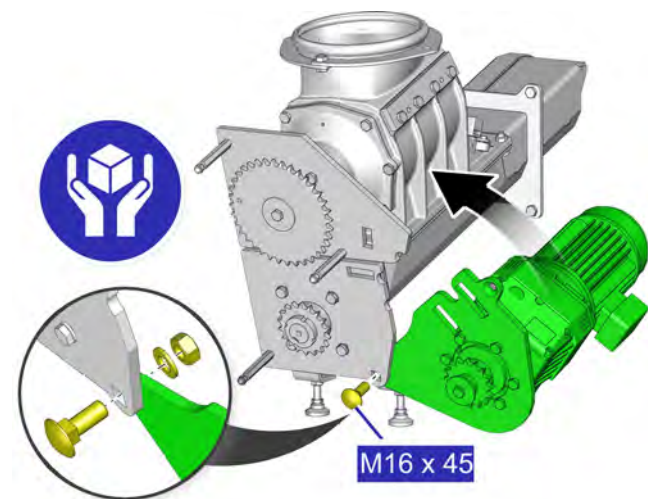
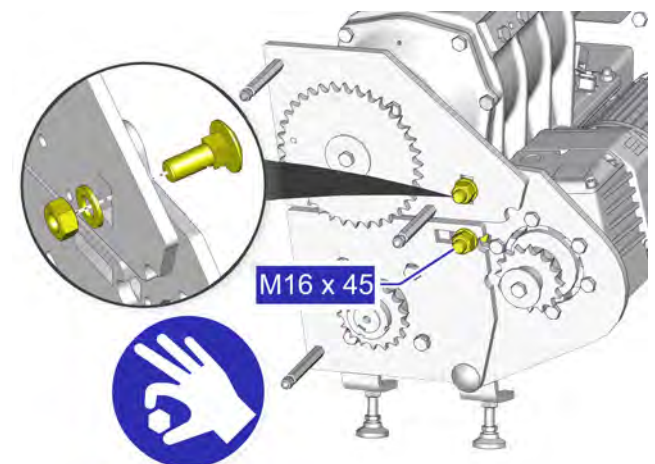

Fig. 9-13: Drive

Turn the drive upwards and hand-tighten it with two screws and nuts.



Loosen the turnbuckle and attach it to the stoker.

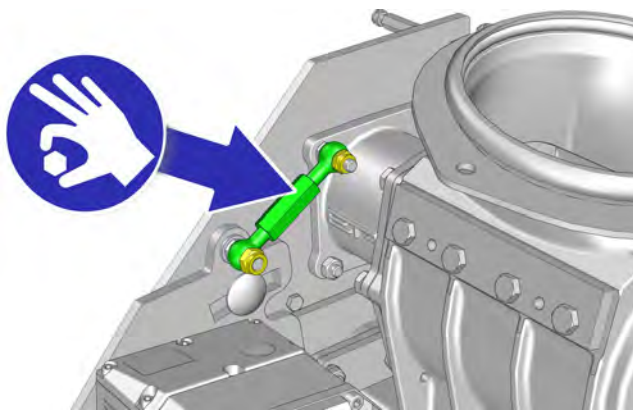

Fig. 9-14: Turnbuckle

9.6 Assembling the conveyor

Technical illustration

The following description shows the installation of a floor agitator with leaf springs. The illustrations also apply equally to an agitator with articulated arm and double articulated arm.

Attaching the open trough

i The conveyor screws are already in the troughs from factory.

The conveyor screw in the open trough has narrower windings in the open area than in the closed area. Check whether the conveyor screw is correctly inserted in the open trough.

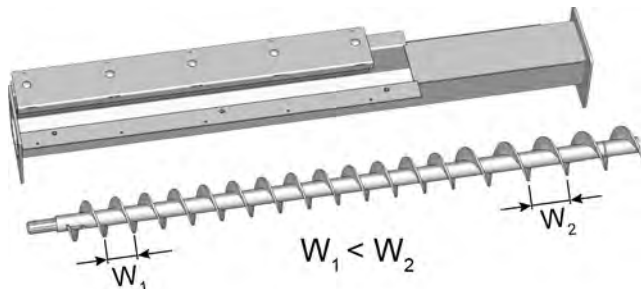

Fig. 9-15: Conveyor screw for the open trough

Affix the seals to the flange.

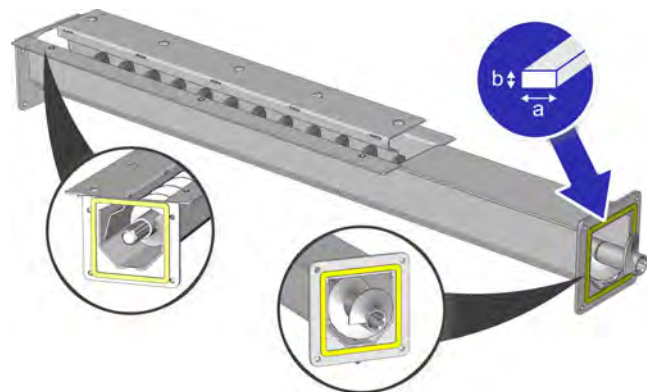

Fig. 9-16: Seals

Grease the drive stub of the conveyor screw with Stauffer grease.

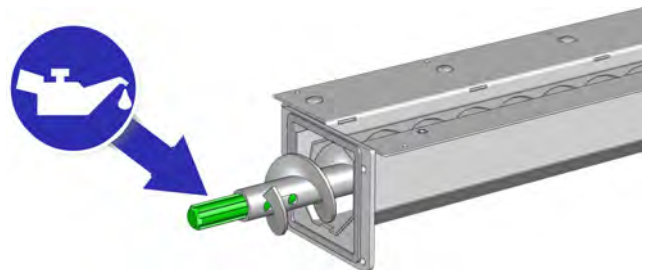

Fig. 9-17: Drive stub

i The grease protects the connection against moisture and thus prevents rust. Therefore the connection can easily be detached later for necessary repair, for example.

Attach the open trough to the gearbox.

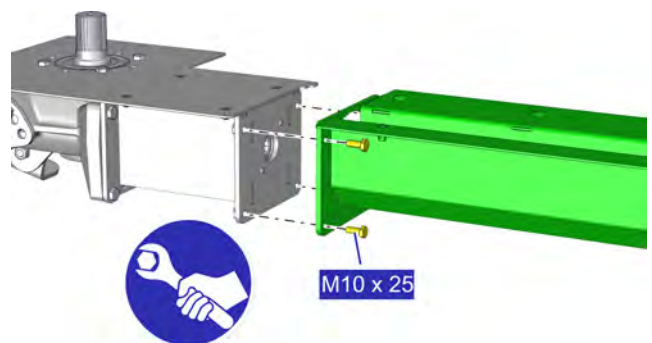

Fig. 9-18: Gearbox

Carefully insert the conveyor screw into the gearbox.

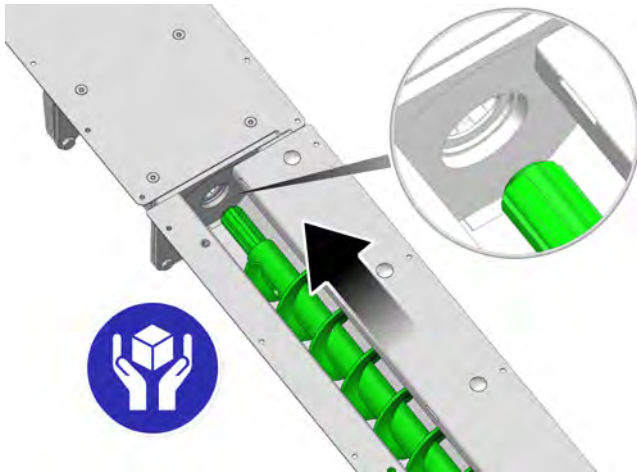

Fig. 9-19: Conveyor screw

Thread the open trough through the wall opening from the storeroom into the boiler room. Place a square timber under the trough as a spacer in the wall opening. The closed part of the trough must be located in the wall opening.

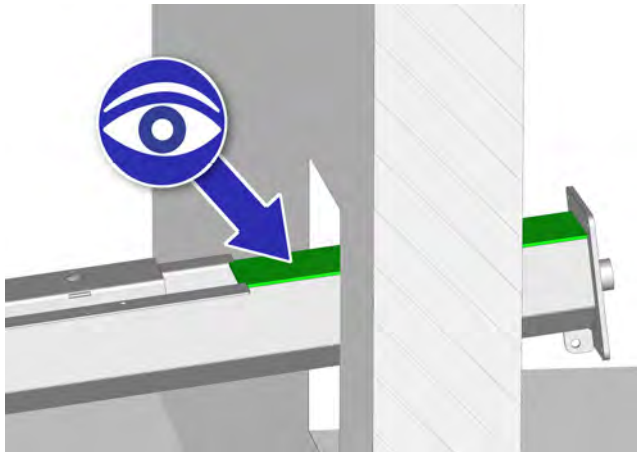

Fig. 9-20: Closed part of the trough

Mount the support stand on the trough.

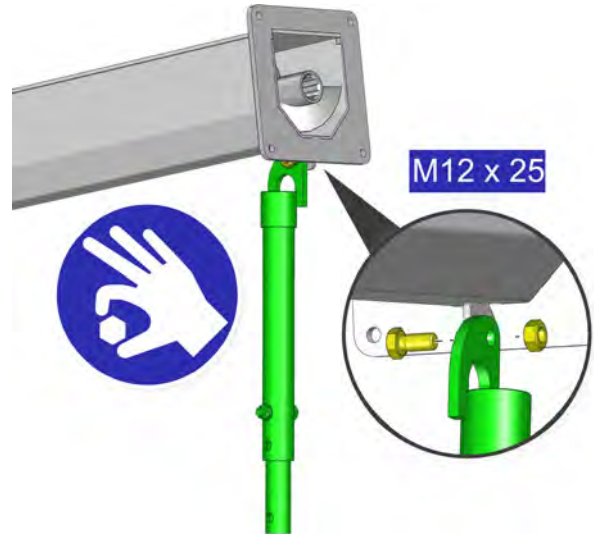
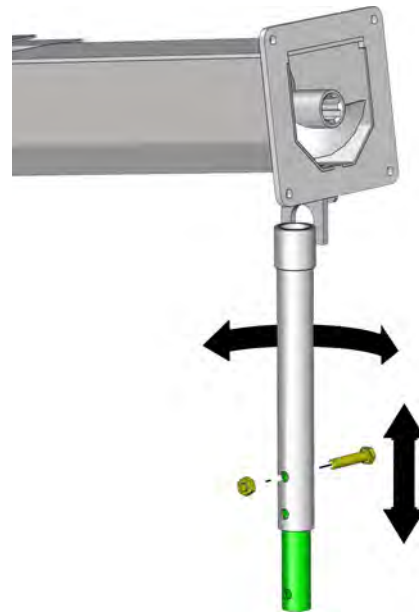

Fig. 9-21: Support stand

Adjust the height of the support stand. Rotate the support stand for fine adjustment.



Attach closed troughs

Grease the drive stub of the conveyor screw with Stauffer grease and connect it with the existing conveyor screw.

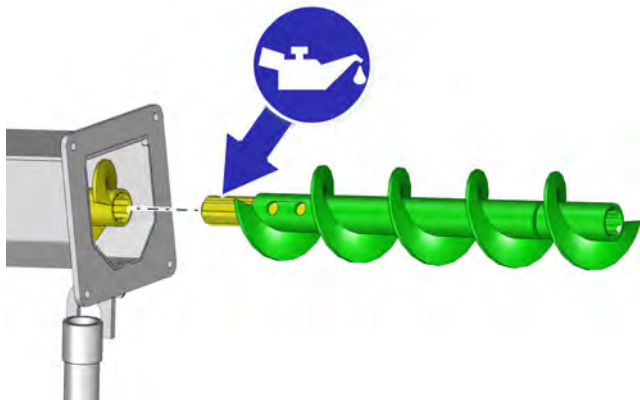

i Make sure that the winding is continuous.

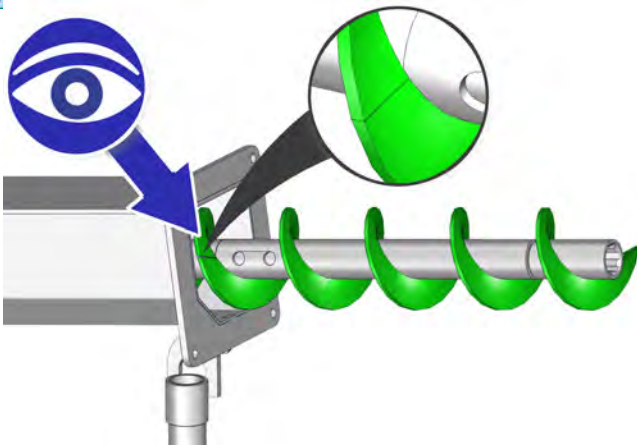

Mount the closed trough on the open trough.

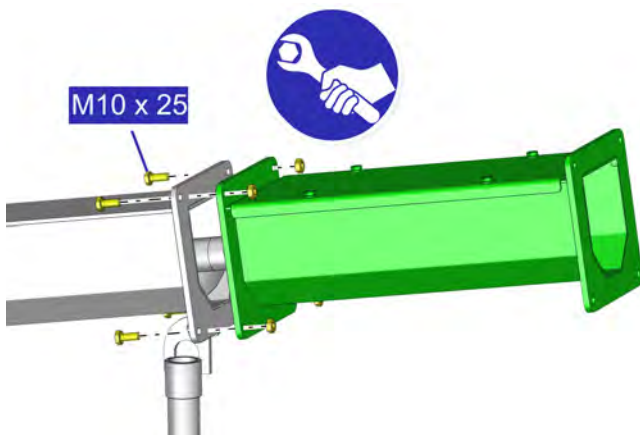

Fig. 9-22: Closed trough

Attach a seal to the flange. Repeat these steps if several troughs are to be installed.

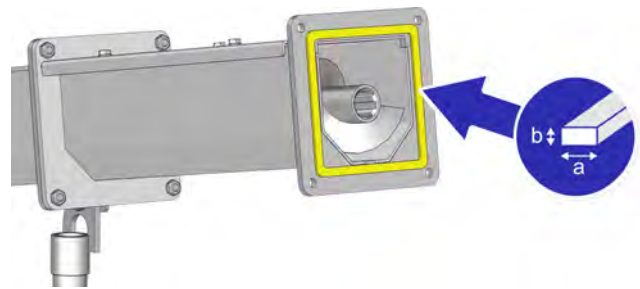

Fig. 9-23: Seal

Installing the drop chute

Grease both drive stubs of the conveyor screw with Stauffer grease and connect them. Make sure that the winding is continuous.

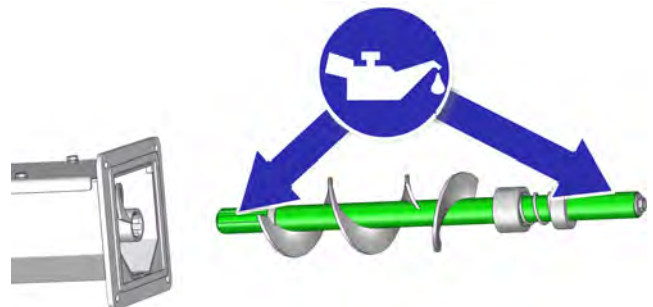
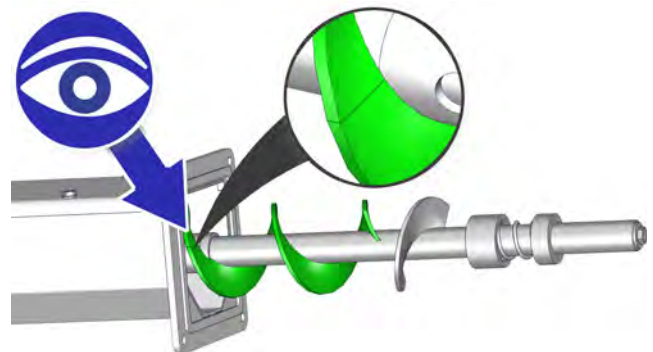

Fig. 9-24: Start screw



Install the drop chute on the trough.

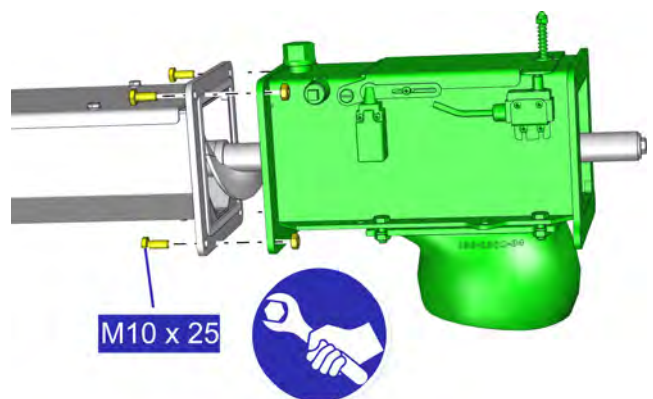

Fig. 9-25: Drop chute

Attach a seal to the flange.

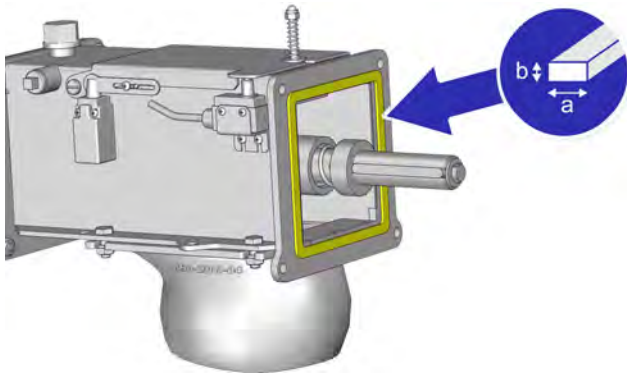
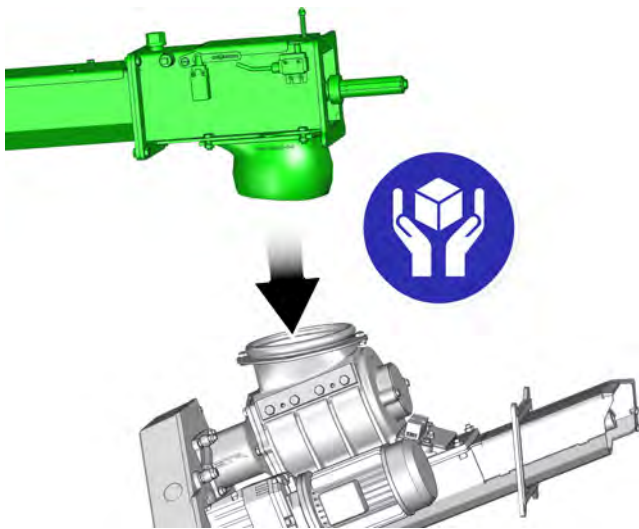

Fig. 9-26: Seal

Lift the discharge and carefully insert the ball joint connection into the opening of the rotary valve.



i Ensure that the ball joint connection lies completely in the rotary valve and that it closes.

Fasten the ball joint connection on the drop chute with the threaded rods. Only hand-tighten the nuts initially.

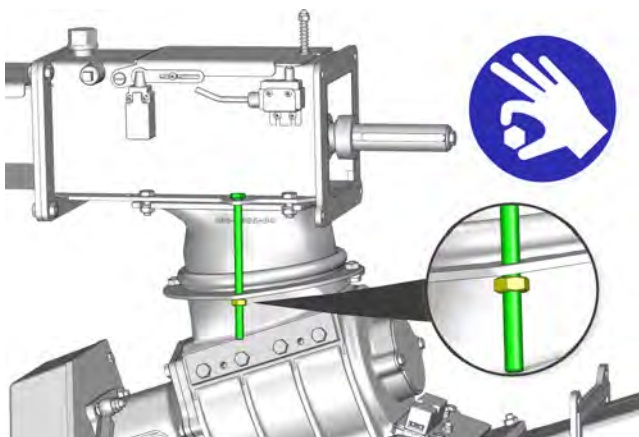

Installing the discharge drive

Align the screw conveyor with the drive using the feather key.

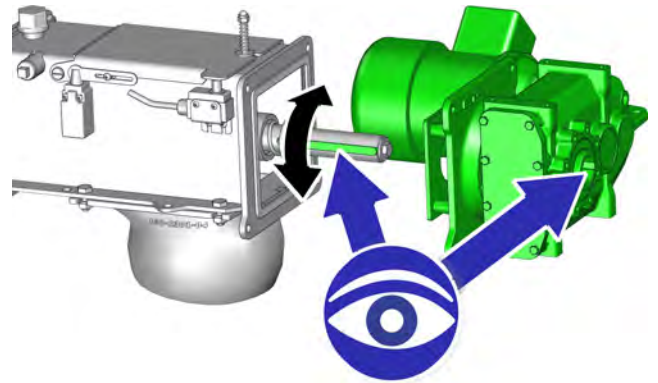

Fig. 9-27: Drive

Slide the drive onto the screw conveyor and fasten it. Tighten the screws alternately and evenly.

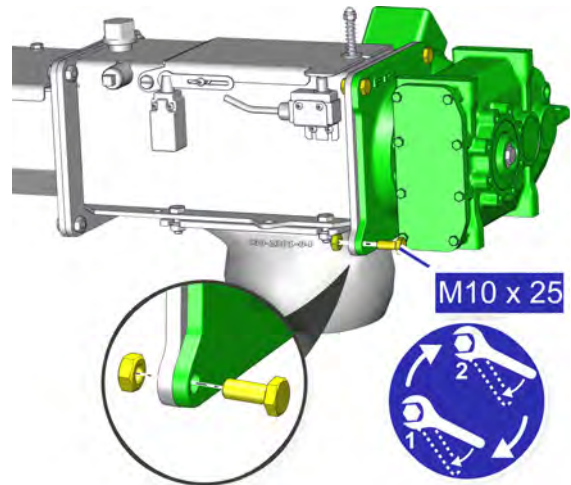

Fig. 9-28: Screws

Installing the bleed screw

The gearbox is already filled with oil from factory and closed with a plug screw. Remove this plug screw and keep it with the gearbox in event of a return, so that oil does not run out.

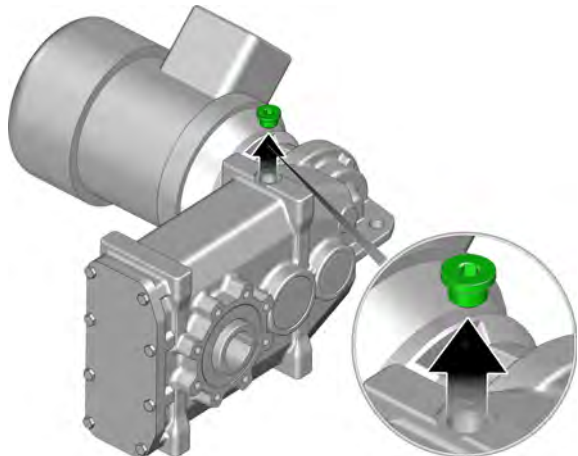

Fig. 9-29: Plug screw

Install the bleed screw in place of the plug screw.

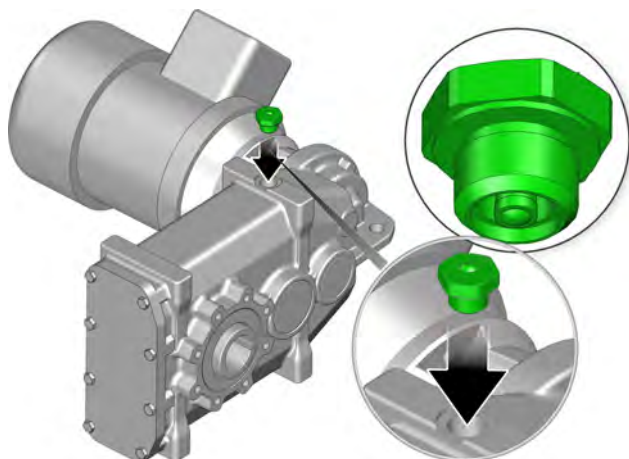

Fig. 9-30: Bleed screw

Mounting the spring arms

Grease the drive stub with Stauffer grease. Carefully place the rotary plate on the drive stub and secure it with the screw and washer.

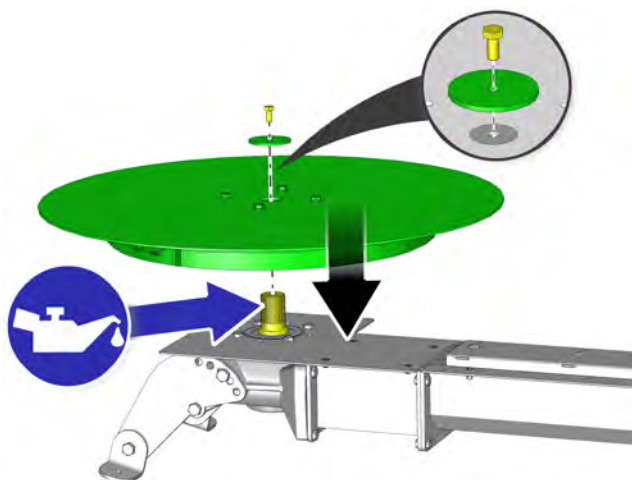

Fig. 9-31: Rotary plate

Mount the spring arms on the opposite side of the rotary plate. The rotary plate always rotates anti-clockwise. Note the correct alignment of the claws on the spring arms, see figure below.

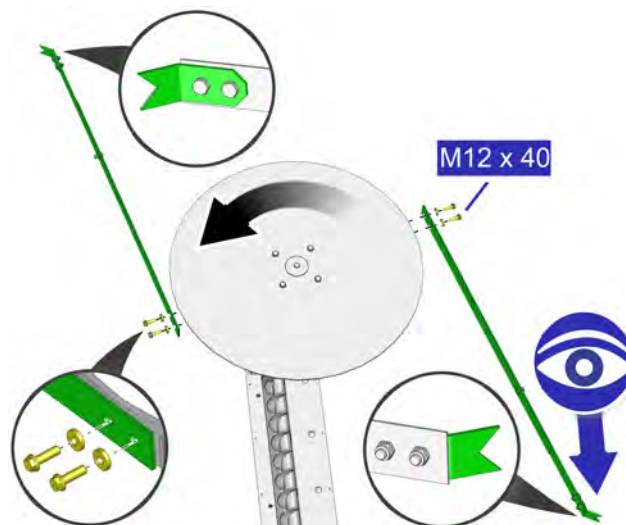

Fig. 9-32: Spring arms

Adjusting the spring arms

Check the alignment of all spring arms. They must be aligned parallel to the trough and may not touch either the trough nor the rotary plate. Turn the rotary plate manually and check all spring arms.

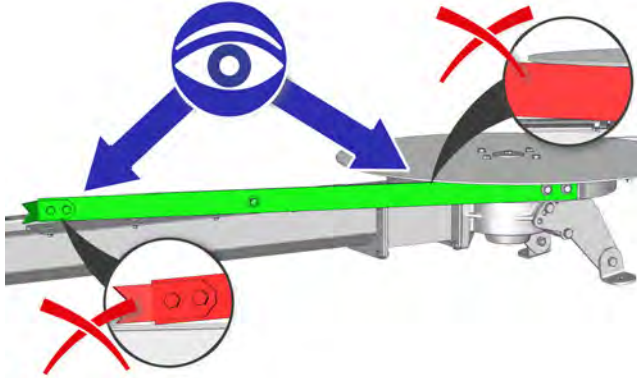

Fig. 9-33: Checking the alignment

To adjust, loosen the screws on the rotary plate and correct the alignment of the spring arm.

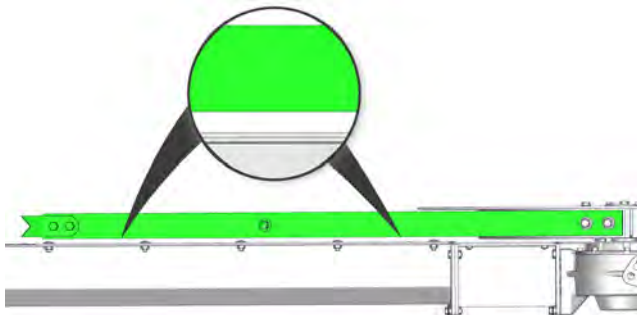

Fig. 9-34: Spring arm parallel to trough

⚠ CAUTION!

Damage caused by incorrect trough clearance

If the trough distance is too small, the spring arms will brush against the trough, causing noise and damage.

If the trough clearance is too large, the spring arms can no longer completely retract under the cover plate and are damaged.

- Set all spring arms parallel to the trough.

⚠ CAUTION!

Damage caused by fixed spring arms

If multi-part spring arms are fixed, the elements cannot move when they meet resistance. The spring arms thus cannot compensate for such stresses and break off.

- The spring arms are pre-assembled at the factory. Do not tighten or loosen the connecting screws.



Fig. 9-35: Screws

Setting the inclination

Position a pallet jack or a wooden block under the gearbox to keep the gearbox from falling down. Then adjust the inclination of the discharge. The support stand must rest completely on the ground for later attachment.



Fig. 9-36: Adjusting the inclination

Checking the wall distance

Turn the floor agitator by hand and check the clearance from the storeroom walls. Then align the floor agitator in the centre of the storeroom, so that the wall clearance is uniform.

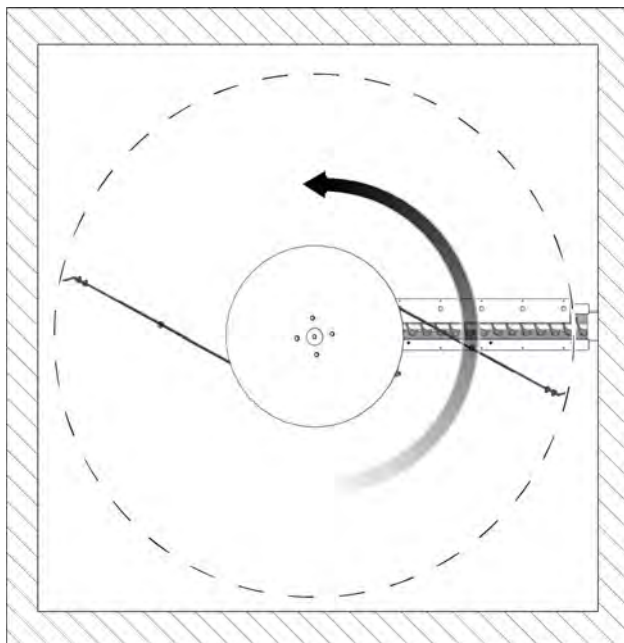

Finally, turn the floor agitator one full turn and check the clearances again.

i If the spring arms scrape the walls, the walls must be protected with boards.

Checking the floor distance

Turn the discharge by hand until the end of the leaf spring reaches the lowest point in the storeroom. The clearance between the spring arm and the floor must be a minimum of 10 mm.

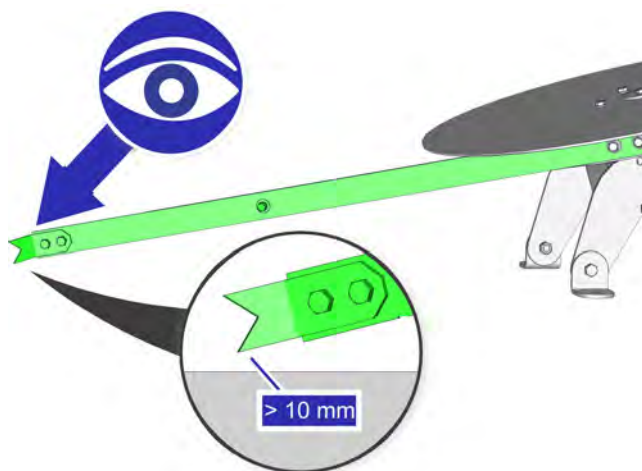

Fig. 9-37: Floor distance

i If you install a slanted floor, also take the thickness of the boards into account.

Check if the clearance is the same for all other spring arms and adjust them if necessary.

Adjust the height of the support stand so that the trough is not sagging or overhanging.

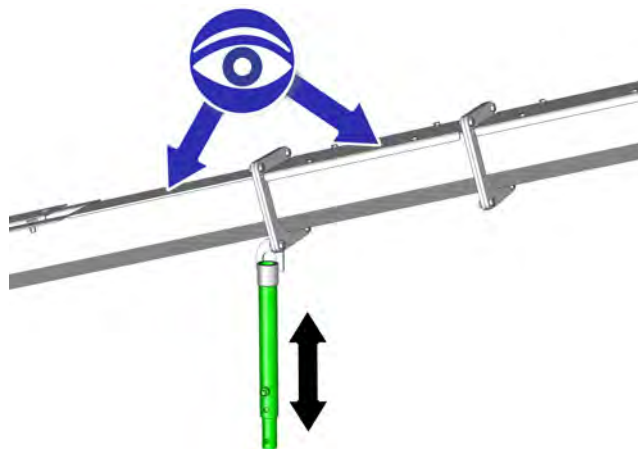

Fig. 9-38: Adjusting the support stand

i Fill the wall opening with mineral wool and plaster the wall.

Fixing the support stand to the floor

Fix the support stand to the floor with suitable screws.

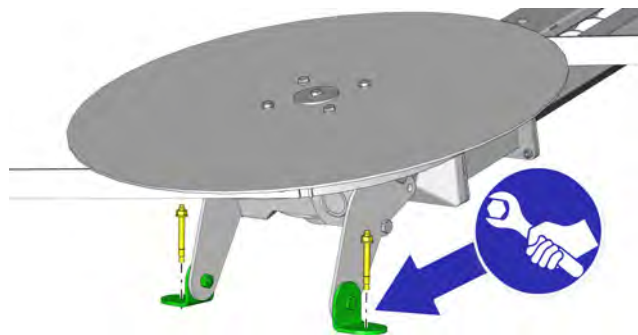

Fig. 9-39: Support stands

Tightening the screws

Tighten all the screws alternately and evenly.

9.7 Installing the drive chain

Fixing the ball joint connection

Secure the ball joint connection with the two threaded rods and nuts. Tighten the nuts alternately and evenly.

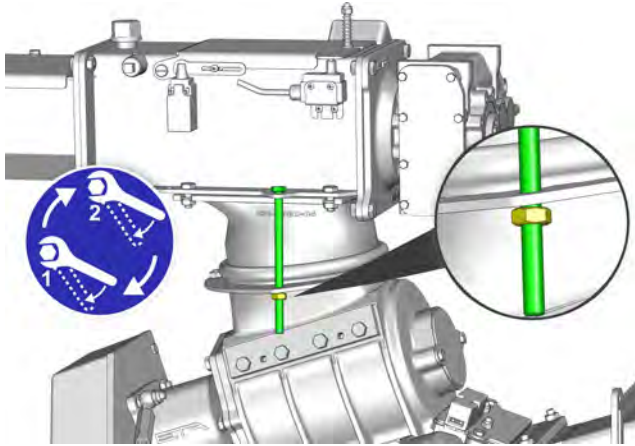

Fig. 9-40: Ball joint

Installing the drive chain

Place the drive chain over the gears and lock the chain with the chain lock. Check the chain tension afterwards. The chain may sag by 1 - 2 cm without effort.

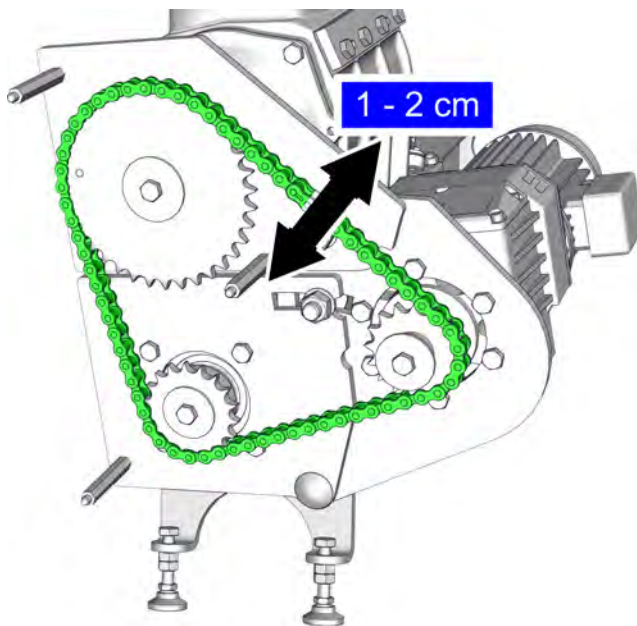

Fig. 9-41: Stoker drive chain

Adjust the chain tension with the turnbuckle.

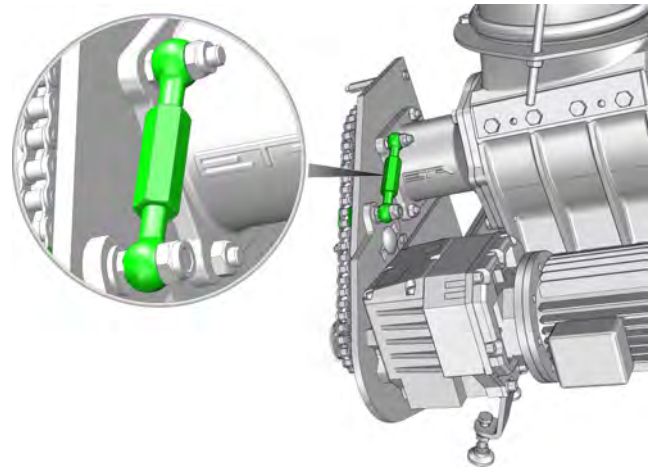

Fig. 9-42: Turnbuckle

Then tighten the three M16 x 45 screws. Check the chain tension again afterwards.

Attaching the cover

Install the cover.

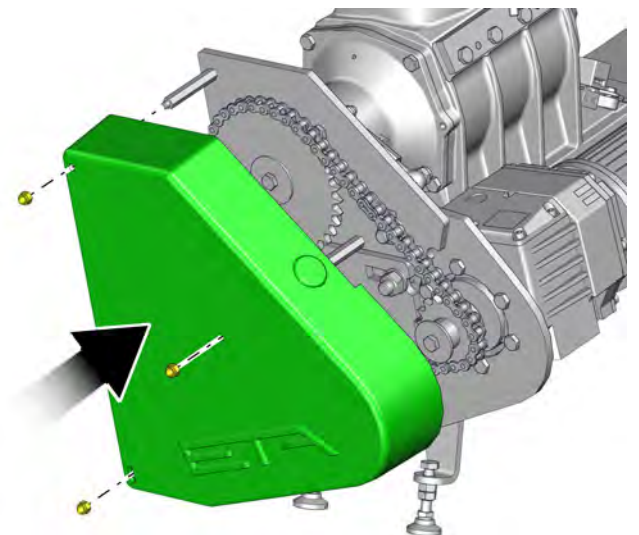



Fig. 9-43: Cover

9.8 Fuel store

Installing safety devices

Install the required safety devices for the fuel discharge; see chapter [6 "Safety"](#).

Covering the wall opening

 Pad the discharge trough in the wall opening with at least 30 mm of mineral wool to reduce possible noise pollution.

To ensure fire safety, cover both sides of the wall opening with fire-resistant plasterboard (sheetrock, for example).

Locking the fuel store, posting a warning sign

The entrance to the fuel store must be lockable to prevent unauthorised access. The supplied warning sign (from the delivery scope) for the fuel store must be installed outside in an easily visible location.



i A special danger in the fuel store is the formation of a hollow dome above the agitator. Children playing on the pile of wood chips, or careless adults, could fall in and get buried or entangled in the discharge screw.

9.9 Align boiler horizontally

Aligning the boiler horizontally

Check the horizontal alignment of the boiler covers and adjust them by placing metal plates underneath.

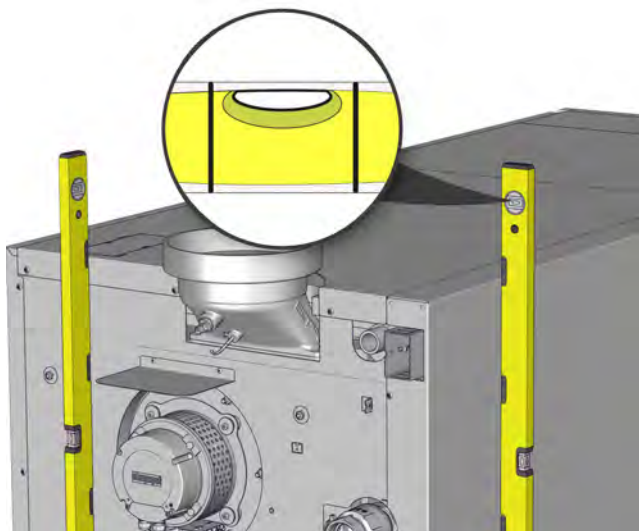

Fig. 9-44: Checking the alignment

i The horizontal alignment of the boiler is important because the electrode in the precipitator must be an equal distance away from the inner walls on all sides. Even if the boiler is not equipped with a precipitator, it must still be horizontally aligned because the precipitator may be retrofitted at a later time.

Horizontal alignment is also important for the separate ventilation connection. For this reason, never align the boiler to be "rising" or "falling".

9.10 Ash box

Mounting the ash box

The assembly of the ash box depends on the installation side of the stoker. The installation side is viewed from the insulation door towards the rear of the boiler. Left means that the stoker is installed on the left side of the boiler.

1. Stoker on the left side of the boiler:



2. Attach the seal and mount the ash duct to the ash box. Note the alignment of the ash duct, see graphic. Tighten the screws alternately and evenly.

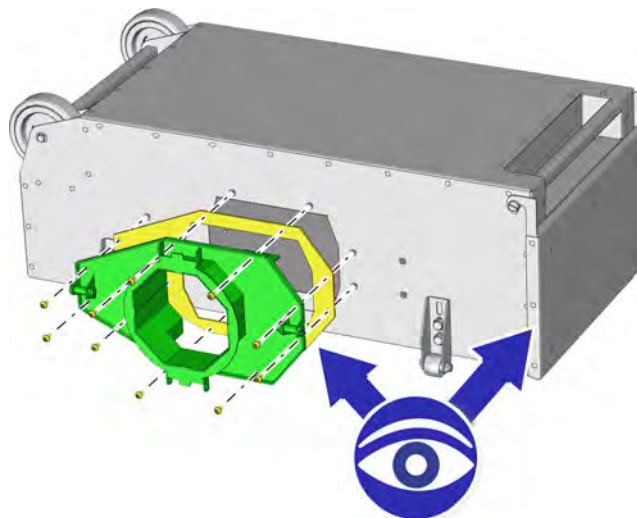

Fig. 9-45: Ash duct (stoker on left)

3. Mount the flap on the ash duct. Do not tighten the nut, so that the flap is still movable.

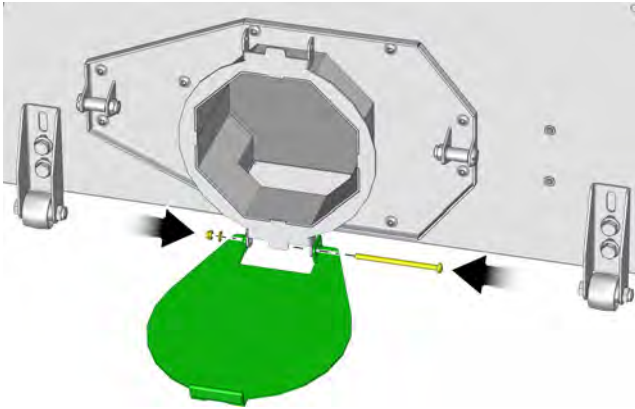

Fig. 9-46: Flap

- i** If the stoker is located on the right side of the boiler, the following graphics apply.

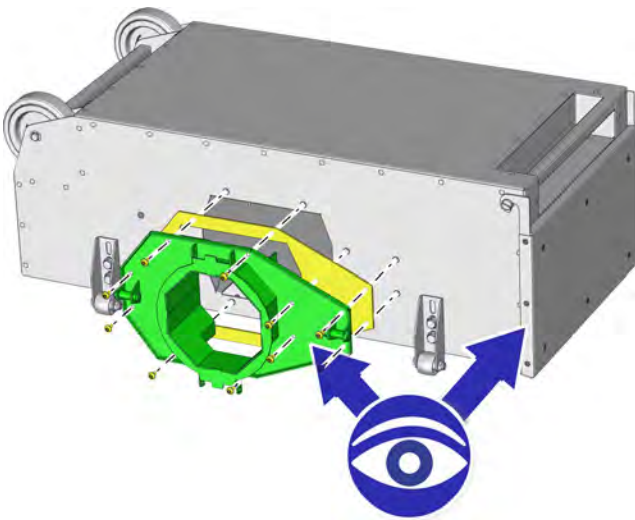

Fig. 9-47: Ash duct (stoker on right)

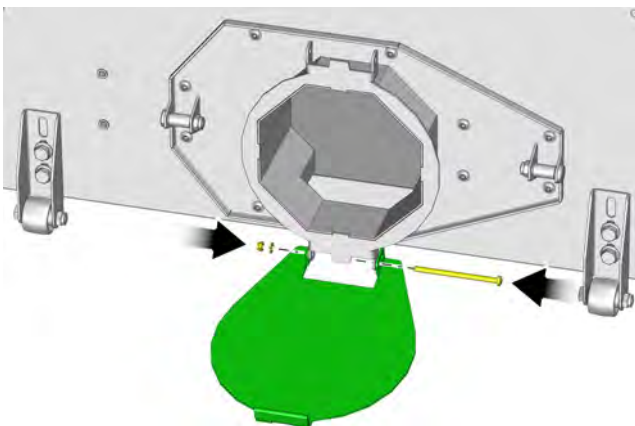

Fig. 9-48: Flap

Attaching the ash box

Open the flap on the ash box.

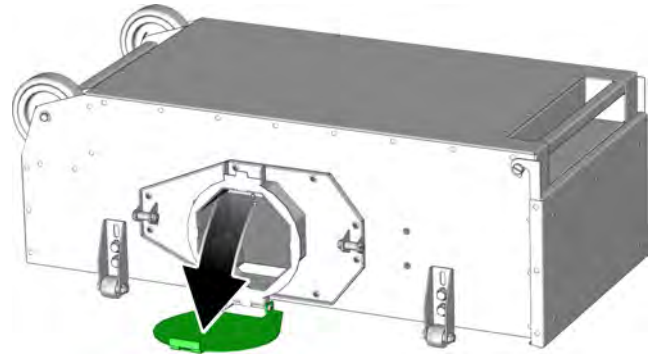

Fig. 9-49: Flap

Fold the locking lever on the boiler forwards.

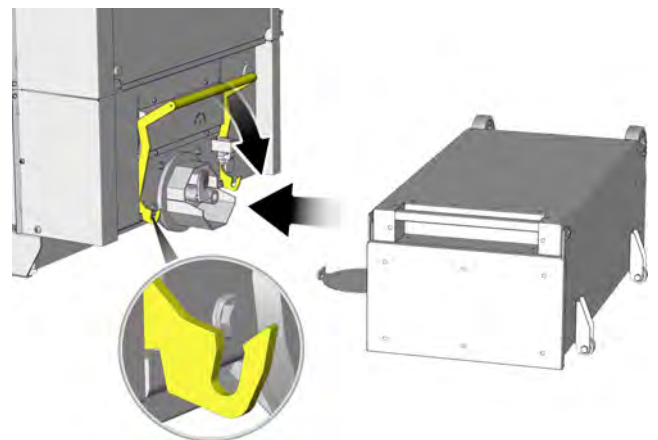
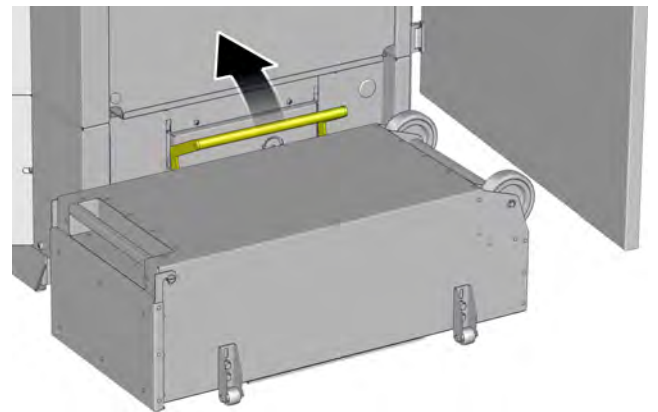

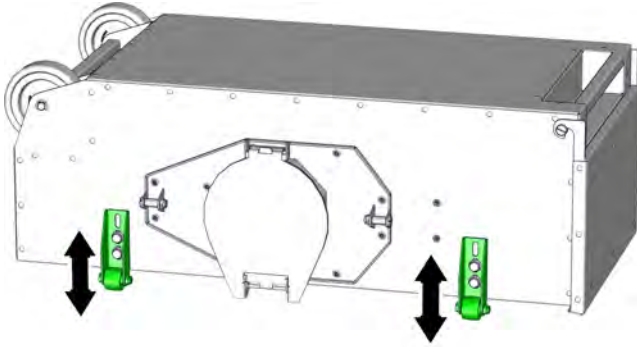

Fig. 9-50: Locking lever

Push the ash box over the connection on the boiler and connect it to the boiler with the locking lever.



-  Set the height of the attached ash box so that the ash box lies evenly on the floor.



9.11 Cables

Routing the lines to the circuit boards

Route the lines (ignition, discharge...) to the circuit boards using the cable ducts.

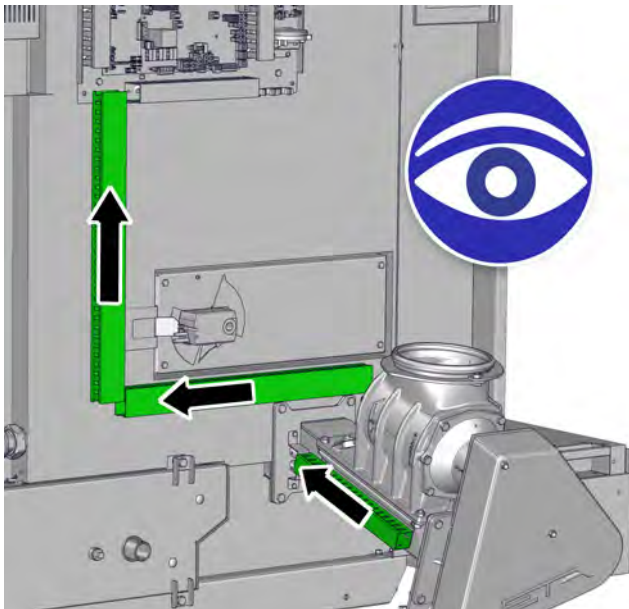



Fig. 9-51: Cable ducts

-  The cables may not run along the stoker duct since this warms up during operation.

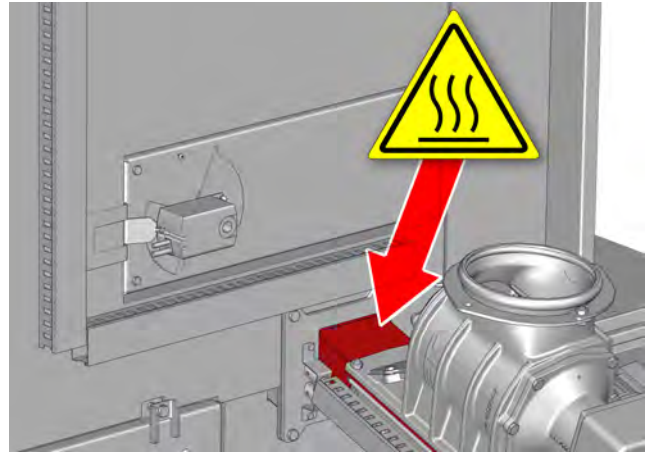



Fig. 9-52: Stoker duct

Connect boiler to potential equalisation

The boiler must be connected to the potential equalization of the boiler room or the building. Country-specific regulations must be observed.

-  The runners of the boiler features holes to connect the potential equalisation (minimum cross-section 6 mm²).

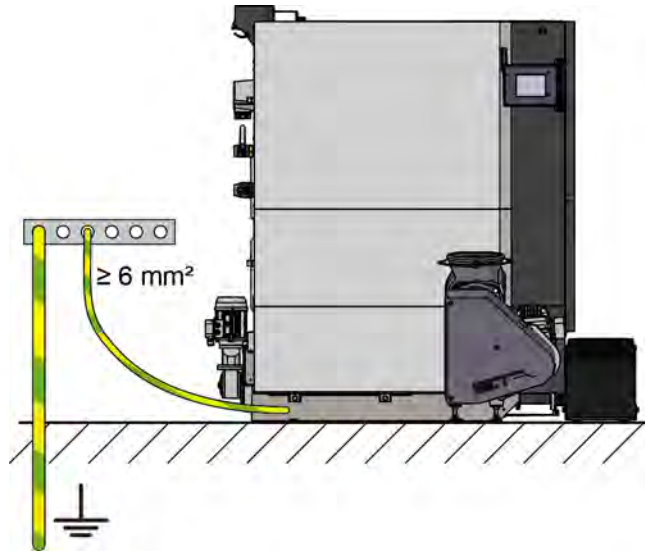

Fig. 9-53: Connect potential equalisation

9.12 Bottom insulation

Pushing in floor insulation

Connect both troughs with M5 x 6 screws. The screws are located in the ash box. Then lay the insulation in the floor pan.

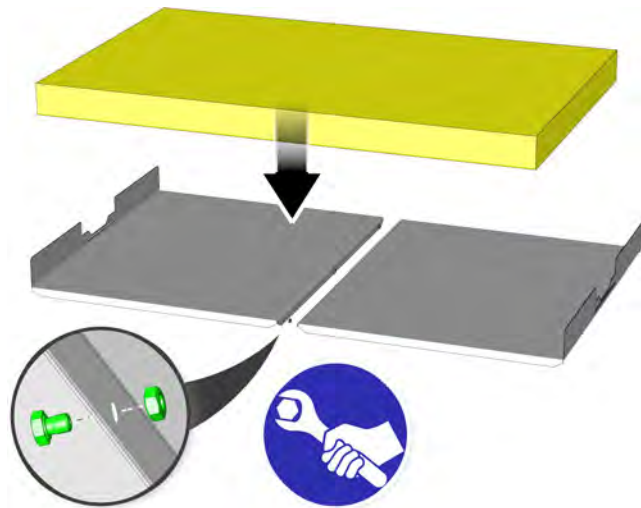

Fig. 9-54: Floor pan

Slide the metal plates into the slots in the floor pan. This pushes the insulation together in the centre section.

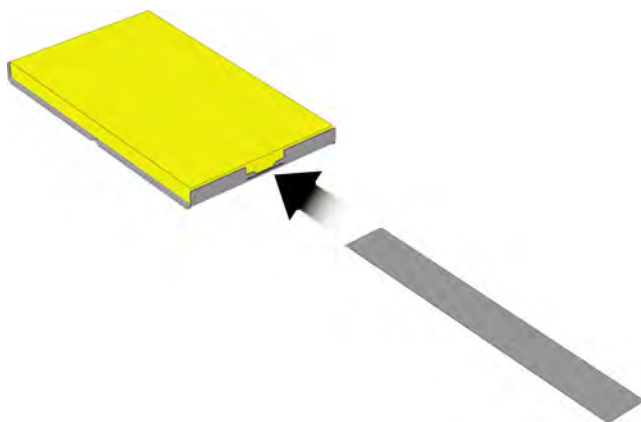

Fig. 9-55: Metal strips

Carefully push the floor pan under the boiler until it lines up with the rear end.

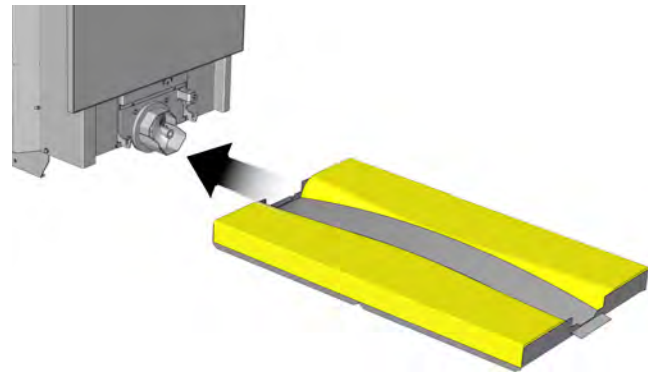

Fig. 9-56: Floor pan

Then pull the metal strips out of the floor pan and dispose of them.

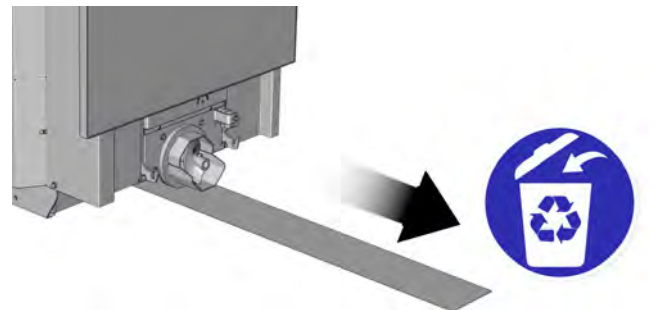
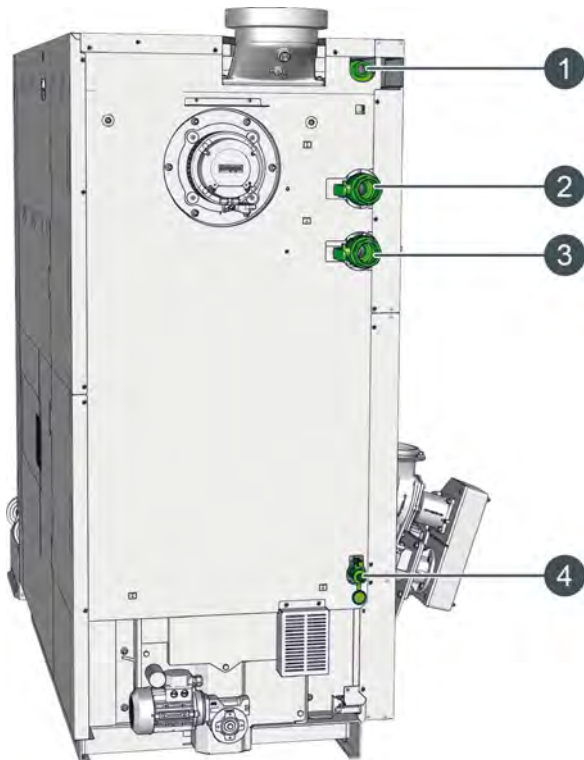

Fig. 9-57: Metal strips

9.13 Connecting piping

Connect piping to the boiler



- 1 Connection for safety valve, pressure gauge and bleed valve
- 2 Flow
- 3 Return
- 4 Filling and draining valve

Installing the thermal emergency cooling valve

Remove the plug screw from the top of the boiler and install the immersion sleeve for the capillary sensor.

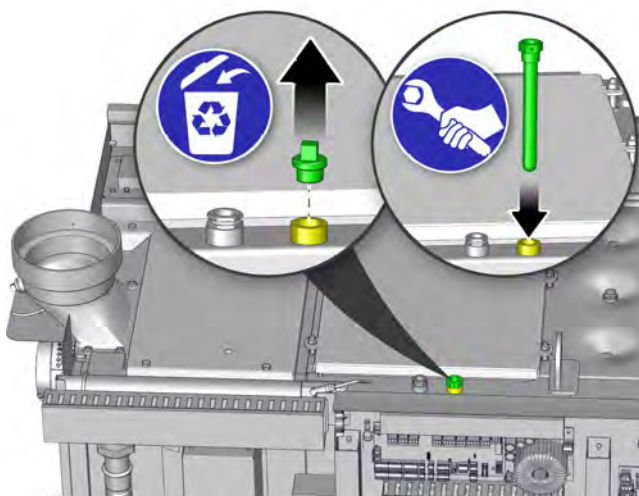

Fig. 9-58: Immersion sleeve

Install the thermal emergency cooling valve on the boiler. The connections for the safety heat exchanger are on the opposite side of the boiler.

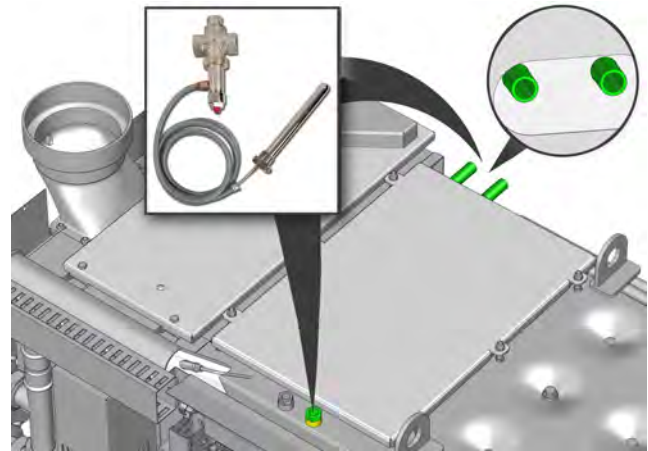
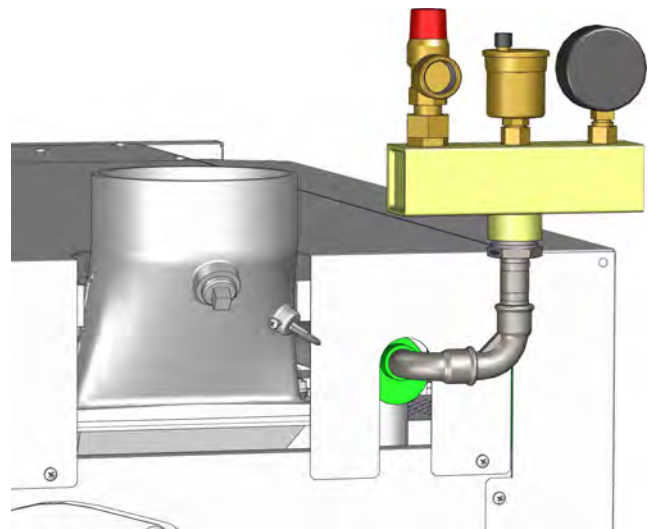

Fig. 9-59: Thermal emergency cooling valve

Installing the safety valve, pressure gauge and bleed valve

A safety valve, pressure gauge and bleed valve must be installed on the boiler. They are not included in the delivery scope.



⚠ DANGER!

Safety valve outlet

The safety valve outlet must be directed to the ground in a pipe so nobody is endangered by hot water or steam.

- ▶ The safety valve outlet must be fed to the sewage system (e.g. duct) via a clearly visible, open route (siphon funnel). This will ensure that malfunctions, especially a failure of the safety valve to close, can be detected. If no connection is available to the sewage system, the outlet must be directed to the ground in a pipe.

9.14 Filling the heating system

Filling the heating system

Fill the heating system with softened water, refer to chapter 7.3 "Water hardness".

 After filling the heating system, the handles of the ball valves must be removed from the flow and return. This ensures that the lines cannot be blocked accidentally. Fasten the handles on the rear of the boiler.

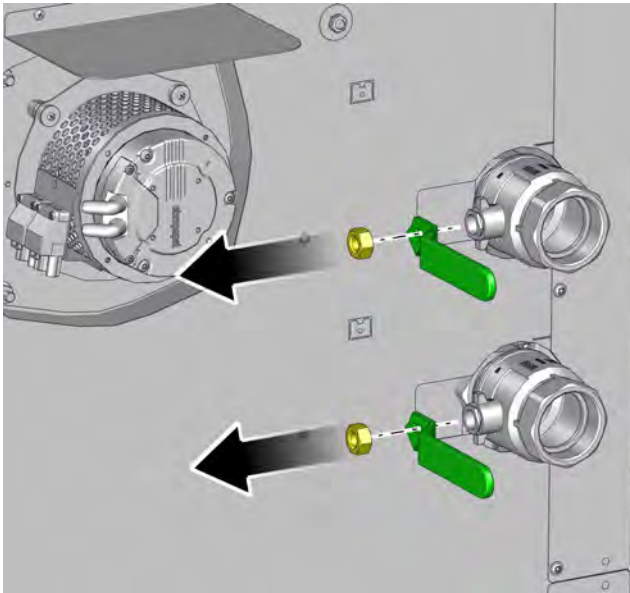

Fig. 9-60: Handles

CAUTION!

Boiler shutdown due to excessive water pressure



During operation the pressure limiter switch shuts down the boiler at a water pressure of 2.8 bar. From a water pressure of 3 bar the safety valve drains the water.

- ▶ When filling, exceed the required system pressure by no more than 0.2 bar (for bleeding).

Bleeding the heating system

Open the ball valves on the heating circuits and bleed the heating system completely. After bleeding, check the water pressure and adjust if necessary.

Checking the water-tightness of the piping

Check the water-tightness of all piping. If there is any water leakage, its cause must be found and eliminated.

9.15 Checks

Checking the position of the firebed level sensor

Remove the cover from the front of the boiler.

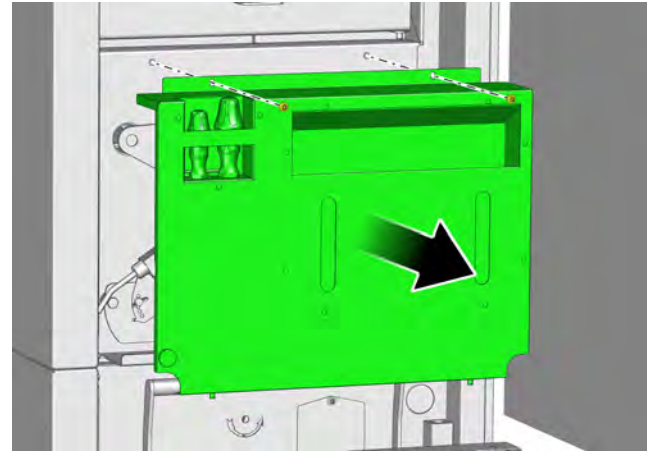

Fig. 9-61: Cover

Check the position of the firebed level sensor and whether it is correctly set for the type of fuel used. The positions for the fuels are visible on the sticker (next to the firebed level switch).

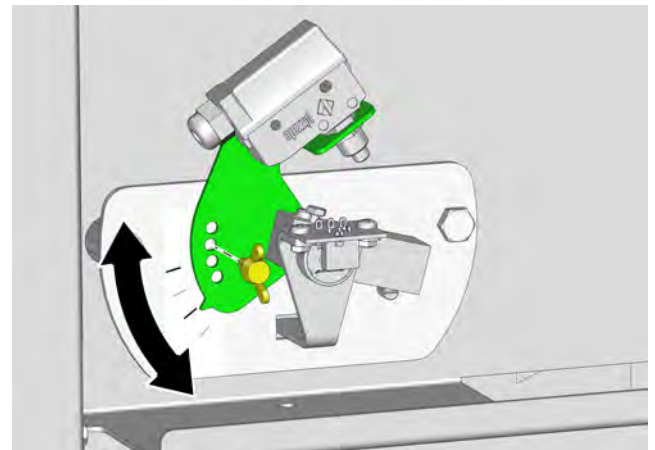

Fig. 9-62: adjustable firebed level sensor

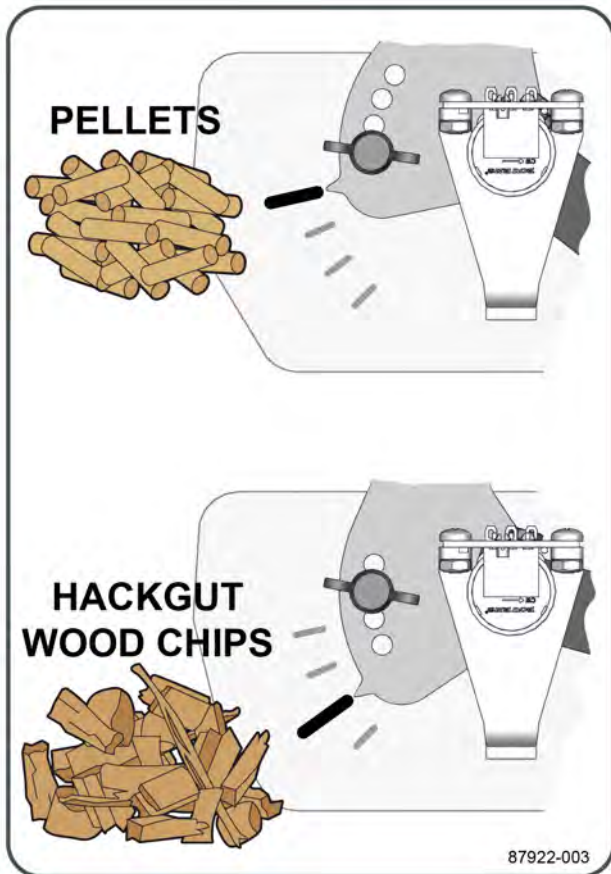

Fig. 9-63: Positions

9.16 Network connection

Connecting the network adapter for the boiler

From factory, a network cable is already connected to the control panel which extends out of the cable duct.

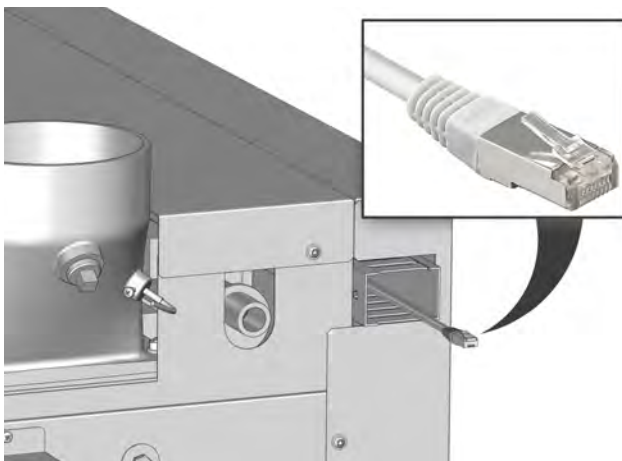



Fig. 9-64: Network cable

If the network cable is long enough, connect the plug directly into the router or the ETA PowerLine. If it is not long enough, use a network extension (1x plug / 1x socket) to connect to the router or ETA PowerLine.

10 Electrical connections

10.1 Requirements

Electrical connection must only be made by qualified specialist personnel

 The electrical installation must only be performed by specialist personnel with the corresponding qualifications.

Requirements

Observe the regulations and special regulations of local energy utilities.

 For full separation according to the setup requirements, a separating device of overvoltage category III must be installed in the permanent electrical installation. In most cases, these requirements are fulfilled with a circuit breaker, for example.

Mains protection	C 16
Mains connection	5 x 1.5 ²
Type of supply cable	H05VV-F 5G 1.5
230 VAC components:	1.0 ²
Temperature sensors:	0.5 ² - 1.0 ²

 For speed-controlled pumps (controlled via PWM signal), the maximum cable lengths of the pump manufacturer must be observed.

Maximum outputs

230 V output	Maximum power
A single output	250 W
Sum of all outputs	700 W

Potential-free output (special function)	Maximum switching capacity
A single relay output	500 W

WARNING!

Earthing of the boiler is required



Separate earthing is required for the boiler. To do so, a connection must be established between the boiler and the structural potential equalisation in the boiler room (minimum cross-section 6 mm²).

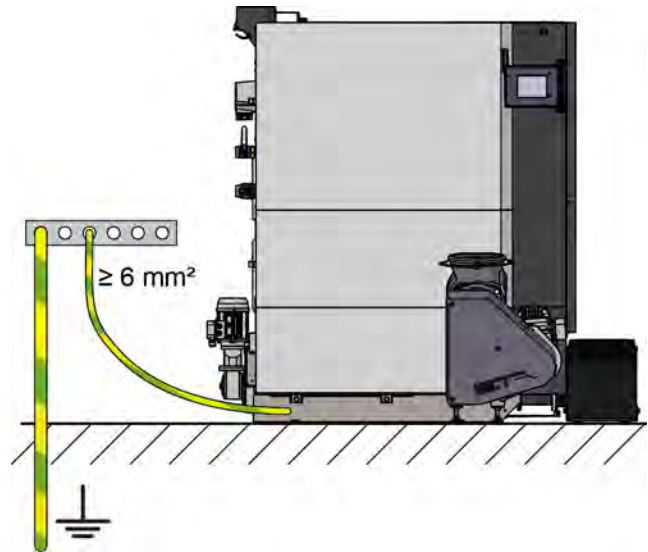

DANGER!

Do not carry out work on high voltage units



The housing of the high voltage unit may not be opened or damaged as there are parts inside it that are under high voltage.

► Non-compliance with the above may result in serious or fatal injuries.

DANGER!

Electric shock



There are live parts on the circuit boards. If touched, they can cause injury and property damage.

► Before beginning any work, isolate the system completely from all power sources, ensure that it cannot be switched back on, and verify that it is safely isolated from supply.

CAUTION!

Flexible stranded conductors

If flexible stranded conductors are not used for the wiring, the contacts in the plug connections will be subjected to excessive mechanical strain. In this case, the warranty for the electronics would become null and void.

► Only flexible stranded conductors may be used for the wiring.

Maximum line length for temperature sensor

 The maximum line length for the electrical connection of the temperature sensor is 20 m.

Strain relief required for the supply line

A strain relief is required for the supply line to the boiler. A strap is available near the cable channels for attachment.

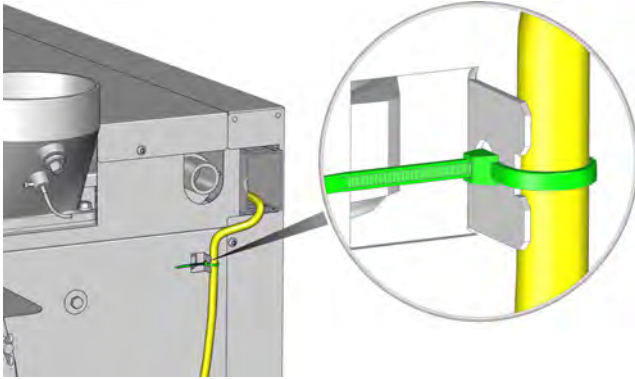

Fig. 10-1: Strain relief

Connection diagrams

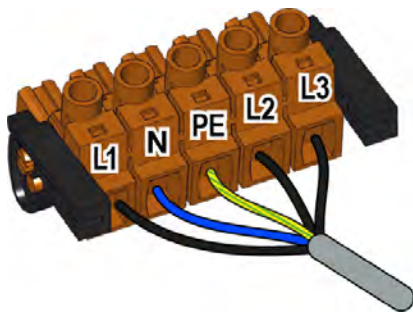

Fig. 10-2: Mains power input

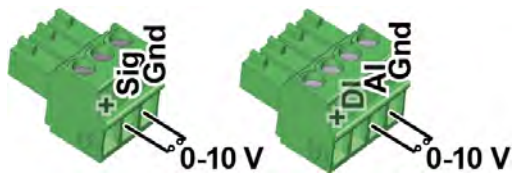

Fig. 10-3: Analogue input

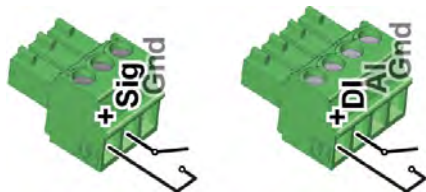

Fig. 10-4: Digital switch

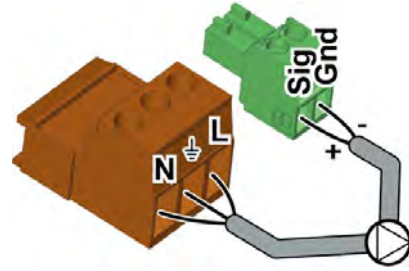

Fig. 10-5: Speed-controlled pump

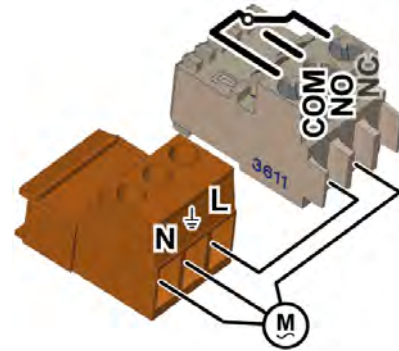

Fig. 10-6: Special function - pump (with supply extension 230 V)

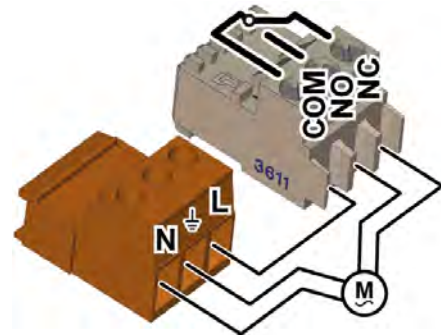

Fig. 10-7: Special function - changeover valve with three-point controlling

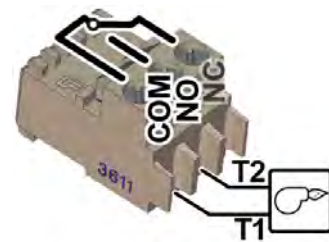
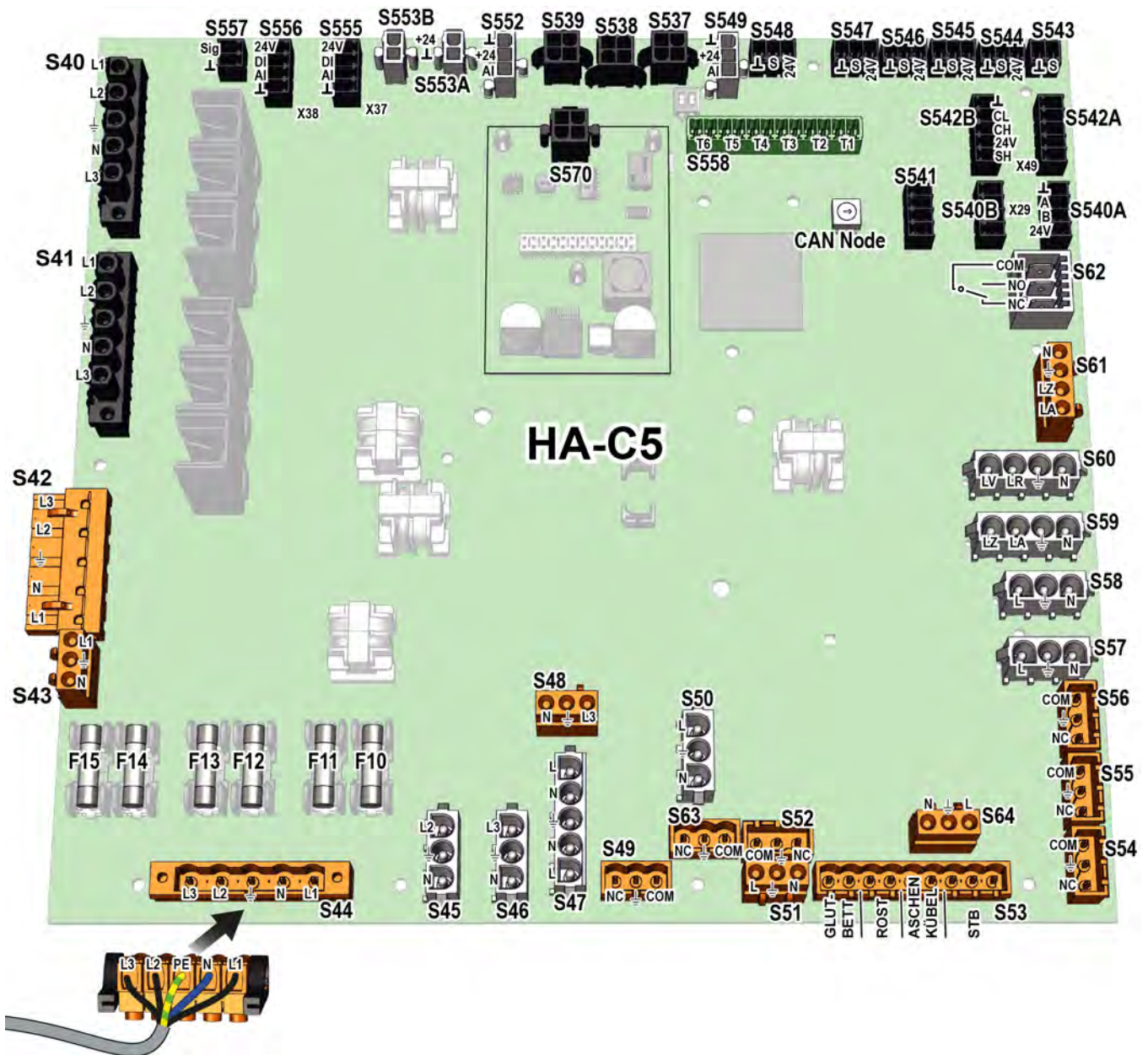

Fig. 10-8: Special function - burner

10.3 Circuit board HA-C5



i Use only flexible cables, e.g. for: pumps, mixers and temperature sensors. Shielded cables must be used for BUS lines (e.g.: CAN bus, RS485 bus).

These terminals can be used (depending on the configuration):

Terminal	Function	Minimum cross-section	Default assignment
S40	400 V output		Conveying system (intermediate conveyor screw)
S41	400 V output		Stoker screw
S44	400 V supply		Mains power input
S49	230 V input	3 x 1 mm ²	Water shortage switch
S52	230 V input	3 x 1 mm ²	Emergency stop switch

These terminals can be used (depending on the configuration):

Terminal	Function	Minimum cross-section	Default assignment
S54	230 V input		Safety switch for rotary valve maintenance cover
S55	230 V input		Safety switch at drop chute of intermediate conveyor screw
S56	230 V input		Safety switch drop chute conveying system
S62	Potential-free output (special function)		
S542A	CAN Bus	2 x 2 x 0.6 mm	
S545	24 V input		Rotary valve position sensor
S546	24 V input		Drop chute conveying system switch (intermediate conveyor screw)

These terminals have already been pre-wired at the factory:

Terminal	Function	Default assignment
CAN Node	CAN-Bus node switch	
F10	Fuse 230 V, T 5 A (electronics)	
F11	Fuse 230 V, T 8 A (Motor: [L1])	
F12	Fuse 230 V, T 5 A (ignition)	
F13	Fuse 230 V, T 8 A (Motor: [L2])	
F14	Fuse 230 V, T 5 A ([S46]: [L3], [S48]: [L3])	
F15	Fuse 230 V, T 8 A (Motor: [L3])	
S42	Locked supply extension 400 V	Cannot be used
S43	Locked supply extension 230 V	Cannot be used
S45	230 V output	Ignition
S46	230 V output	Supply for draught fan
S47	230 V input	Mains switch
S48	230 V output	Boiler pump
S50	Supply extension 230 V	to mains adapter
S51	Supply extension 230 V	to circuit board [GM-C]: terminal [S1]
S53 STB	230 V input	Safety temperature limiter (Safety temperature limiter (STB))
S53 ASCHENKÜBEL	230 V input	Ash box switch
S53 ROST	230 V input	Grate switch
S53 GLUTBETT	230 V input	Firebed switch
S57	230 V output	
S58	230 V output	Drive for heat exchanger cleaner
S59	230 V output	Tilting grate
S60	230 V output	Ash screw
S61	230 V output	Return riser mixing valve
S63	230 V input	Boiler maintenance switch

These terminals have already been pre-wired at the factory:

Terminal	Function	Default assignment
S64	230 V output	Only for precipitator: supply for the high voltage units
S537	24 V AC/DC output / Analogue input	Actuator air valve: primary air
S538	24 V AC/DC output / Analogue input	Actuator for air valve: secondary air
S539	24 V AC/DC output / Analogue input	Supply and actual position of the flue gas recirculation
S540A	RS-485 bus (for frequency converter)	Cannot be used
S540B	RS-485 bus (for frequency converter)	Cannot be used
S541	RS-485 bus	Only for precipitator: communication to the high voltage unit
S542B	CAN Bus	to circuit board [GM-C]: terminal [S508B]
S543	PWM output / analogue output	Target speed of the boiler pump
S544	24 V input	Door contact switch, insulation door
S547	24 V input	Heat exchanger cleaning monitor
S548	24 V input	Position sensor for grate
S549	Analogue input	Water pressure sensor
S552	Pulse input	Actual speed of the draught fan
S553A	24 V supply	from mains
S553B	24 V supply	to circuit board [GM-C]: terminal [S512]
S555 AI	Analogue input	Firebed level sensor
S555 DI	24 V input	
S556 AI	Analogue input	Flow rate sensor
S556 DI	24 V input	
S557	Analogue output	Target speed of the draught fan
S558 T1	Temperature input	Boiler
S558 T2	Temperature input	Return
S558 T3	Temperature input	Flue gas temperature sensor in heat exchanger
S558 T4	Temperature input	Flue gas temperature sensor on flue gas connector
S558 T5	Temperature input	
S558 T6	Temperature input	
S570	Analogue input	Lambda probe
X29	RS-485 bus terminal resistor	
X37	Jumper	for analogue input to terminal [S555] (without jumper: 0-10 V; with jumper: 0-20 mA)
X38	Jumper	for analogue input to terminal [S556] (without jumper: 0-10 V; with jumper: 0-20 mA)
X49	CAN-Bus terminal resistor	

10.4 Circuit board GM-C3

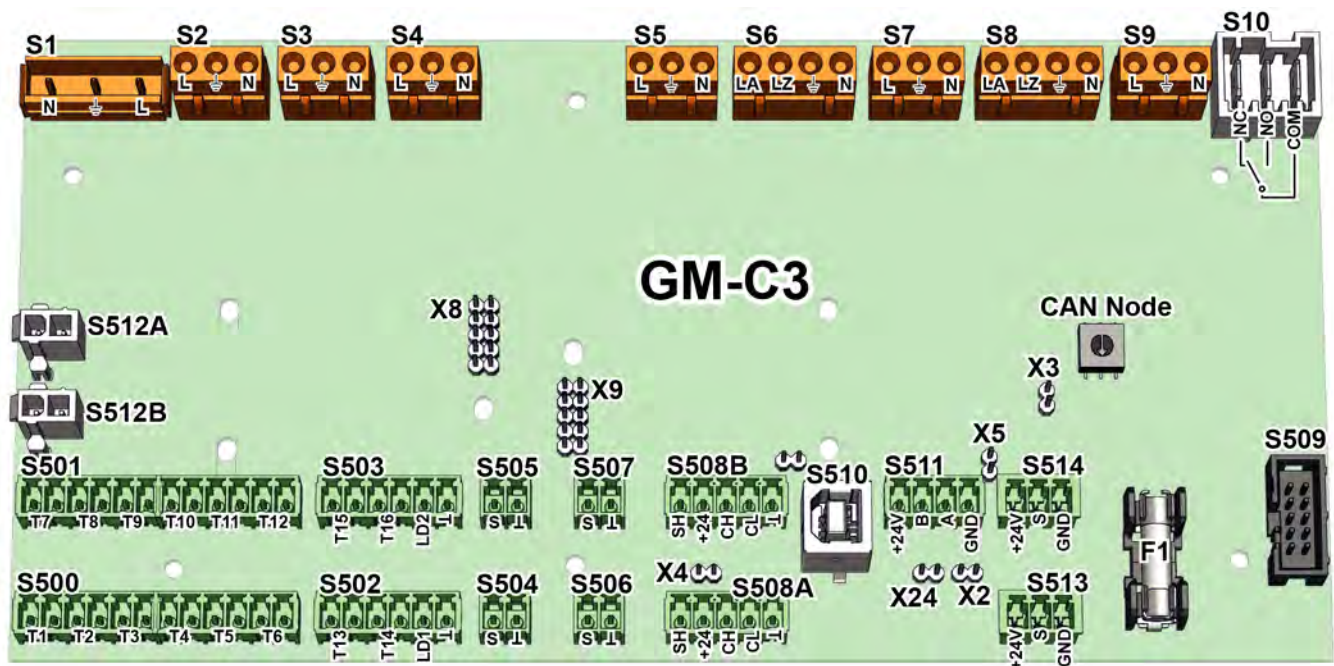

i Use only flexible cables, e.g. for: pumps, mixers and temperature sensors. Shielded cables must be used for BUS lines (e.g.: CAN bus, RS485 bus).

These terminals can be used (depending on the configuration):

Terminal	Function	Minimum cross-section	Default assignment
S2	230 V output	3 x 1 mm ²	
S3	230 V output	3 x 1 mm ²	Charging pump for hot water tank
S4	230 V output	3 x 1 mm ²	External pump / solar pump
S5	230 V output	3 x 1 mm ²	Heating circuit 2: heating circuit pump
S7	230 V output	3 x 1 mm ²	Heating circuit 1: heating circuit pump
S8	230 V output	4 x 1 mm ²	Heating circuit 1: heating circuit mixing valve
S9	230 V supply extension	3 x 1 mm ²	to circuit board [MK-E]: terminal [S15]
S10	Potential-free output (special function)		Circulation pump / burner
S500 T1	Temperature input	2 x 0.5 mm ²	
S500 T2	Temperature input	2 x 0.5 mm ²	
S500 T3	Temperature input	2 x 0.5 mm ²	
S500 T4	Temperature input	2 x 0.5 mm ²	
S500 T5	Temperature input	2 x 0.5 mm ²	Outside temperature sensor
S500 T6	Temperature input	2 x 0.5 mm ²	Collector
S501 T7	Temperature input	2 x 0.5 mm ²	Hot water

These terminals can be used (depending on the configuration):

Terminal	Function	Minimum cross-section	Default assignment
S501 T8	Temperature input	2 x 0.5 mm ²	Buffer temperature sensor 1 (top)  This temperature sensor is always mounted at the top of the buffer. If, for example, there are three temperature sensors on the buffer, then buffer temperature sensor 1 is at the top, buffer sensor 2 in the middle and buffer sensor 3 at the bottom.
S501 T9	Temperature input	2 x 0.5 mm ²	Buffer temperature sensor 2
S501 T10	Temperature input	2 x 0.5 mm ²	Buffer temperature sensor 3
S501 T11	Temperature input	2 x 0.5 mm ²	Buffer temperature sensor 4
S501 T12	Temperature input	2 x 0.5 mm ²	Buffer temperature sensor 5
S502 T13	Temperature input	2 x 0.5 mm ²	Heating circuit 1: flow
S502 T14	Temperature input	2 x 0.5 mm ²	
S502 LD1	LED output	2 x 0.5 mm ²	
S503 T15	Temperature input	2 x 0.5 mm ²	Heating circuit 2: flow
S503 T16	Temperature input	2 x 0.5 mm ²	
S503 LD2	LED output	2 x 0.5 mm ²	
S504	PWM output / analogue output	2 x 0.5 mm ²	Speed for pump on terminal [S2]
S505	PWM output / analogue output	2 x 0.5 mm ²	Speed for pump on terminal [S3]
S506	PWM output / analogue output	2 x 0.5 mm ²	Speed for pump on terminal [S4]
S507	PWM output / analogue output	2 x 0.5 mm ²	Speed for pump on terminal [S5]
S508A	CAN Bus	2 x 0.6 mm	
S511	RS-485 bus	2 x 0.6 mm	Digital room sensor

These terminals have already been pre-wired at the factory:

Terminal	Function	Default assignment
CAN Node	CAN-Bus node switch	
F1	Fuse T 500 mA (24 V supply)	
S1	230 V supply	from circuit board [HA-C]: terminal [S51]
S6	230 V output	Grate 2
S508B	CAN Bus	from circuit board [HA-C]: terminal [S542B]
S509	Signal line	to circuit board [MK-E]: terminal [S517]
S510	Data line	to ETAtouch control panel
S512A	24 V supply	from circuit board [HA-C]: terminal [S553B]
S512B	24 V supply	
S513	Analogue input	Position sensor for grate 2
S514	Analogue input	Vacuum sensor
X2	CAN Bus supply GND (for standalone mode)	
X3	Boot jumper	
X4	CAN-Bus terminal resistor	

These terminals have already been pre-wired at the factory:

Terminal	Function	Default assignment
X5	RS-485 terminal resistor	
X8	Terminal for plug-in circuit board	
X9	Terminal for plug-in circuit board	
X24	CAN-Bus supply +24 V (for stand-alone operation)	

11 Concluding activities

Reinstall boiler casing

Reinstall the parts of the boiler casing that were removed during the assembly.

Removing protective film

Remove protective film from all covers. After longer periods of operation of the boiler, the film can no longer be removed without damaging the paint.

Checking the drive's direction of rotation

Mark the drive by drawing a line over the screw, washer and drive.

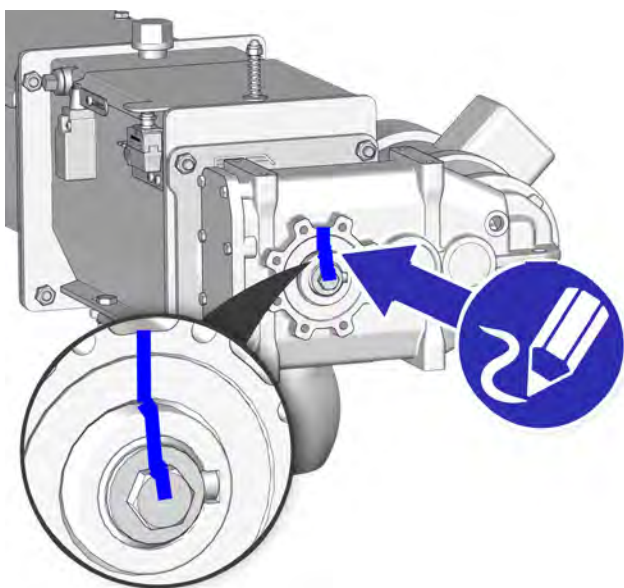



Fig. 11-1: Marking

In the function block of the boiler, switch to the inputs and outputs menu. Select the stoker unit [Stoker unit] and press the  button for manual operation. Only start the discharge drive with the [Fwd] button.

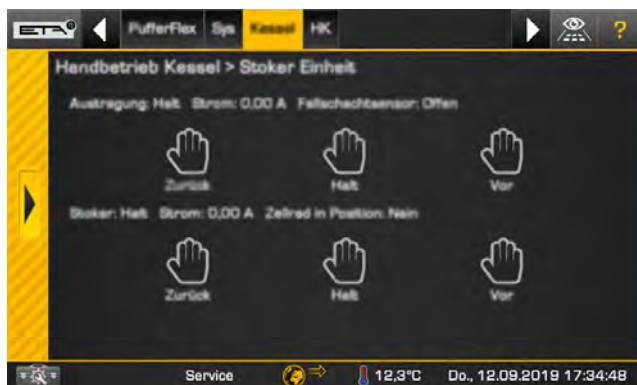

Fig. 11-2: Menu for manual operation

Check the direction of rotation of the drive with the aid of the marking. The correct rotation direction is shown in the following diagram.

If the rotation direction is not correct, check the drive's electrical connection.

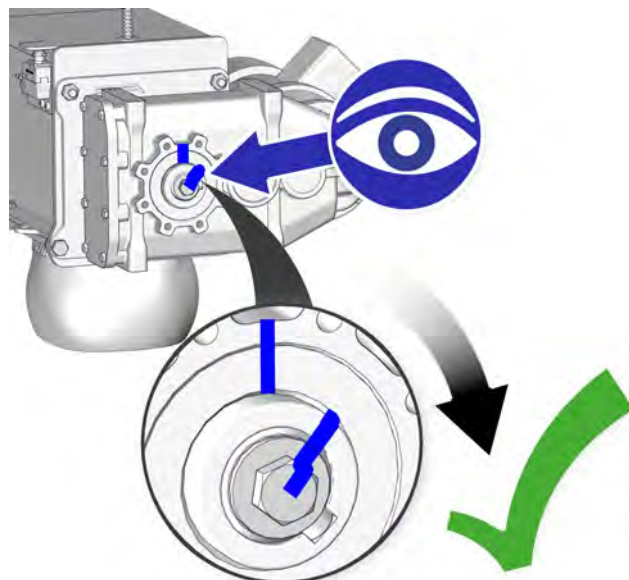

Fig. 11-3: Correct direction of rotation

12 Fuel store

12.1 Requirements

General requirements for wood chip storage

- Do not step onto the fuel mound. An increased risk of injury due to bridging and the associated risk of collapse of the fuel mound exists.
- Firefighting equipment must be kept visible and unobstructed.
- The wood chip storage must be protected against weathering (especially rain and moisture). It must be lockable, if possible, in order to prevent unauthorized access (for example: by children playing).
- Irrespective of the discharge systems, the maximum extensions, inclinations and filling heights must be observed, see chapter [12.6 "Technical data"](#).
- The country-specific building and fire protection regulations must be observed.

Wood chip storage ventilation

For wood chip storages in Austria, a minimum ventilation cross-section of 400 cm² to the outside must be provided (see ÖNORM H 5170).

 A protective screen at the air intake opening, however, reduces the free cross section. Therefore, the air inlet opening must be larger, depending on the protection grill. For air ducts through channels, an expert calculation is required.

This value may differ depending on the country-specific standards. Enquire about this with your authorities. If no rules exist, we recommend using the Austrian minimum cross sections as a guide.

Maintenance opening

In the wall opening between the fuel store and the boiler room, a maintenance opening should be installed above the conveying system's closed trough. It requires an opening of 215x155 mm in the wall.



Fig. 12-1: Maintenance opening

- 1 Storeroom cover
- 2 Opening in the masonry
- 3 Maintenance door (fire protection door EI30 required)

12.2 Dimensioning

The right solution for any storeroom

In order for a wood chip heater to be planned correctly, the first question is: How will I fill the storeroom? For this reason, we recommend looking at the possibility of pre-filling the storeroom. Because filling can depend on whether existing structures and machines are to be used, or whether reconstruction and acquisitions are planned. A newly erected ground-level storeroom can be filled with a front loader or telescopic loader, and an existing silo with a filling system. Therefore, make an effort to find the most convenient solution for filling the storeroom.

Once the filling method has been clarified, determine the storeroom dimensions. In principle, this should be dimensioned as large as possible, so that less frequent filling is required.

Dimensioning of the storeroom

To dimension the storeroom, the expected fuel consumption must first be determined. This can either be estimated from the boiler output, or from the running hours of the boiler.

Estimation based on boiler output

The formula for this is as follows:

$$V_{srm} = P_k \cdot 2,5$$

V_{srm}	... Volume in loose cubic metres in [m ³].
	A loose cubic metre (srm) corresponds to 1 m ³ of loosely filled wood chips.
P_k	... Boiler output in [kW]

Example:

For a boiler with an output of 50 kW and average fuel quality, an annual consumption of approximately 125 cubic metres is expected.

$$V_{srm} = 50 \cdot 2,5 = 125 \text{ srm}$$

 For higher fuel qualities (low contamination, low bark, low water content), this is reduced by a factor of "2". For the above example, the annual consumption is reduced to approx. 100 cubic metres.

Estimation based on running hours

The formula for this is as follows:

$$V_{srm} = \frac{P_k \cdot t_{VLH}}{Hw}$$

V_{srm}	... Volume in loose cubic metres in [m ³]
P_k	... Boiler output in [kW]
t_{VLH}	... Maximum permissible full load hours of the boiler per year in [h]. This is stated in the guarantee conditions of the respective boiler.
Hw	... Calorific value of the fuel in [kWh/srm]

Example:

For a boiler with an output of 50 kW and spruce wood chips of size "P16S" with 30% water content, the resulting annual consumption is about 128 cubic metres.

$$V_{srm} = \frac{50 \cdot 2000}{780} = 128 \text{ srm}$$

 You can find the heating values of different fuels in chapter [12.5 "Heating value"](#).

Determining the number of refills

With an agitator with a diameter of 4 m and a maximum filling height of 5 m, a storage volume of

about 62.8 m³ (= ((d² x π)/4) x filling height) is achieved.

With an annual consumption of 128 m³, the storeroom must be filled twice per year (128 / 62.8 = 2).

 However, if a 6 m diameter agitator is used instead of the 4 m agitator, a storage volume of approx. 141 m³ is obtained at a maximum fill height of 5 m. With a consumption of 128 m³, the storeroom must therefore only be filled once per year.

Floor agitator dimensioning

The rotation of the floor agitator clears a circular area in the storeroom. In a storeroom with corners, a portion of the fuel will always remain unused in the corners. To use all of the fuel, a round storeroom (maximum diameter 6 m) would be preferable.

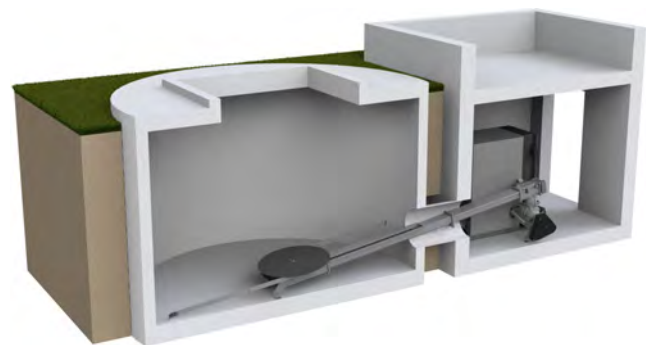

For a storeroom with, for example, interior dimensions of 4 x 4 m a floor agitator with a diameter of 4 m would usually be used. However, a slightly larger floor agitator with 4.5 m diameter can also be used. With it, the flat spring arms are able to reach the otherwise inaccessible corners of the fuel store and can also clear out the fuel there. This requires planning, because the open trough must be located entirely in the storeroom and should not protrude through the wall.

When there is little fuel in the storeroom, the flat spring arms are relaxed and extend to the inner walls. To avoid damaging the walls, boards should be attached to them at the height of the flat spring arms.

 To prevent bridging in the fuel store, the size of the floor agitator should never be smaller than the diameter of the storeroom.

 If the storeroom is square, a larger floor agitator can be installed. It is acceptable for the flat spring arms to strike the edge of the storeroom and also convey the fuel there. In order to protect the masonry, wooden panels can be fitted all around, against which the flat spring arms can strike. This also minimizes the risk of bridging. However, it must be noted that the open trough must not be located in the wall. Therefore, the floor agitator is to be offset from the centre. Plans for this are available from ETA.

Maximum fill height

The maximum fill height for wood chips is 5 m (approx. 200 kg/ m³). Due to the greater weight (approx 650 kg/m³) with a floor agitator, pellets can only be filled up to a maximum height of 2 m.

If the fill height is more than twice the diameter of the agitator (e.g. higher than 4 m for an agitator with 2 m diameter), there is a risk of cavitation (also called bridging). This is especially the case with wood chips with a high water content, a lot of fine content or shredded wood chips.

Cavity formation means that the wood chips wedge into each other and no longer slip into the agitator. This creates a cavity above the agitator over time, which is not visible from the outside. This is often only noticed when the boiler outputs an error message because no more wood chips reach the boiler. The remedy here is to poke in the wood chips with, e.g. rods, so that the hollow space collapses.

 For this reason it is forbidden to enter the wood chip store, especially the area above the agitator, because there is a danger of collapse due to the formation of cavities and thus an increased risk of injury.

12.3 Tilted floor

Slanted floor for the fuel

With a slanted floor in the storeroom, the fuel cannot get under the floor agitator so no unused space results. Without the slanted floor, the space under the flat spring arms is filled first when filling the fuel store. This volume is not accessible to the flat spring arms and remains unused and over time the material there will decay.

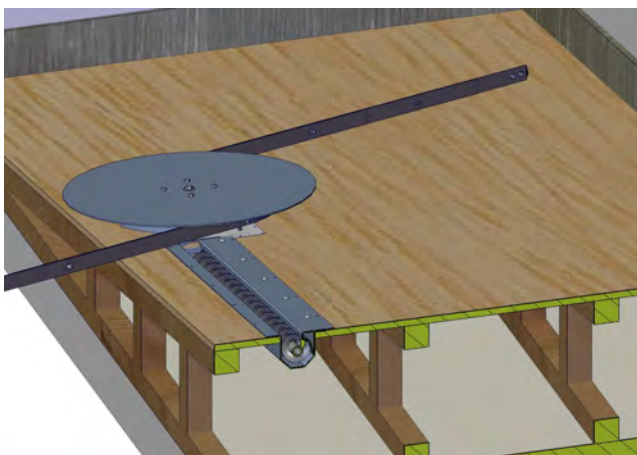

Fig. 12-2: Slanted floor

Benefits of the slanted floor:

- The flat spring arms move along the floor and cannot "float" over the fuel.

- The fuel is not compacted in the outer area of the floor.

However, some points have to be considered when building a slanted floor:

- The static load upon the substructure must be considered.
- A slanted floor is required for operation with pellets.
- For the cavity below the slanted floor, sufficient ventilation must be provided so that moisture can escape. Country-specific regulations are to be observed.
- The cavity under the slanted floor forms a resonating body. As a result, sound transmissions can be generated throughout the residential building or adjacent structures.

 If the fuel storage is located in a residential building or adjacent to one, a slanted floor is not recommended.

 If no slanted floor is installed, the first filling of the storeroom must be performed with dry wood chips. Because these remain on the floor and later form the support for other fillings. In contrast, moist wood chips would slowly rot, thus reducing the heating value of later fills.

12.4 Pellet operation

Wood chip boiler with pellet operation

If there is little space for a wood chip store, pellets are the ideal solution, as the energy density of pellets is about four times as high as that of wood chips. So for the same heat output you only need a quarter of the storeroom.

A boiler with an output of 45 kW requires approximately 15 tons of pellets per year, which corresponds to a storage space size of 23 m³. For annual filling, a storeroom volume of just 30 m³ including a pellet reserve is sufficient.

 For the fuel discharge, either an agitator or a pellet discharge screw can be used.

 Special requirements apply to pellet storage rooms. For more information, please contact ETA.

Floor agitator for pellets

For pellet operation with a floor agitator, the following points must be observed:

- Pellets are much heavier than wood chips. Which is why floor agitators may only be filled with pellets up to a height of 2 metres.

- To ensure that the pellets are not damaged, only floor agitators up to a maximum of 4 metres in diameter may be used, and the angle of inclination may not exceed 12°.
- A special cover plate for pellets is needed on the open trough screw in the store to prevent overfilling of the discharge screw.
- The trough screw between store outlet and boiler may be a maximum of 1.5 metres long.



Fig. 12-3: Floor agitator for pellets

Pellet discharge screw

If the boiler is operated exclusively with pellets, then a pellet discharge screw is the better solution. This is due to the fact that more pellets can be filled with this solution. Please note that the screw must be routed to the boiler for this conveying system. The maximum fill height for a pellet discharge screw is 7 m.

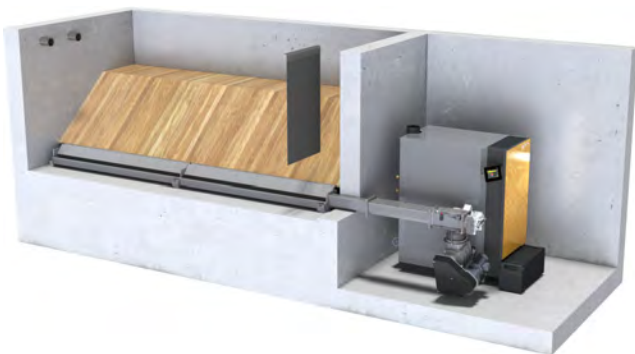
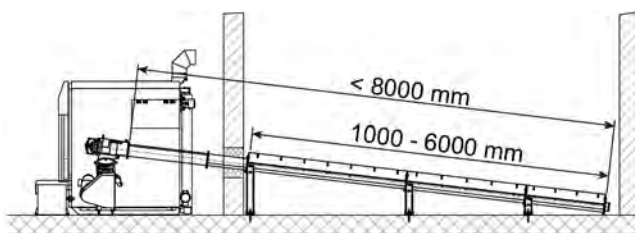

Fig. 12-4: Discharge screw for pellets



12.5 Heating value

Heating values of fuels

	Heating value based on weight		Cubic metre (rm) ^a				Loose cubic metre (srm) ^b							
			Logs				Wood chips P16S				Wood chips P31S			
			Weight		Heating value		Weight		Heating value		Weight		Heating value	
Water content	15%	30%	15%	30%	15%	30%	15%	30%	15%	30%	15%	30%	15%	30%
Unit	kWh/kg	kWh/kg	kg/rm	kg/rm	kWh/rm	kWh/rm	kg/srm	kg/srm	kWh/srm	kWh/srm	kg/srm	kg/srm	kWh/srm	kWh/srm
Softwood			1 rm = 0.65 fm ^c		1 rm = 0.56 fm ^c		1 srm = 0.40 fm ^c				1 rm = 0.33 fm ^c			
Fir	4.40	3.51	276	317	1210	1110	178	205	780	720	148	171	650	600
Spruce	4.49	3.58	293	337	1310	1210	189	218	850	780	157	181	710	650
Douglas fir	4.43	3.53	319	368	1410	1300	206	237	910	840	172	198	760	700
Pine	4.32	3.44	360	414	1550	1420	232	267	1000	920	193	223	830	770
Larch	4.27	3.39	370	426	1580	1450	239	275	1020	930	199	229	850	780
Hardwood			1 rm = 0.59 fm ^c		1 rm = 0.50 fm ^c		1 srm = 0.40 fm ^c				1 rm = 0.33 fm ^c			
Poplar	3.99	3.16	256	295	1020	930	174	200	690	630	145	167	580	530
Willow	3.76	2.97	320	369	1200	1100	217	250	810	740	181	208	680	620
Alder	4.06	3.23	313	361	1270	1160	212	245	860	790	177	204	720	660
Maple	4.04	3.21	384	443	1550	1420	260	300	1050	960	217	250	880	800
Birch	4.01	3.18	391	450	1570	1430	265	305	1060	970	221	254	890	810
Ash	4.10	3.25	429	494	1760	1610	291	335	1190	1090	242	279	990	910
Oak	4.10	3.25	429	494	1760	1610	291	335	1190	1090	242	279	990	910
Beech	4.13	3.28	435	502	1800	1640	302	347	1220	1110	251	289	1010	930
Robinia	4.11	3.27	467	538	1920	1760	317	365	1300	1190	264	304	1090	990

a. A cubic metre (rm) corresponds to 1 m³ layered logs (1 m length) with air gaps.

b. A loose cubic metre (srm) corresponds to 1 m³ of loosely dumped wood chips.

c. A solid cubic metre (fm) corresponds to 1 m³ wood without air gaps.

12.6 Technical data

Maximum lengths and inclines

Below you will find the information on the maximum lengths and inclinations for conveying systems of different sizes.

 If deviations from the stated values are necessary, please consult ETA Heiztechnik GmbH.

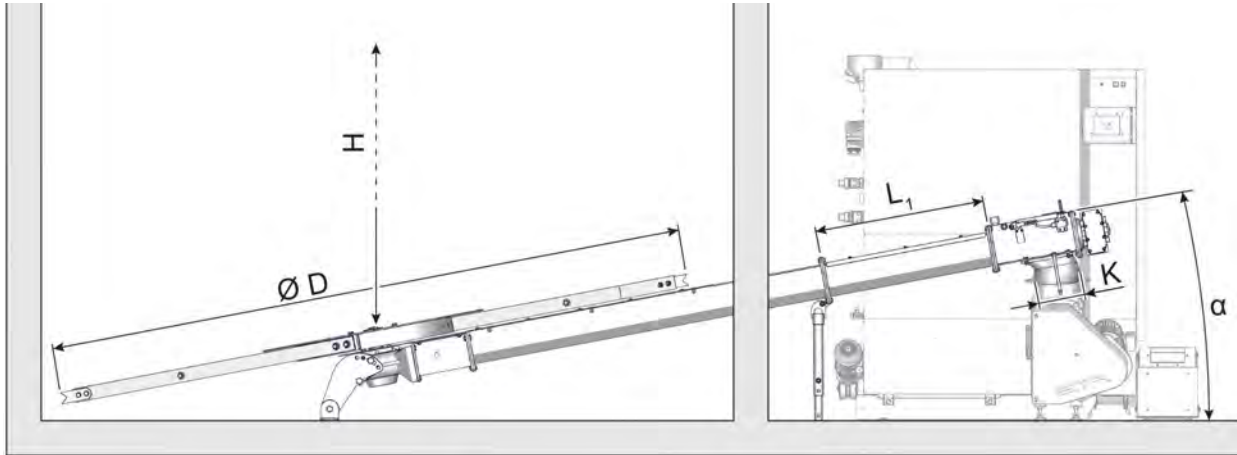

Fig. 12-5: Side view

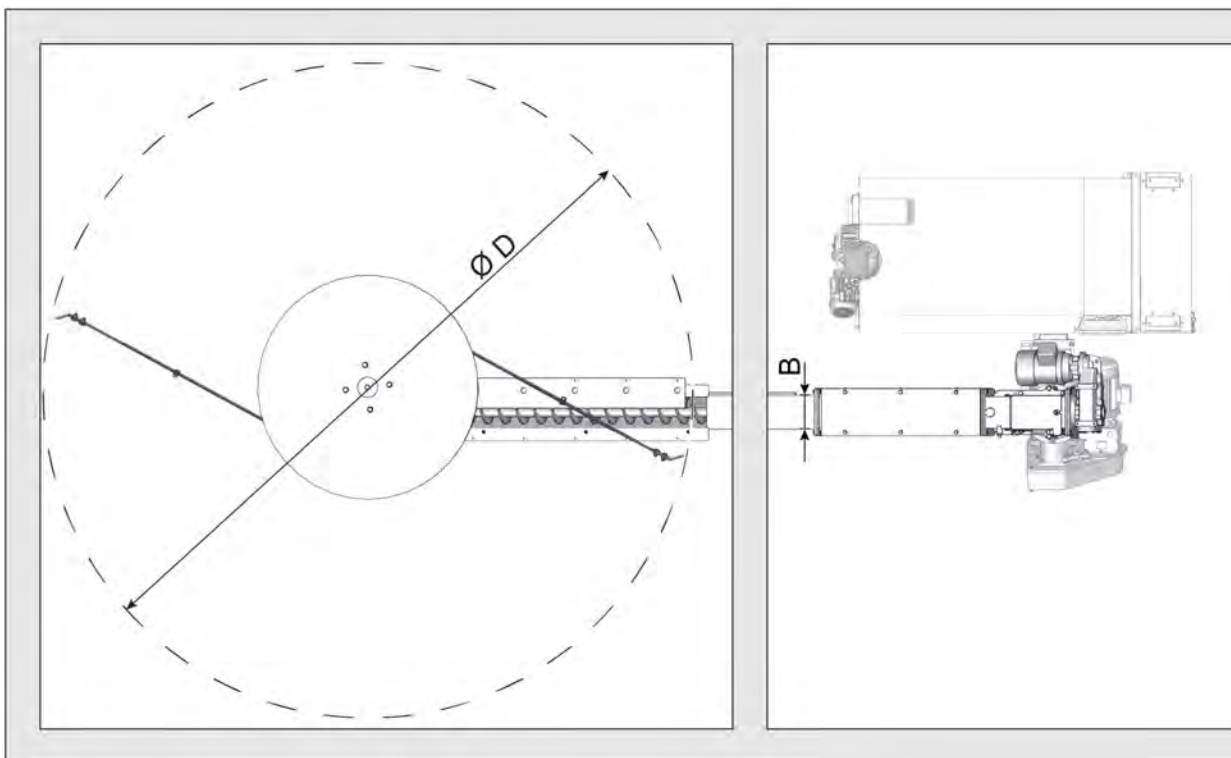



Fig. 12-6: Top view

Discharge	Unit	BG 1	BG 2	BG 2.5	BG 3
Trough - width B	mm	140	190		230
Ball joint - diameter K	mm	200		250	
compatible boilers:					
eHACK	kW	20 - 80	100 - 170	180 - 240	
HACK VR	kW	-	-	250	333 - 350 500

Agitator for wood chips

Discharge	Unit	BG 1	BG 2	BG 2.5	BG 3
Floor agitator - Diameter D and drive power:					
with leaf spring arm	m	1.5 - 4	3 - 4		
	kW	0.37	0.55	1.1	1.5
with articulated arm	m	4.5 - 5			
	kW	0.55	1.1		1.5
with double articulated arm	m	5.5 - 6			
	kW	0.55	1.1		1.5
closed trough:					
Total length L ₁	m	< 6			
Inclination α		< 15°			
Fill height H	m	< 5			
Number of spring arms		2			

 Deviations from these specifications are only possible in consultation with ETA Heiztechnik GmbH.

Agitator for pellets

Discharge	Unit	BG 1	BG 2	BG 2.5	BG 3
Floor agitator - Diameter D and drive power:					
with leaf spring arm	m	2	2.5 - 4	3 - 4	
	kW	0.37	0.55	1.1	1.5
closed trough:					
Total length L ₁	m	< 2.5			
Inclination α		< 12°			
Fill height H	m	< 2			
Number of spring arms		2	4		

 For pellet operation, a conversion kit is required for the floor agitator and trough.

13 Dismantling, disposal

Dismantling

Before dismantling:

- Stop heating. Switch off the boiler with the mains switch and ensure that it cannot be switched back on.
- Disconnect the boiler (and possibly also the fuel conveying system) from all power sources.

Dismantling is done in the reverse order of assembly.

Clean the parts and remove them in accordance with the local regulations for workplace safety and environmental protection.

Disposal

Disposal including all components must be done in an environmentally friendly manner according to waste disposal laws. Recycle any materials that can be recycled.





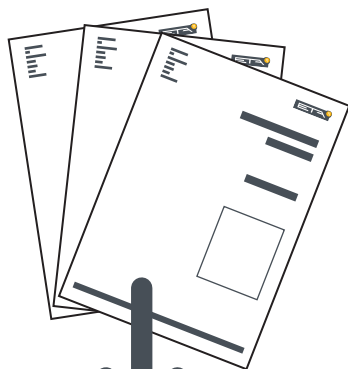

DOWNLOAD



www.eta.co.at/downloads