018316
INSTALLATION & OPERATION
GUIDELINES FOR SINGLE PIECE UNITS
BIODISC® BN



Kingspan Water & Energy Service Contact Numbers:

UK: 0333 240 6868

NI: 028 3836 4600

ROI: 0818 543 500

Enclosed Documents

DS1334	BN BioDisc General Assembly – Sales Drawing
--------	---



Issue	Description	Date
03	ECR/ECN 2216	June 2025
02	ECN 1621 / ECN 1650	January 2023
01	Initial Issue – CC1392	August 2017

HEALTH AND SAFETY

These warnings are provided in the interest of safety. You must read them carefully before installing or using the equipment.

It is important that this document is retained with the equipment for future reference. Should the equipment be transferred to a new owner, always ensure that all relevant documents are supplied in order that the new owner can be acquainted with the functioning of the equipment and the relevant warnings.

Installation should only be carried out by a suitably experienced contractor, following the Guidelines supplied with the equipment.

We recommend the use of a dust mask and gloves when cutting GRP components.

Electrical work should be carried out by a qualified electrician.

Sewage and sewage effluent can carry micro-organisms harmful to human health. Any person carrying out maintenance on the equipment should wear suitable protective clothing, including gloves. Good hygiene practice should also be observed.

Covers must be kept locked.

Observe all hazard labels and take appropriate action to avoid exposure to the risks indicated.

The correct ongoing maintenance is essential for the proper operation of the equipment. Kingspan offer a range of maintenance contracts, details on request.

Should you wish to inspect the operation of the equipment, please observe all necessary precautions, including those listed below, which apply to maintenance procedures.

BioDisc units contain rotating machinery and associated transmission equipment.

Ensure that you are familiar with the safe working areas and accesses.

Ensure that the working area is adequately lit.

The power supply to the equipment must be isolated at the control panel(s) before lifting the covers. Where a specific maintenance procedure requires the equipment to be running with the covers off, all care must be taken to avoid contact with moving parts and electrical components or conductors. Drive guards must be replaced and secured if removed during maintenance.

Once power has been isolated, the control panel must be kept locked shut to avoid accidental re-connection whilst work or inspection is being carried out.

Use only the designated access walkways. Do not walk on the cover.

Take care to maintain correct posture, particularly when lifting. Use appropriate lifting equipment when necessary. Keep proper footing and balance at all times. Avoid any sharp edges.

Desludging should be carried out by a contractor holding the relevant permits to transport and dispose of sewage sludge. The contractor must refer to the desludge instructions in the operation section of this manual.

CONTENTS

	Page
HEALTH AND SAFETY	2
1 Introduction	4
2 Technical Data	5
3 Handling & Storage	6
4 Site Planning	7
5 Installation	8
5.1 General	8
5.2 BioDisc Installation	9
5.3 Control Panel – Installation.....	10
5.4 Control Panel - Connection	11
5.5 Ancillary Equipment	13
6 Start Up	21
6.2 Automatic grease cartridges	21
6.3 Optional Pump Station	21
6.4 BioDisc	22
6.5 Switch-on	22
6.6 Process Initiation.....	22
7 Operation	22
7.2 Do’s and Don’ts	23
7.3 Automatic Restart.....	23
8 Running Checks	24
8.2 Loss of Rotation Alarm	24
8.3 Customer Checks.....	24
9 Desludging and Maintenance	24
9.2 Sludge Removal	25
9.3 Desludge Volumes	26
10 Warranty.....	27
11 Notice	28

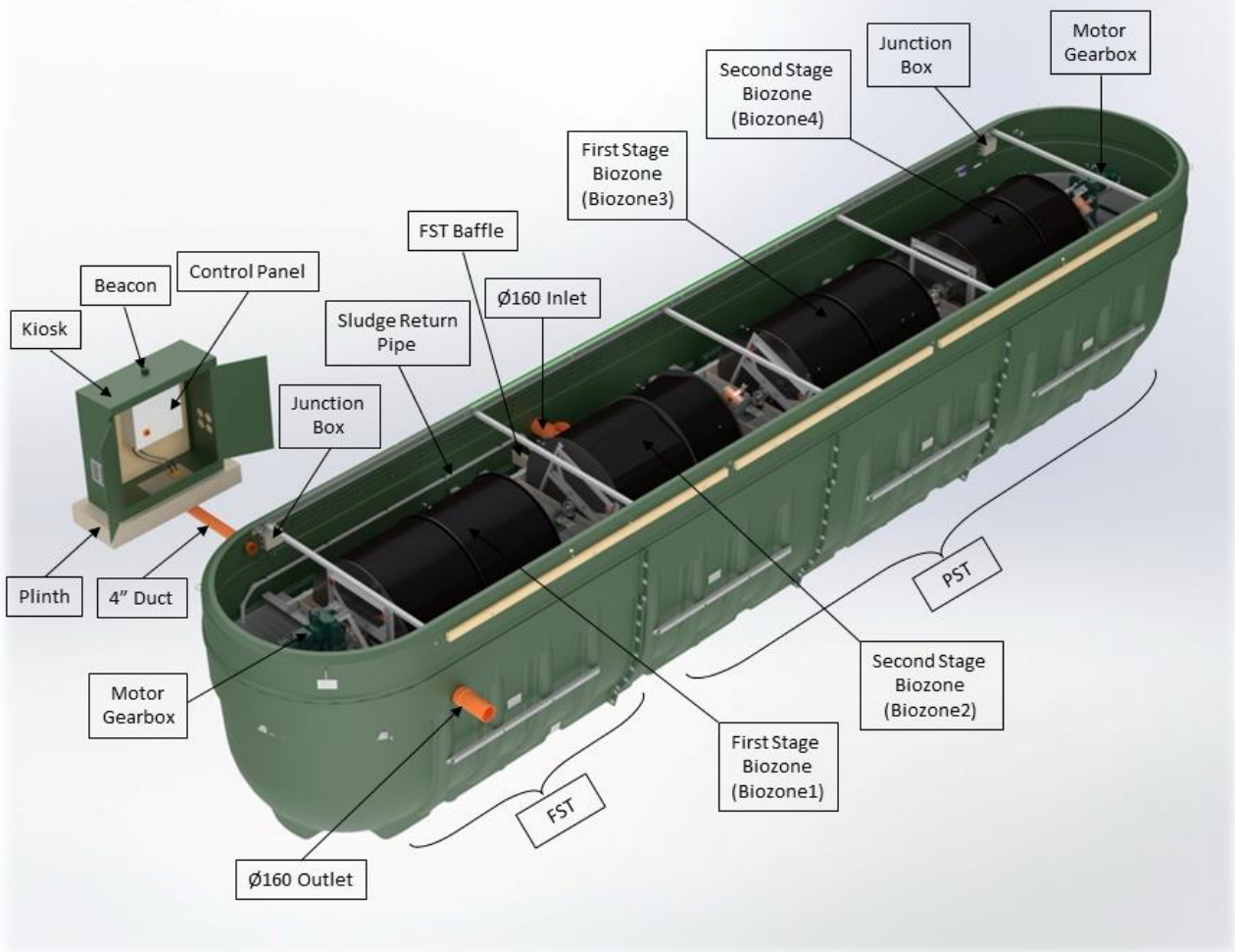

Overview

1 Introduction

Thank you for choosing a Kingspan product. This manual will help you to keep it operating efficiently over a long service life. Please read this manual thoroughly, preferably before installation.

This manual should be referred to by:

- a) The installer.
- b) The electrician.
- c) The maintenance engineer.
- d) The desludge contractor.
- e) The owner/user

These Guidelines represent Best Practice for the installation of these Kingspan BioDisc Units. Many years of specialist experience has led to the successful installation of thousands of BioDisc units. It must be noted, however, that these Guidelines are necessarily of a general nature. It is the responsibility of others to verify that they are appropriate for the specific ground conditions and in-service loads of each installation. Similarly, any information or advice given by employees or agents of Kingspan regarding the design of an installation must be verified by a qualified specialist (e.g. Civil engineering consultant).

Note;
Remove the Control Panel from the walkway inside the unit.



2 Technical Data

Note; Illustrations are schematic. Refer to General Arrangement Drawings for true dimensions and pipework orientation.

Standard – Single Piece System

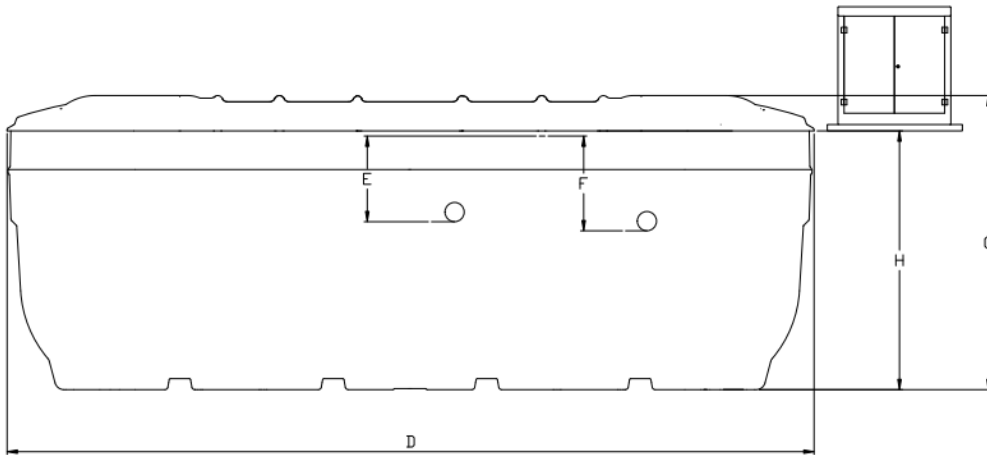

Option – Balance Tank (Airlift Fed) Two Piece System

BT Inlet Options – 500mm, 1000mm, 1500mm, 2000mm

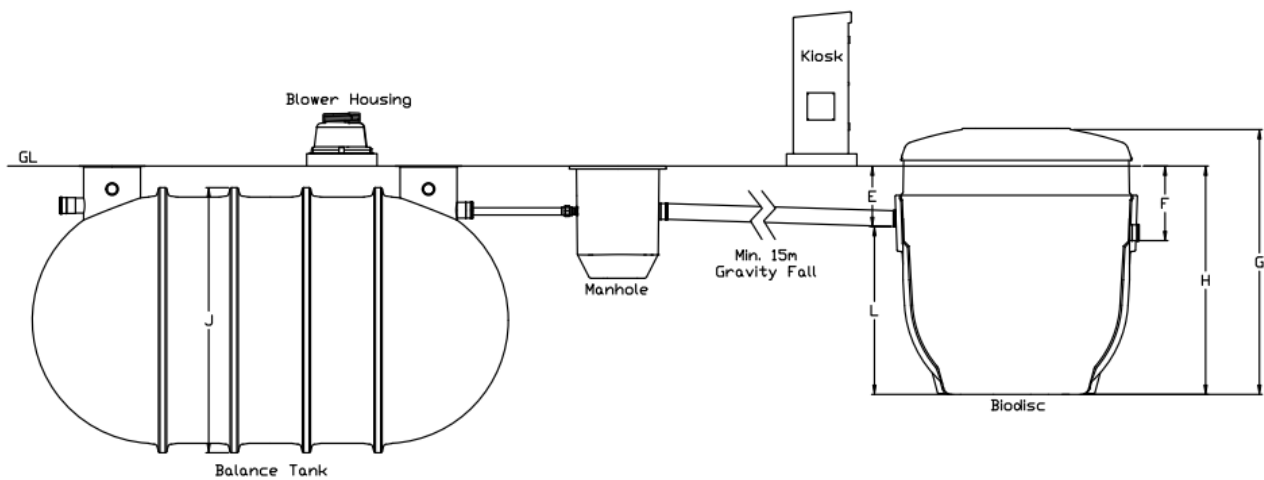

GL = Ground Level

Note;

-The **minimum discharge is 15m** by gravity from the connecting manhole to the treatment plant. Do not pump directly into BioDisc.

-For pump placement, please get in touch with Klargestær.

2.1.1 The loadings given below are representative of typical domestic housing applications for a discharge consent of 20/30/20. The sizing of sewage treatment plants requires specialised knowledge and experience. Please consult Kingspan for an assessment of your application.

2.1.2

Unit	BN	
Maximum Daily BOD (kg)	18	
Maximum Daily Flow (m³)	60	
Peak Flow Rate (m³)	7.5	
BOD (mg/l)	20	
Suspended Solids (mg/l)	30	
Ammonium NH ₄ ⁺ -N (mg/l)	20	
<u>Primary Settlement Tank</u>		
Please Refer To Klargester Sales For Applications Requiring A Primary Settlement Tank For Sizing And Dimensional Information.		
BioDisc	BN	
Inlet Invert Depth E mm	600	1000
Length D mm	13100	
Width mm	2582	
Depth Below Inlet Invert L mm	1790	
Outlet Invert Depth F mm	750	1150
Overall Height G mm	2850	3250
Height To rim cover H mm	2490	2890
Empty Weight kg	6010	6500
Standard Power Supply	1Phase - 3 Phase	
Motor Rating 1&3 Phase Watts	2 x 370	
Full Load Current Amps	1 PH / 3 PH	
	2x2.35 / 2x1.35	
Sludge Return Pump Rating Watts	250	
<u>Balance Tank</u>		
Diameter J mm	2820	

3 Handling & Storage

- 3.1.1 Care must be taken to ensure that the unit is not damaged during delivery and handling on site. If there is any damage it should be reported to the Warranty Team (028 3836 4446) within 48 hours of delivery.
- 3.1.2 The design requirements of Kingspan products will frequently mean that the centre of gravity of the unit is "offset". Care must therefore be taken to ensure that the unit is stable when lifting. Rainwater may also collect inside units, particularly if they have been stored on site prior to installation, adding weight and increasing instability. Check units before lifting and pump out any excess water.
- 3.1.3 When lifting units, use webbing slings of a suitable specification. When lifting BioDisc units the slings must be passed through the indicated channels in the base of the unit.
- 3.1.4 A suitable spreader bar should be used to ensure that the unit is stable and that loads are evenly distributed during lifting. When lifting BioDisc units the spreader bar length should be equal to the width of the BioDisc to avoid compression damage to the covers or sides of the unit.
- 3.1.5 Do not use chains. Do not use the U-bolts or horizontal beams on the BioDisc case for lifting.

- 3.1.6 Lifting equipment should be selected by taking into account the unit weight, length and the distance of lift required on site.
- 3.1.7 Kingspan Environmental accepts no responsibility for the selection of lifting equipment.
- 3.1.8 Whenever Kingspan BioDiscs are stored or moved on site, ensure that the storage location is free of rock, debris and any sharp objects, which may damage the unit. The BioDisc must be placed on ground, which is flat and level to evenly support the base of the unit.

4 Site Planning

The following points should be considered before installation of the equipment:

- 4.1.1 The discharge must have the consent of the relevant Environmental Regulator.
- 4.1.2 The installation should have Planning and Building Control approval.
- 4.1.3 Due to rising groundwater conditions in GB and Ireland, we strongly recommend that a concrete backfill is used to install the product.
- 4.1.4 Ground conditions and water table level should be assessed. If the water table will be above the base of the unit at any time of the year, adequate concrete backfill must be provided to avoid flotation. In poorly draining ground, consideration should also be given to the likelihood of flotation due to surface water collecting in the backfill. It should be borne in mind that the inlet drain trench will act as a land drain, directing surface water to the backfill around the unit.
- 4.1.5 If discharge is to a soakaway, a porosity test should be carried out in accordance with BS 6297 to assist in assessing sub-soil drainage and designing the sub-surface irrigation system.
- 4.1.6 The use of Borehole soakaways with Kingspan sewage treatment products is only acceptable when the Environment Agency discharge license allows them. Borehole soakaways are not accepted under building regs or BS6297 so it is only under special circumstances that the EA will allow such a system. Maintenance of the borehole is essential to maintain permeability.
- 4.1.7 The BioDisc system must be installed at a level, which will allow connection to the incoming drain and a free discharge at the system outlet. Effluent pumping station are available to lift the discharge to a higher level and/or pump to remote discharge points.
- 4.1.8 The unit should be installed so that the bottom lip of the cover is 65mm or more above local ground level. If the unit has to be recessed, measures must be taken to ensure that it cannot be flooded by surface water run-off.
- 4.1.9 There must be at least 1 metre of clear, level ground all around the unit to allow for routine servicing, plus adequate space to allow complete removal of the covers.
- 4.1.10 Adequate access must be provided for routine de-sludging and maintenance, including crane access. Vehicles should not be permitted within a distance equal to the depth of the unit, unless suitable structural protection is provided to the installation.
- 4.1.11 BioDisc covers are not suitable for walking on. Where necessary the BioDisc should be fenced off or otherwise protected. Maintenance access must be maintained as above.
- 4.1.12 The drainage system connected to the BioDisc must be adequately vented in accordance with the Building Regulations. The head of the drainage system should be connected to a stack pipe, open at high level, so as to draw foul air from the system and sited with consideration to prevailing wind direction. Tile vents & Air admittance valves should not be used as the sole drainage ventilation facility, but if this cannot be avoided, the BioDisc should be independently ventilated. All inspection points within the drain system should be sealed so as to enable ventilation at high level.
- 4.1.13 An adequate electrical supply must be provided, complying with current electrical regulations. The electrical details in section 2.1.1 will enable selection of suitable cable and current overload protection, taking into account the distance from the power source to the control panel and any other relevant factors. In most cases steel wire armoured (S.W.A) cable, minimum 2.5 mm² will be suitable, but this is a minimum recommendation and selection is the responsibility of the installing electrician. Although not obligatory for an installation of this type, RCD protection is suggested as an extra precaution.
- 4.1.14 Pump stations or any other associated equipment should have a separate power supply.
- 4.1.15 Proximity to a mains water hosepipe connection point is recommended, for maintenance purposes. Such a supply should be connected in accordance with water bylaws and regulations. **Never leave a hose connected and immersed in sewage.**

- 4.1.16 Installation should only be carried out by suitably qualified and experienced contractors in accordance with the Health and Safety at Work Act. Electrical work should be carried out by a qualified electrician, working to the latest edition of IEE.

5 Installation

5.1 General

- 5.1.1 When units are installed in unstable ground conditions where movement of the surrounding material and/or unit may occur, the connecting pipe work should be designed to minimise the risk of damage from differential movement of the unit(s) and/or surrounding material.
- 5.1.2 In situations where the excavation will not maintain a vertical wall, it will be necessary to support sidewalls of the excavation (E.g. with suitable trench sheets and bracing systems) to maintain a vertical wall from the bottom to the top of the excavation. DO NOT completely remove the shoring system until after the backfilling is complete, but before the concrete fully hardens.
- 5.1.3 In areas where the water table is above the bottom of the excavation and/or the excavation is liable to flood, the excavation should be de-watered, using suitable pumping equipment, until the installation is complete. In such conditions it may be advisable to line the excavation with polythene sheeting, to prevent cement being washed out of the concrete surround/base.
- 5.1.4 During installation care must be taken to ensure that the body of the unit is uniformly supported so that point loads through the unit are avoided.
- 5.1.5 Refer to the drawings attached for dimensions of units.
- 5.1.6 The Concrete Specification is not a site-specific installation design.

GENERAL CONCRETE SPECIFICATION IN ACCORDANCE WITH BS EN 206-1 (BS 8500-1)	
TYPE OF MIX	(DC) DESIGN
PERMITTED TYPE OF CEMENT	BS 12 (OPC): BS 12 (RHPC): BS 4027 (SRPC)
PERMITTED TYPE OF AGGREGATE ((coarse & fine)	BS 882
NOMINAL MAXIMUM SIZE OF AGGREGATE	20 mm
GRADES: C25 /30 C25 /30 C16 /20	REINFORCED & ABOVE GROUND WITH HOLDING DOWN BOLTS REINFORCED (EG. FOR HIGH WATER TABLE) UNREINFORCED (NORMAL CONDITIONS)
MINIMUM CEMENT CONTENT	C30 270 - 280 Kg/M ³ C20 220 - 230 Kg/M ³
SLUMP CLASS	S1 (25mm)
RATE OF SAMPLING	READY MIX CONCRETE SHOULD BE SUPPLIED COMPLETE WITH APPROPRIATE DELIVERY TICKET IN ACCORDANCE WITH BS EN 12350-1
NOTE: STANDARD MIXES SHOULD NOT BE USED WHERE SULPHATES OR OTHER AGGRESSIVE CHEMICALS EXIST IN GROUND WATER	

5.2 BioDisc Installation

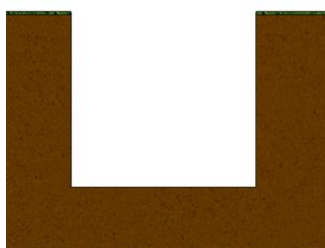

Stage 1

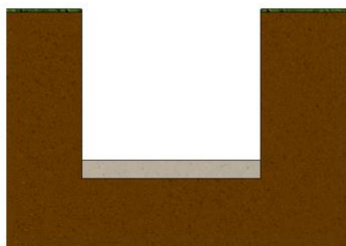

Stage 2

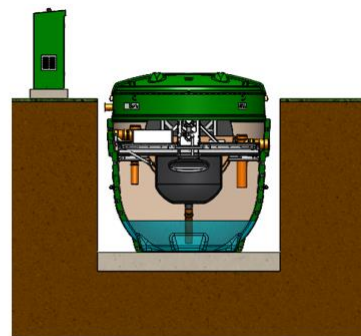

Stage 3

<p>Excavate a hole of sufficient length and width to accommodate the unit and a minimum of 200mm concrete surround and to a depth, which allows for the burial depth of the unit plus a minimum 300mm thick concrete base.</p> <p>The Site Engineer (by others) is required to design the reinforced concrete backfill to alleviate any pressure on the tank from factors such as a high-water table, lateral ground pressure, heavy traffic loading, etc.</p>	<p>Construct a suitable concrete base slab, a minimum of 300mm thick, appropriate to site conditions. In wet or unstable ground conditions it may be necessary to lay a hard-core sub-base. Ensure that the slab is flat and level. Allow the slab to set sufficiently to support the installed load.</p> <p>Ensure that the slab is free of any stones or other material, which could damage the unit. Lower the unit onto the slab using suitable webbing slings and lifting equipment.</p> <p>A structural base (by others) is required when installing in sandy or high-water table conditions.</p>	<p>Remove the package attached to the outside of the unit (contains Installation Guidelines and cover key). Undo the locks and fold back the end covers before lifting them off. Unlock and remove the centre covers. Remove the Control Panel from the walkway inside the unit. Check that the inlet and outlet orientation are correct and that the unit is level. Ensure the unit is level to within $\pm 5\text{mm}$ from side to side, measured at the walkway on either side of the rotor. If necessary, lift the unit off the base and apply concrete to level it.</p> <p>Do not use the top flange of the BioDisc for levelling, as manufacturing tolerances may cause it to not be parallel with the rotor shaft.</p>
---	--	--

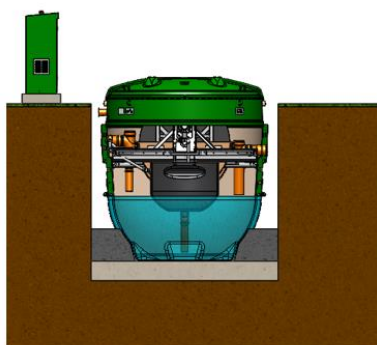

Stage 4

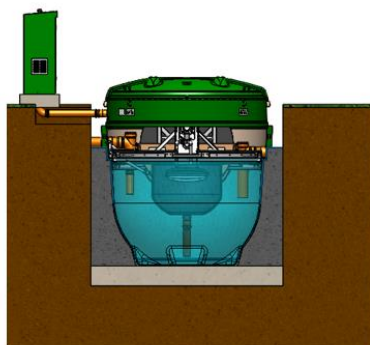

Stage 5

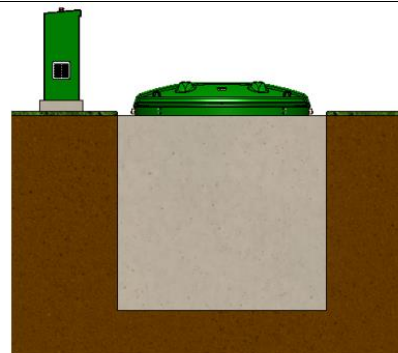

Stage 6

<p>Pour no more than 1 metre depth of water into both primary (inlet) chambers and the final (outlet) chamber ensuring that there is never more than 250mm difference in water level between any of the sections.</p> <p>Place concrete backfill to approximately 500mm depth around the unit ensuring good compaction to avoid voids. Do not use vibrating pokers.</p>	<p>Continue backfilling with concrete to just below the level of the inlet spigot. Keep the concrete at an even level all-round the unit, compacting in layers. As backfilling progresses keep the ballast water level inside the unit 250-500mm above the concrete backfill level, but do not attempt to fill the unit with water above the outlet level.</p> <p>Remove blanking cap from the cable duct at the outlet end of the unit.</p>	<p>Continue to backfill, with concrete up to ground level. Do not use sand or granular material. The finished surface should be 65 mm (minimum) lower than the lip of the cover.</p> <p>It is essential that the unit levels are checked regularly throughout the installation process. Should the unit become out of level, immediate remedial action is advised, to maintain the unit within the levels stated under stage 3.</p>
---	--	--

Important: Refer to Front Page regarding delayed electrical installation.

5.3 Control Panel – Installation

- 5.3.1 The control panel is supplied fixed to the pedestrian walkway at the outlet end of the unit, cut cable ties to remove.
- 5.3.2 The control panel is suitable for internal or external wall mounting, with volt-free contacts for an optional beacon or telemetry. Kiosks are available as an option on request.
- 5.3.3 It is important that the control panel is situated in an accessible location for servicing and maintenance.
- 5.3.4 The panel key is in the protective bag on the front of the panel.
- 5.3.5 Seal the duct in the kiosk to prevent odour coming from the unit.

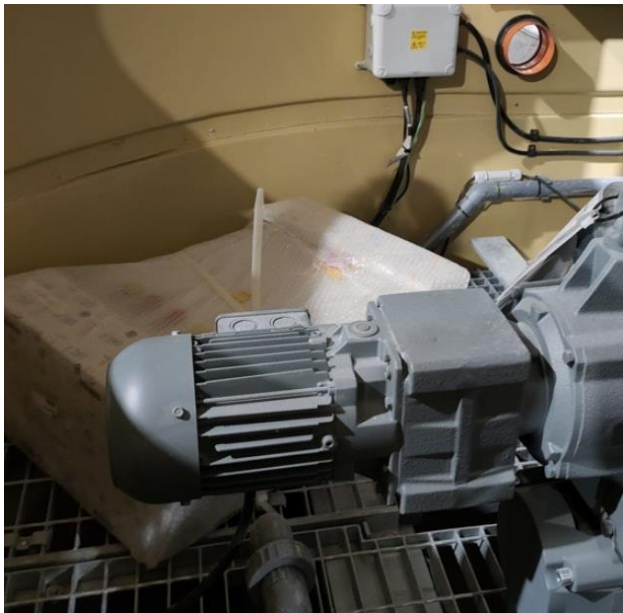

5.4 Control Panel - Connection

- 5.4.1 It is necessary to supply (by others) SWA cable to connect the control panel with the internal junction box inside the unit.
- 5.4.2 The gearbox, loss of rotation alarm and sludge return pump are all **pre-wired** into the internal junction box within the unit.

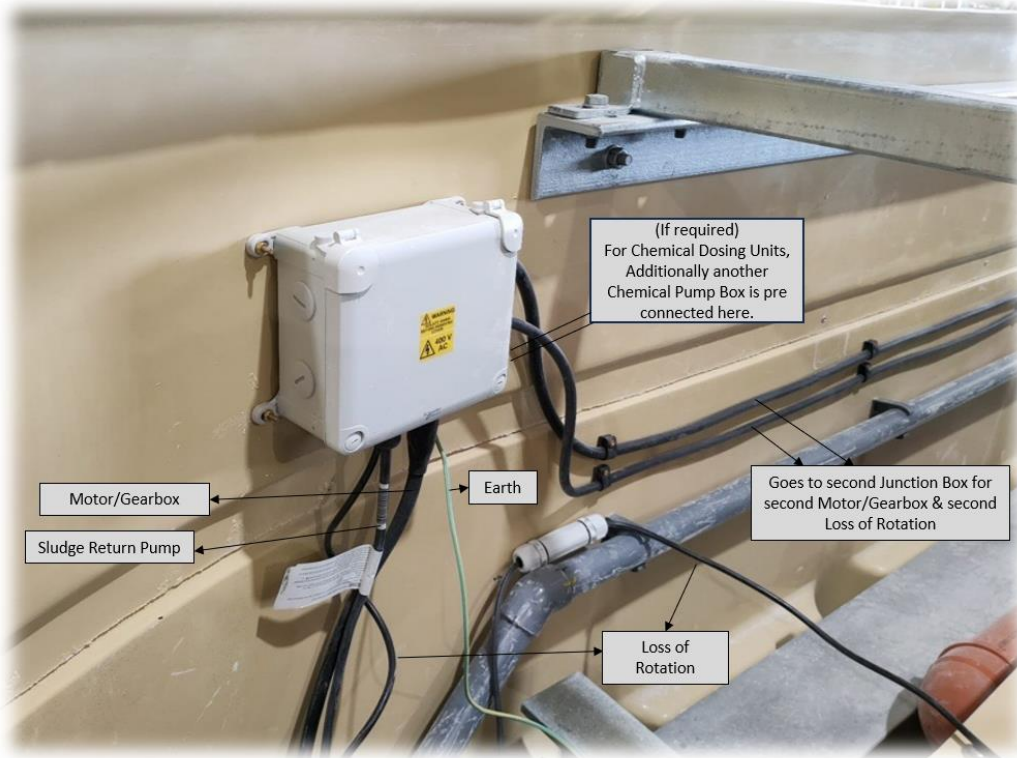

- 5.4.3 The SWA cable connecting the control panel and internal junction box must be ducted through the 4" port at the outlet end of the unit.



5.4.4 Refer to the wiring diagram inside the panel for connection details.

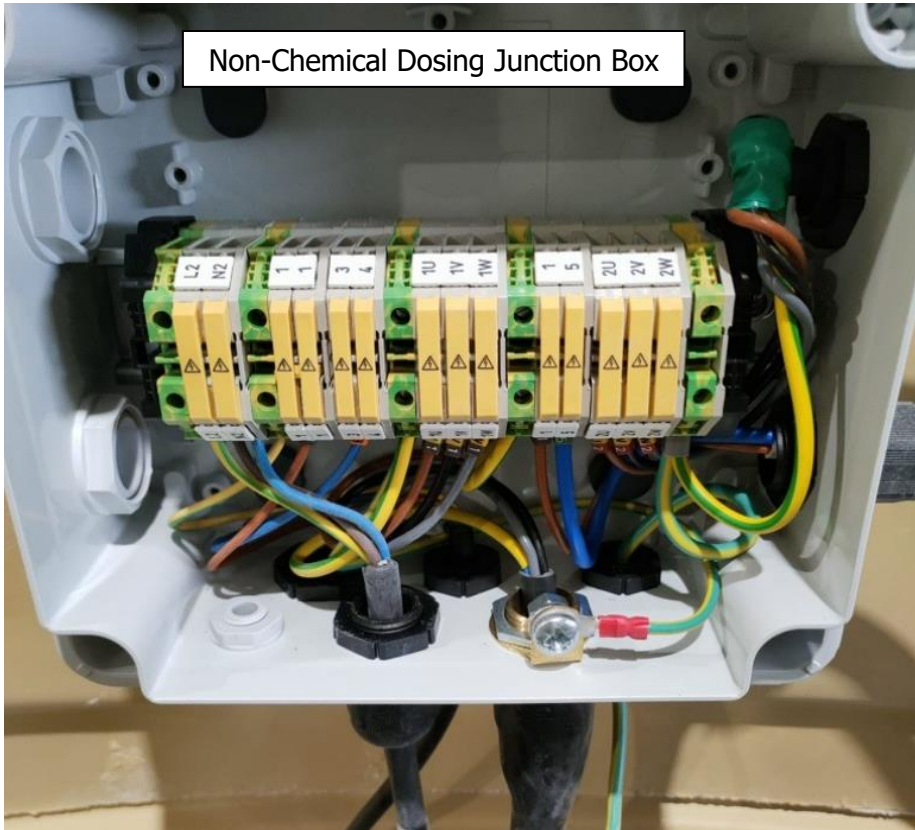

5.4.5 Inlet Hose from Chemical Container (by others) must be passed through the 4" port for chemical dosing units.

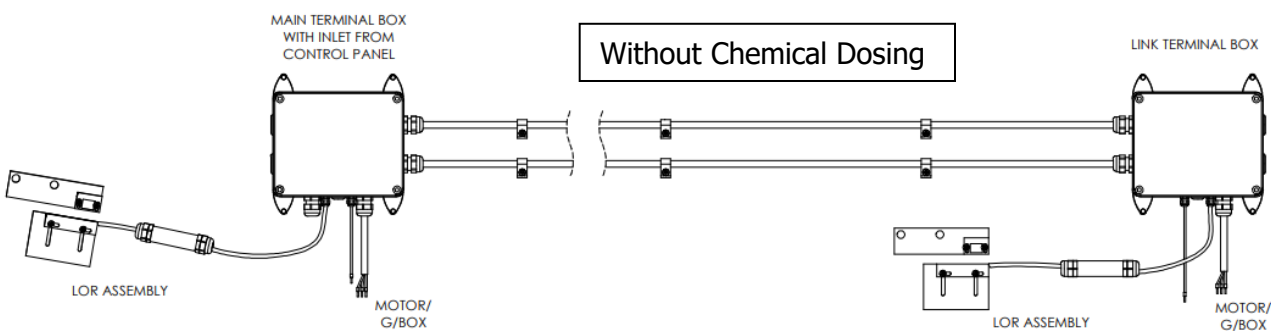
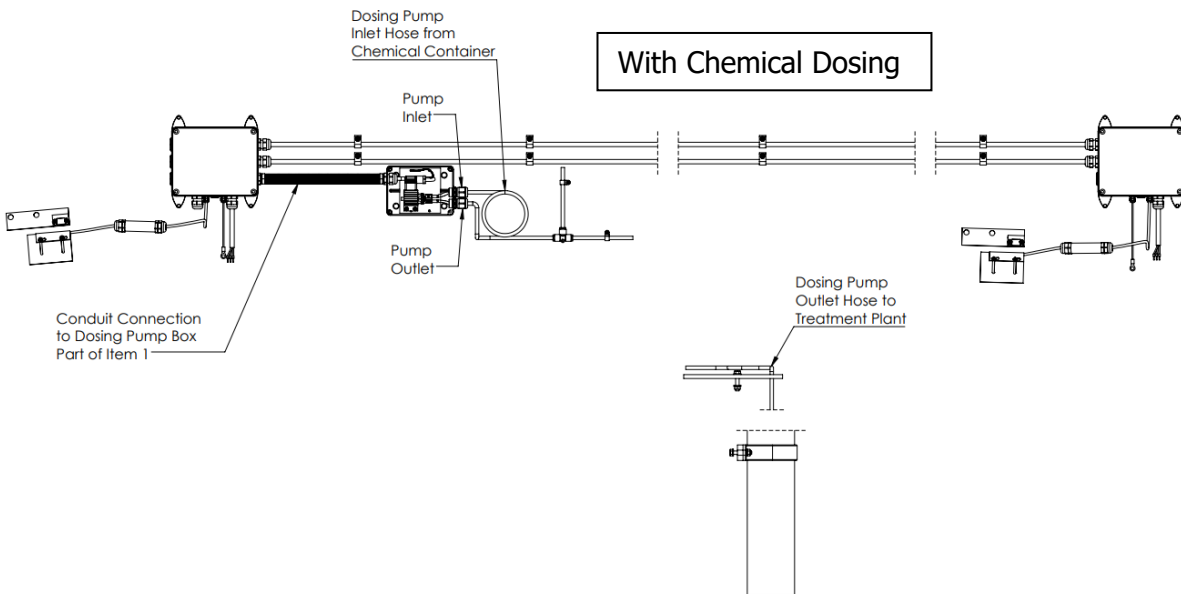

5.4.6 Control Panel & Loom Wiring Drawings

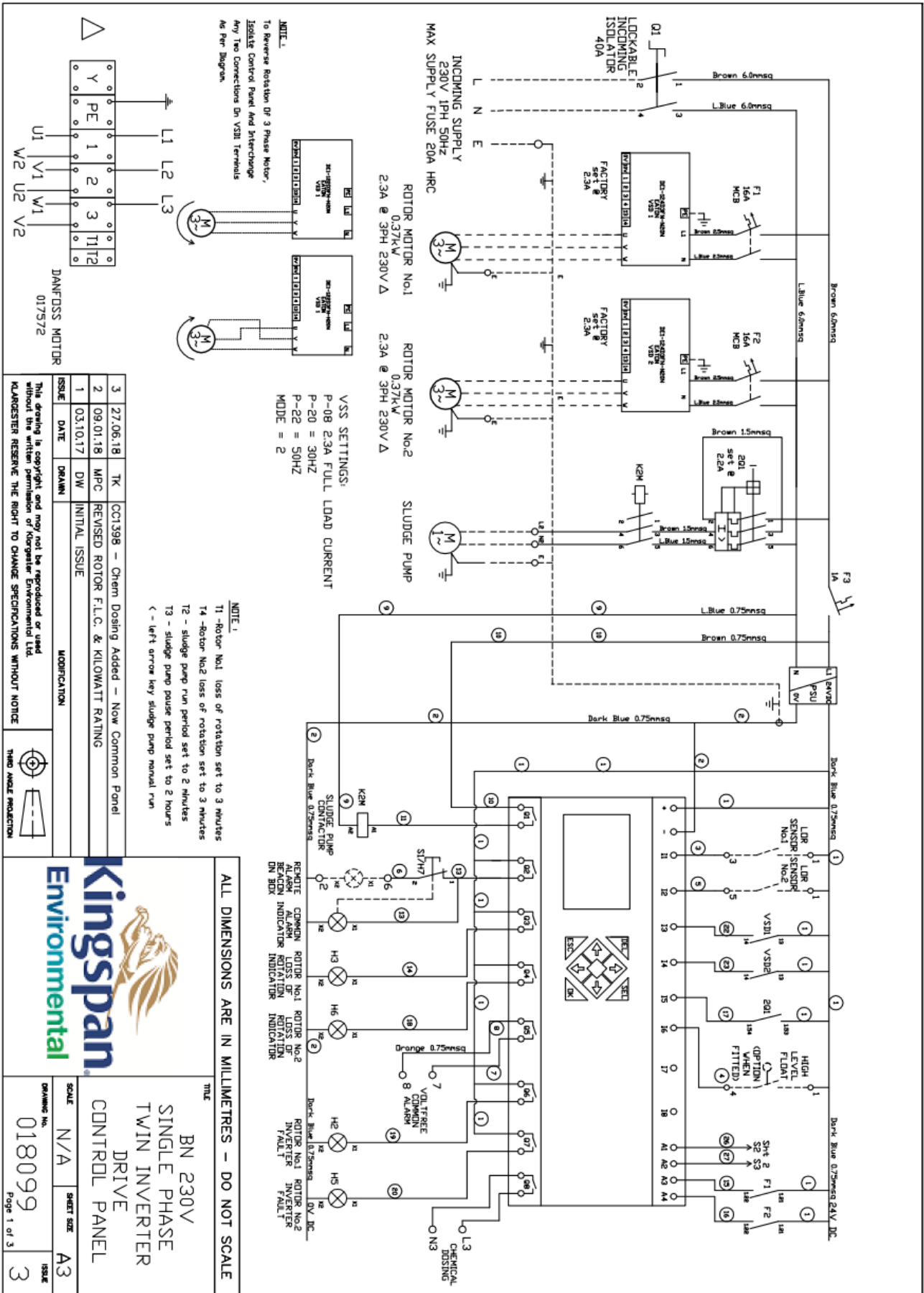

BN 230V Single Phase Control Panel – Drawing 1

Note; We recommend that the incoming supply be 40A due to power outage.

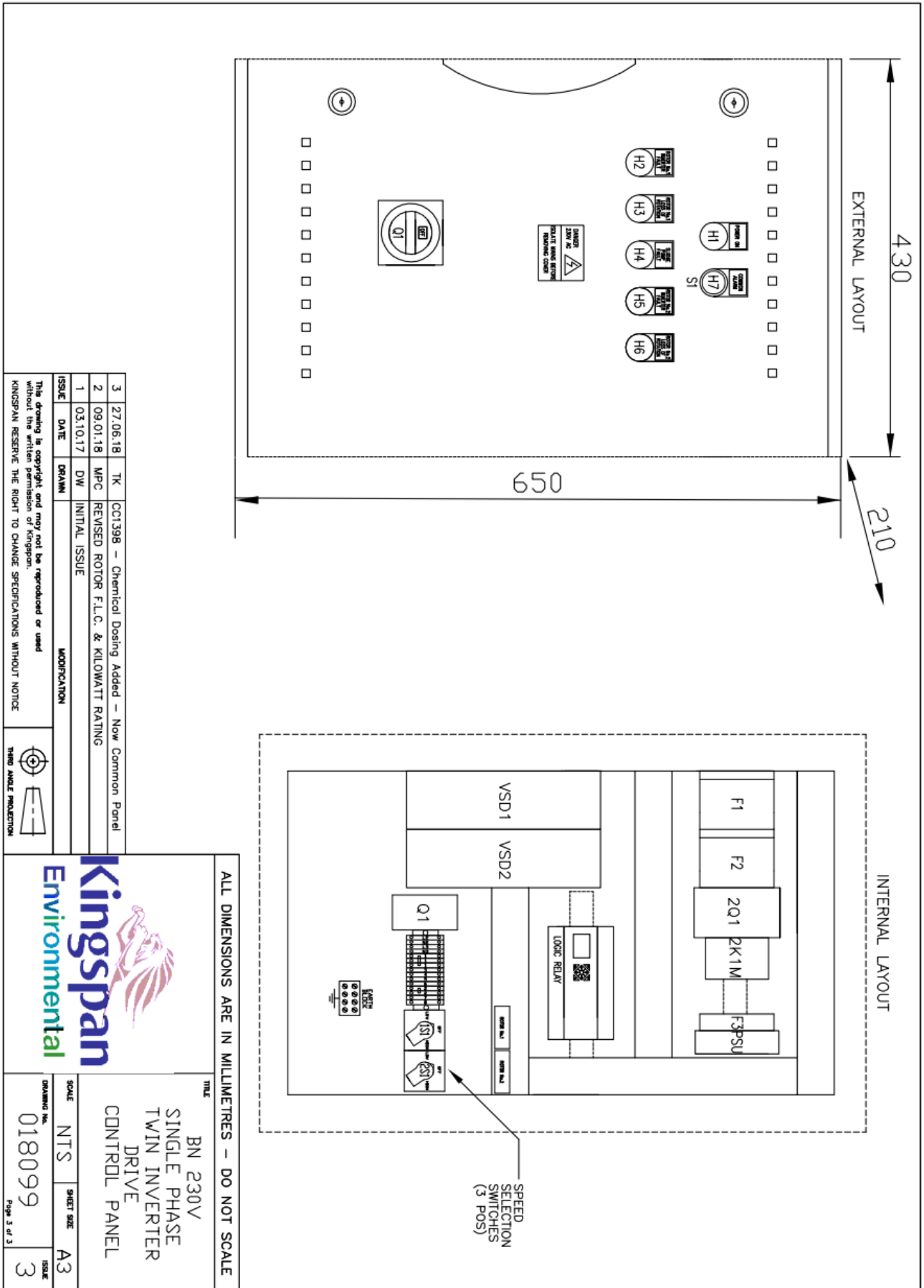

BN 230V Single Phase Control Panel – Drawing 3

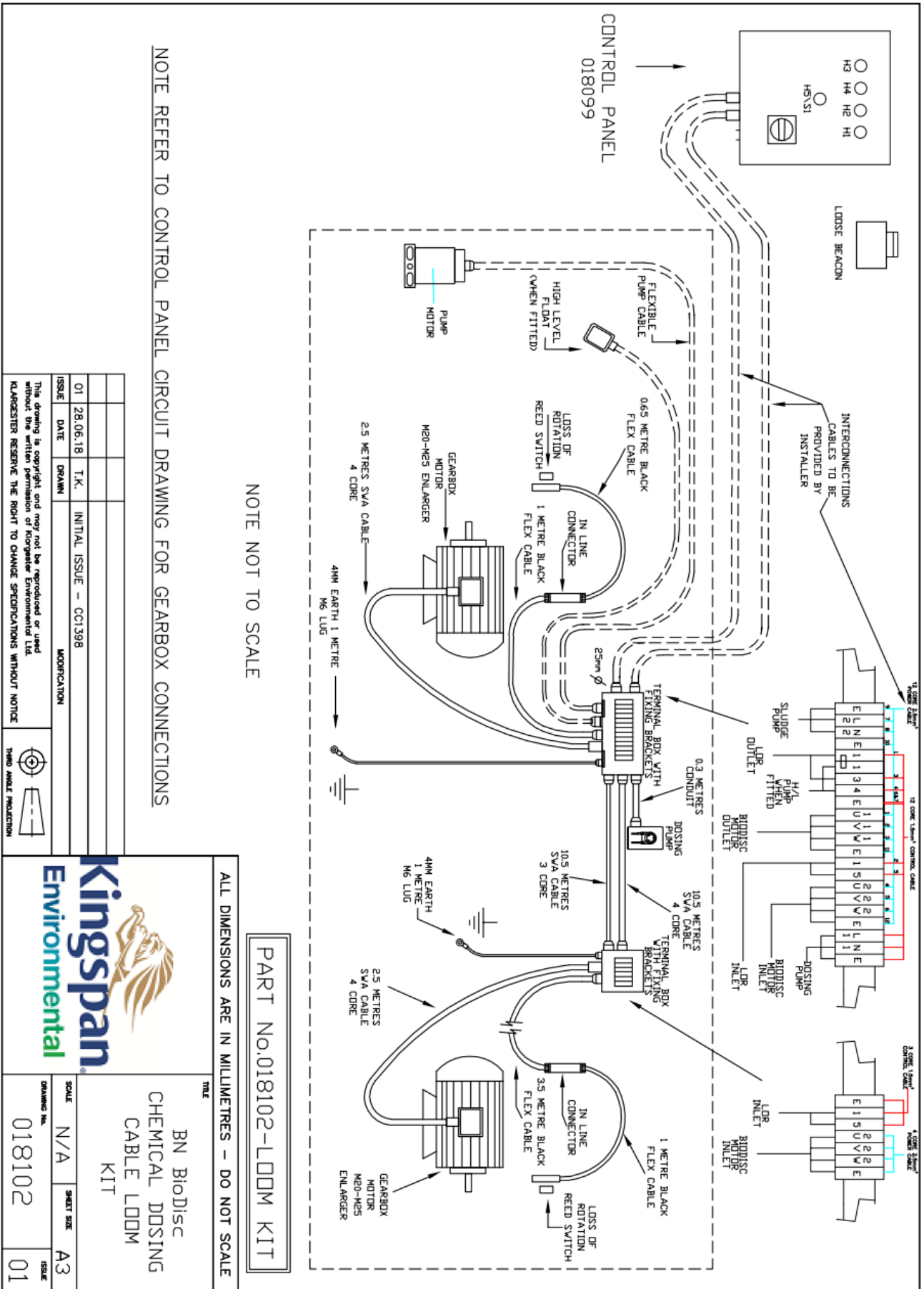

ISSUE	DATE	DRAWN	MODIFICATION
01	28.06.18	T.K.	INITIAL ISSUE – CC1398

This drawing is copyright, and may not be reproduced or used without the written permission of Kingspan Environmental Ltd. KINGSPAN RESERVE THE RIGHT TO CHANGE SPECIFICATIONS WITHOUT NOTICE

Kingspan Environmental

BN BioDisc
CHEMICAL DOSING
CABLE LDDM
KIT

SCALE N/A **SHEET SIZE** A3 **ISSUE** 01

BN BioDisc Loom Chemical Dosing

5.5 Ancillary Equipment

- 5.5.1 Ancillary items should be installed in accordance with the Installation Guide supplied e.g.
- Primary Settlement Tank
 - Sewage Pump Station
 - Effluent Pump Station
 - Sample Chamber
 - Grease Trap

6 Start Up

- 6.1.1 Every care is taken to ensure that all mechanical components are correctly fitted, adjusted and lubricated prior to leaving the factory. However, subsequent handling during transportation and installation may result in the movement of components and a subsequent need to re-adjust prior to starting the unit. If, on inspection, you consider that any components require adjustment, please contact Kingspan.
- 6.1.2 Once the unit has been installed it should be left filled with water. Please switch on the motor, following the procedure below and leave the unit running, even if there is no sewage being fed into the plant. **If the unit has been installed with no operational power supply, then remove the motor/gearbox unit and store it in a dry or heated environment until such time as the unit is ready for permanent operation.** Kingspan or an experienced contractor should then replace the motor gearbox unit.
- 6.1.3 We recommend that Kingspan should commission the system: details on request.
- 6.1.4 Where circumstances dictate an immediate start-up the following basic procedures should be carried out.
- 6.1.5 Check that the Primary Settlement Tank (where applicable) and the BioDisc are full of water to their outlet levels.
- 6.1.6 Check that the power supply is connected to the control panel. Check that all electrical components and conductors are earthed.

6.2 Automatic grease cartridges

- 6.2.1 The shaft roller bearings are fitted with pressurised grease cartridges. These should be activated before the unit is started.
- 6.2.2 **Turn the control knob and it's linked dial until the figure 6 is against the arrow on the casing, as opposite (this will give a lubrication period of 12 months at the temperature in the BioDisc).**
- 6.2.3 Depress the red button. This secures the setting and releases the control knob from dial.
- 6.2.4 Rotate the knob clockwise to activate the unit. **Note: Grease cartridges must be changed every 12 months.**



6.3 Optional Pump Station

- 6.3.1 Check that the pumps have been installed and wired to the Pump Control Panel.
- 6.3.2 The pumps should be set to pump little and often in order to prevent excessive loading on the BioDisc.
- 6.3.3 Check the setting of the high-level float in the pump chamber. This must be set to operate the pumps so as not to exceed the balancing volume of the unit. To ensure this the float must operate below the level of the inlet of the unit. Ensure that the float(s) can operate freely without risk of entanglement. Check that the Pump Control Panel timer is set correctly, as shown on the wiring diagram.

6.4 BioDisc

- 6.4.1 Check that the BioDisc is in order, with no obvious damage or misalignment of parts. If any possible problems are discovered, contact Kingspan.
- 6.4.2 Check that all electrical components: Drive Motors, Sludge Return Pump and LOR Alarm sensors, are connected to the Control Panel.
- 6.4.3 Check that the Sludge Return Timer in the BioDisc Control Panel is set correctly, as indicated on the wiring diagram.

6.5 Switch-on

- 6.5.1 Open the BioDisc control panel, check that all circuit breakers are in the “on” position and switch on the main isolator switch. Close and lock the panel. Immediately upon switching on the sludge return pump should start and run for the set time.
- 6.5.2 Open the Pump Control Panel (where installed), check that all circuit breakers are in the “on” position and switch on the main isolator switch. Close and lock the panel. Immediately upon switching on the isolator, one of the pumps may start and run for the set time.

6.6 Process Initiation

- 6.6.1 During installation, the unit will have been filled with water to prevent flotation in the concrete surround. Allow sewage to enter the unit, this will gradually displace the clean water used during installation.
- 6.6.2 The colonisation by micro-organisms will commence naturally and a full operating biomass will establish itself on the discs in 4-8 weeks, depending on individual site circumstances.

7 Operation

- 7.1.1 The biological treatment process of your BioDisc is self-regulating and it requires no specialised operational knowledge, but it is important that you are aware of the following points.
- 7.1.2 Your BioDisc system uses colonies of live natural micro-organisms (biomass), to break down the pollutants in the sewage. Many chemicals used in households and commercial establishments can inhibit or kill these micro-organisms; particularly if used in excessive amounts.
- 7.1.3 Bear in mind that treatment plants serving small populations do not have the benefit of dilution that occurs at a large sewage works. A bottle of bleach tipped down the toilet in Birmingham would be virtually lost amongst the millions of gallons of sewage arriving at the city's treatment works; a bottle of bleach in a plant serving a hotel could be a lethal dose for the biomass.
- 7.1.4 If the biomass is damaged, it will usually recover over time. But in the meanwhile, one of the more obvious symptoms is an unpleasant smell, so it is in the users interest to avoid this.
- 7.1.5 Generally speaking, all common household cleaning fluids are acceptable, provided they are used in accordance with the makers instructions and stipulated concentrations. The following “Do’s and Don’ts” includes the most common household chemicals, but it is not an exhaustive list, and the golden rule is "If in doubt - leave it out."
- 7.1.6 Bear in mind too that it isn't only the toilet that is connected to the treatment plant; anything that goes down the sink, bath etc. also ends up there.

7.2 Do's and Don'ts

7.2.1 Washing machine and dishwasher detergents, washing up liquids:

These are generally all right to use in the normal concentrations and usage found in domestic housing applications. All commercial applications are individually assessed before installation for their laundry load. Please contact Kingspan for advice if any changes are contemplated e.g. addition of extra laundry facilities.

7.2.2 Floor cleaners, disinfectants and bleaches:

These are safe to use in accordance with the makers recommendations and in the minimum necessary concentration. Do not pour neat disinfectant or bleach down sinks or outside gullies. If these are smelly it usually indicates a build-up of decaying material or a plumbing problem and should be dealt with accordingly.

7.2.3 Nappy disinfectants and bottle sterilising fluids E.g. Milton:

When disposing of the used fluid, ensure that it is well diluted with water. The easiest way of doing this is usually to flush it away down the toilet.

7.2.4 Waste disposal units:

These do not inhibit the biomass, but, depending on use, they can present the treatment plant with considerable extra load. This can result in the treatment process becoming unbalanced, leading to problems. Much better to compost your vegetable peelings etc - it's cheaper and environmentally friendly.

7.2.5 Beer and wine making.

This presents a similar problem to waste disposal units. The BioDisc must work as hard to treat one pint of beer tipped down the drain as it does to treat all the normal waste produced by one person in 24 hours. See also the notes above regarding sterilising fluids. **Beer liner cleaner must not be discharged into the BioDisc.**

7.2.6 THE FOLLOWING MUST NOT BE DISCHARGED INTO THE DRAINS

- **Motor oil, grease, anti-freeze, brake fluid etc.**
- **Cooking oil and fat.**
- **Weed-killers, insecticides, fungicides and other gardening chemicals.**
- **Paint, thinners, white spirit, turpentine, creosote etc.**
- **Medicines.** Take unused medicines to a pharmacist for safe disposal.
- **Photographic developing fluids.**
- **Nappies, sanitary towels, rags, soft toys, tennis balls etc.**

This may seem obvious, but it is amazing what gets flushed down the loo from time to time. Although such items are not directly damaging to the biomass they can cause problems, not the least of which is simple blockage of the drains.

Even so-called disposable nappies and sanitary towels often do not degrade fully in the treatment plant and can lead to malfunction, so it is best to dispose of them by other means.

7.3 Automatic Restart

- 7.3.1 BioDiscs are designed to re-start automatically when power is resumed, but the re-start may not succeed in some circumstances, such as extended power cuts. This will cause the alarm to activate when power is re-established after power cuts, check that the rotor is turning correctly. In the event of any difficulties, contact Kingspan.

8 Running Checks

8.1.1 Check that the rotors are running smoothly in the correct direction of rotation (see section 8.1.2) and are not contacting any part of the fixed structure.

8.1.2 Check that the forward feed buckets are discharging correctly from both first to second stage Biozones.

8.2 Loss of Rotation Alarm

8.2.1 Check operation of the Loss of Rotation (LOR) Alarms as follows:

8.2.1.1 Open the Control Panel and switch off the drive motor circuit breakers. After a delay of 2-3 minutes the alarm should activate.

8.2.1.2 Push the "Beacon Off" button on the front of the Control Panel. The alarm beacon should stop flashing and the red indicator light on the panel front should remain illuminated.

8.2.1.3 Switch on the drive motor circuit breakers and close the Control Panel. The alarm should cease after approximately one minute.

8.2.1.4 Depress and release the "Beacon Off" button to reset it.

8.2.2 Malfunctioning of the LOR Alarm does not prevent operation of the BioDisc System, but it should be reported to your maintenance engineer for early rectification.

8.3 Customer Checks

8.3.1 The following periodic checks should be carried out monthly. Your attention is specifically drawn to the Health and Safety section of this manual.

8.3.1.1 Visually check the general condition of the plant and listen for any unusual noises. Report any aspects of concern to your maintenance engineer.

8.3.1.2 Check the appearance of the Biomass. It should be light grey to grey at both first banks, gradually changing to brown in both second stages and dark brown at the drive end of each second stage. If the growth is excessively thick and the colour predominantly grey throughout, an overload condition is indicated.

8.3.1.3 Visually check that all fixings are secure.

8.3.1.4 Clear any debris from inlet and outlet pipes.

8.3.1.5 Check dosing buckets and transfer pipes for any build-up of debris. Clean, if required, using a stiff bristled brush.

8.3.1.6 Check the Loss of Rotation Warning Devices for correct operation (see section 8.2). If the alarm does not operate properly, contact your maintenance engineer.

9 Desludging and Maintenance

9.1.1 These are vital to the plant's ongoing operation and should be carried out in accordance with the guidelines in this manual.

9.1.2 Mechanical and electrical maintenance must be performed by properly trained engineers, with reference to the appropriate Maintenance Manual. Kingspan offer a range of maintenance packages, details on request.

9.1.3 Kingspan BioDiscs are designed and engineered for the minimum possible maintenance requirements, consistent with proper performance. Nevertheless, it is important that routine preventive electro/mechanical maintenance and de-sludging are carried out at the appropriate intervals by suitably qualified persons.

9.1.4 Kingspan offer various levels of contract maintenance of all BioDisc Systems through Kingspan Environmental Services who can be contacted on 0844 846 0500.

9.2 Sludge Removal

- 9.2.1 Refer to the illustration below for recommended de-sludge positions. (Note: Illustration is typical; individual units may vary).

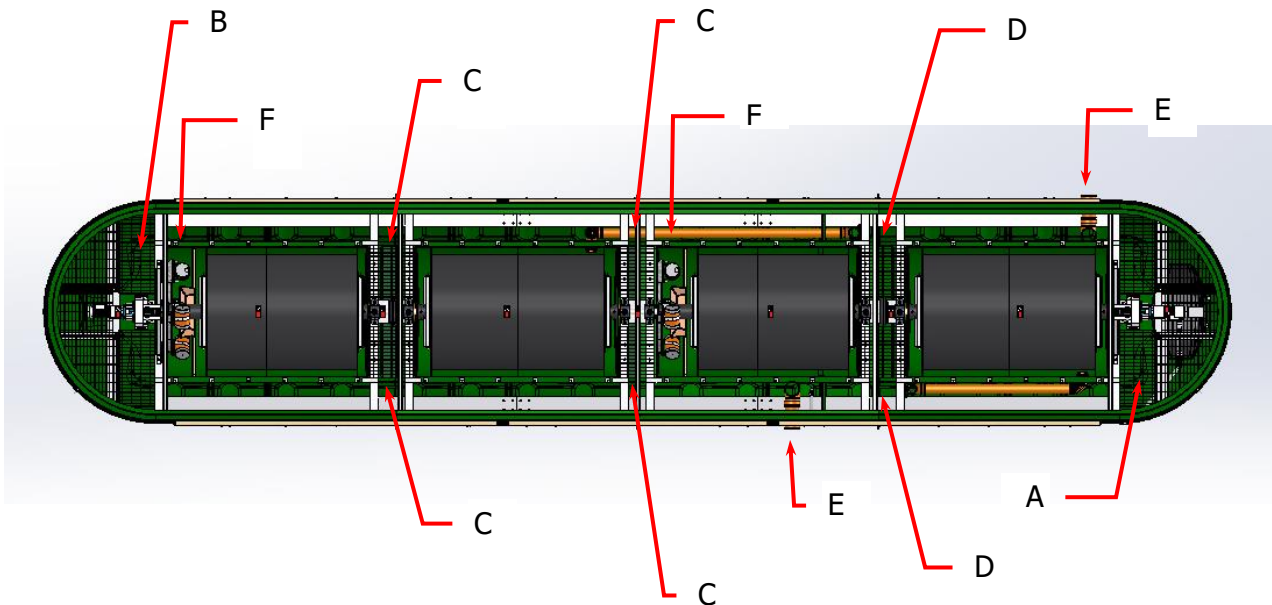

- 9.2.2 Isolate power to the BioDisc (and Pump Station if applicable) at the Control Panel(s).
- 9.2.3 Undo the BioDisc cover latches and fold back the hinged cover sections as required to gain access. Alternatively, the covers can be completely removed if wished. Hinged sections should be folded back before lifting off.
- 9.2.4 Remove any surface scum from the Final Settlement Tank [A]. The steel mesh may be removed for access if required. Lower the hose to the bottom of the tank and remove any settled sludge. Also, de-sludge at points [D] on either side of the rotors and along the length to prevent 'rat-holing'. The steel mesh over points [D] may be removed for access if required. Replace any removed steel mesh.
- 9.2.5 Remove surface scum from the BioDisc Primary Settlement Zone at point [B] and de-sludge at points [C] on either side of the rotors. De-sludge along the length of the rotors to prevent 'rat-holing'. The steel mesh over points [B] and [C] may be removed for access if required.
- 9.2.6 **Note:** While de-sludging ensure that there is never more than 250mm difference in water levels between points [A] and [C].
- 9.2.7 **DO NOT** attempt to remove any liquid from any Rotor Section.
- 9.2.8 **DO NOT** attempt to clean off the gelatinous growth on the rotors.
- 9.2.9 Ensure that the BioDisc inlet and outlet pipes [E] and the Forward Feed Buckets [F] are free of debris.
- 9.2.10 Ensure that all safety meshes are replaced, then close and lock the BioDisc covers.
- 9.2.11 Units with separate Primary Tank only - Remove the covers from Primary Settlement Tank. Remove any surface scum in the Primary Settlement Tank, then lower the hose into the bottom of the tank and completely remove settled sludge. It may be necessary to empty the tank completely to ensure full sludge removal. Ensure that the inlet and outlet pipes are clear of debris, and then replace the covers.
- 9.2.12 All units - Re-connect the power supply. Wait for two minutes. If the alarm on the control Panel does not activate, this indicates that the Rotor has successfully re-started. If the alarm activates, switch off the power at the Control Panel and immediately switch on again. If the alarm continues to activate, isolate the power supply and notify the plant owner so that the problem can be investigated.

9.3 Desludge Volumes

- 9.3.1 The minimum volumes shown here are those which can be anticipated under full loading at the de-sludge period indicated. If the system is not loaded to full capacity, the de-sludge period and volumes removed may be adjusted, but it is essential that a) sludge is not allowed to accumulate to the detriment of the process and b) all settled sludge and floating matter are removed at each de-sludge visit.

UNIT	De-sludge Period	BioDisc Primary Settlement Zone	BioDisc Final Settlement Zone
BN	Approx. 3 months	29,150 (6,412)	14,300 (3146)

Note: Volume is in litres (gallons below in brackets)

10 Warranty

Taken from 'Kingspan's Terms & Conditions of Sale'

The company will replace or, at its option, properly repair without charge any goods which are found to be defective and which cause failure in normal circumstances of use within a period of twelve months from the date of delivery.

This warranty is conditional upon:

- (a) the Buyer notifying the Company of any claim within Seven days of the failure becoming discernible.
- (b) the Company being allowed a reasonable opportunity to inspect the goods so as to confirm that they are defective.
- (c) the goods not having been modified, mishandled or misused and being used strictly in accordance with any relevant instructions issued by the Company.

The Company's liability under this Clause is limited to the repair or replacement of the defective goods, and does not cover costs of transport, installation or associated site costs, if applicable.

The Company's liability to replace or repair the goods is in lieu of and excludes all other warranties and conditions, and in particular (but without limitation) the Company shall have no liability of any kind for consequential loss or damage.

For any further advice, please contact the Warranty department on 028 3836 4446.

A Warranty Form is included in this package, to register your unit for Warranty. Please complete ALL sections of the Form, and return it at your earliest convenience.

Also within this package is a Notice, describing the necessary maintenance of the plant in use. This should be fixed within the building.

11 Notice



KINGSPAN BioDisc ®

The foul drainage from this property discharges into a package treatment works.

Maintenance is required, the frequency of which depends upon the model installed, its use and its application. Please consult your owner's pack.

* BN BioDisc requires routine maintenance and Desludging at 3 months intervals.

Maintenance and Desludging should be carried out by the owner in accordance with the Manufactures instructions.

THE OWNER OF THE PROPERTY IS LEGALLY RESPONSIBLE FOR ENSURING THAT THE SYSTEM DOES NOT CAUSE POLLUTION, A HEALTH HAZARD OR A NUISANCE.

We recommend that a separate log is kept of all maintenance and service visits, the log should detail the date and any action taken, e.g. Regular maintenance service, breakdown visit, desludge volume removed, parts replaced.

This notice should be fixed by the owner within the building alerting current and future owners to the maintenance requirement. (Building regulation H2 (1.57))

Please contact Kingspan Water & Energy Services on 0333 240 6868, to arrange a maintenance service or to request replacement operating instructions. It would be helpful if you provide your equipment serial number.