

HEALTH & SAFETY SAFE SYSTEM OF WORKS

CONSITNG OF
METHOD STATEMENT, RISK ASSESSMENT, WORKS PLAN
FOR
COPART CHESTER, SANDYCROFT

Method Statement Title:			
Proposed Drainage Outfall Pipe Construction Beneath Existing Flood Bund			
Method Statement No.:	MS-CCS-001	Revision No.:	01
Prepared by:	Name: Luke Linehan	Signed 	Date: 29.05.2025
Reviewed by:	Name: Kevin Culhane	Signed:	Date: 29.05.2205
Revision Detail:			
Revision No.:	Revision Detail & Issue Status:	Completed by:	Issue Date:
01	First Issue- For Review & Approval	Luke Linehan	29.05.2025
<p>NOTE: All REVISIONS completed will be <u>UNDERLINED</u> to highlight and show changes made after first issue. Where DELETION required, double strike through [e.g. text no longer required].</p> <p>NOTE: Where updating a previously revised document, convert previous revisions <u>UNDERLINED</u> back to NORMAL TEXT and DELETE text that was previously double struck through;</p>			

HEALTH AND SAFETY

METHOD STATEMENT

PART ONE:			
Method Statement Details:			
Project Name & No.:	Copart Sandycroft – MYCO-001	Project Manager:	TBC
Project Address:	Land East Adjacent to Copart, Sandycroft, Flintshire, CH5 2QZ		
Method Statement Title:	Proposed Drainage Outfall Pipe Construction Beneath Existing Flood Bund		
Method Statement No.:	MS-CCS-001	Revision No.:	01
Anticipated Start Date:	TBC	Anticipated Duration:	3-4wks.
Site Working Hours:	Mon – Fri: 08:00–17:00hrs	Saturday: 08:00–13:00hrs by Approval Only	Sunday: None

Location of Works:

Land East of Copart, Prince William Avenue, Queensferry, Sandycroft, Flintshire, CH5 2QZ
 Grid Reference- SJ 34437 67286 / 334437 (E), 367286 (N)

HEALTH AND SAFETY

METHOD STATEMENT

Overview of Scope:

Trenchless Drainage Outfall Construction Beneath Existing Flood Bund Utilising Guided Auger Boring consisting of:

- Prestart Inspection & Mobilisation
- Establishment of Working Areas
- Auger Boring Launch Shaft Construction (Entry Side) & Auger Boring Termination Temporary Excavation (Exit Side)
- Auger Boring Machine Setup- Machine Placement, Line and Level Establishment, Prestart Checks & Pilot Rod Installation
- Auger Boring Drilling & Pipe Installation
- Precast Concrete Headwall Construction
- Demobilisation

Description of Works & Safe Working Arrangements:

General Pre- Start Requirements

- All site personnel will receive full MYCO Site Induction prior to starting works on site.
- Trade Specific training records must be produced by the relevant trades prior to starting works on site.
- All operatives will attend Daily Activity Briefings & RAMS Briefings for the specific works carried out by the MYCO Supervisor. Confirmation of understanding these briefings will be recorded by signing onto a Project Briefing Record. – Where required, Translators will be used.
- Housekeeping standards are to be monitored and maintained at all times.
- All operations carried out in strict accordance with all applicable Health and Safety legislation, CDM regulations, MYCO Safety Policy and all site-specific rules and policies.
- Emergency contact details in the event of accident/injury to an operative RA on operatives known to have a medical condition.
- Full 5-point protective PPE is to be made available and worn by operatives.
- All site personnel to follow designated site walkways and logistics plan for safe access and egress to and from the work areas.
- Welfare facilities will be available in the MYCO compound consisting of a self-contained mobile oasis unit. These welfare facilities are to be treated and used with respect.
- Considerations will need to allow for safe access and egress for pedestrians, accessibility for plant movement such as excavator dumper, roller etc. MYCO supervisors to arrange layout as per the site-specific conditions, vehicle movements will be managed at all times by a trained vehicles banksman (Traffic Marshall).
- Vehicle access and deliveries will be via designated logistic access/ egress gate.
- Avoid manual handling whenever possible by using mechanical means. Persons carrying out manual handling operations will be trained, physically fit and willing to undertake the task. Maximum manual lift to be 20 kg per person according to the HSE Guidance.
- An excavation shall be inspected daily by competent person from MYCO and before any person enters into the excavations. Edge protection will be in place to prevent slips, trips, and falls.
- All works areas are to be protected using either pedestrian or heras fence panels, all panels to be clipped together and suitable weighted down, Supervisor by others to advise on type of fencing and weights for each individual area.
- Material deliveries pre-arranged with MYCO and off loaded by the HIAB or Excavator. Trained and certified lifting team briefed and signed onto approved Lift Plans for all Lift operations.

HEALTH AND SAFETY

METHOD STATEMENT

Description of Works & Safe Working Arrangements:

- All works will be carried out in compliance with the Working at Heights Regulations 2005 and will refer as necessary to the WDC Guidelines.
- Dilapidation photographs are to be taken of the prestart site condition etc. These should be taken at regular intervals during the construction period and final works completion.

Establishment of Working Areas

- Prior to commencement of works a site walkover survey will be conducted to ensure the safe system of work compiled can be delivered.
- A Point of Work Risk Assessment will be conducted the MYCO Site Supervisor and appropriate supervisor before works commence.
- Due the sensitivity of working adjacent to a live water course and public right of way footpath an Environmental and Ecological review will be included within the site walkover to identify the environmental wildlife which could be affected by the proposed works, if necessary, actions will be taken to minimize the effects relevant management parties informed of any significant findings.
- Works Area Segregation Installation- Construction Plant Access/ Egress. Pedestrian Footway Segregation
- Emergency rescue provision will be put in place via outside of the segregated works area consisting of Lifebuoy and encapsulated throwing line.
- If any operative requires to be outside of the segregated works area or will setting up the segregated works area they must be wearing a Life Vest, Safety Harness and attached to a fall arrest retriever devise which is attached to a fixed anchor point.
- To facilitate safe access/ egress and prevent any surface damage to the flood earth bung surface protection ground matts will be installed where pedestrian or plant movement maybe required.
- Secured heras fencing will be installed to segregate the required areas and from a physical barrier between works area and River Dee water shoreline. Safet Signage shall be suitably installed.
- Dewatering pumps will be available if the need arises to dewater any groundwater entering into works excavations. A sump pump must be supplied and discharged into a skip or other receptacle to first permit silts to settle before the pumped water is allowed into the below ground drainage system.
- MYCO engineer to mark out the extent of the works area and proposed construction works.
- MYCO Engineer to conduct a full CAT & Genny survey of the proposed works site, clearly marking with the works proposed works area and recording all findings within the permit to break ground any findings. In addition, all available statutory services drawings which have been provided will be reviewed in line with the proposed works.
- If live services or unknown services are indicated, then trial holes are to be conducted employing safe digging practices to expose the services before any mechanical excavation means can proceed.
- MYCO to issue/ obtain all required permits to break ground and all relevant information of services will be contained with the permit. The permit is to be briefed to all operatives involved in breaking ground operation works.

Auger Boring Launch Shaft Construction (Entry Side)

- Prior to any drilling work commencing, the working site will be established. Work will be undertaken from a 2.1m diameter shaft. Details of the requirements for pits and shafts can be found in the below. All shafts and excavations shall have suitable edge protection, access/egress and davit arm system for emergency access and egress.
- The launch shaft will located with Copart Chester Land Parcel.
- Excavation will consist of an open cut methodology with trench support being formed from excavation battering or sloped earthworks cutting. It is not envisaged that any temporary works or temporary works design will be required to be deliver the shaft construction or guided auger boring works. However, if site

HEALTH AND SAFETY

METHOD STATEMENT

Description of Works & Safe Working Arrangements:

circumstances change or we are unable to deliver and open cut method a temporary works shoring system and associated temporary works design will be sort.

- Chambers will be constructed as per the Shaft Chamber Design.
- Fence off area of work before excavation commences
- Engineer to set out the excavation area /level



- Issue permit to break ground (Hold point)
- Excavate trench to proposed level use of Excavator
- The sides of the excavation will be stepped and battered
- Excavation level will be controlled by laser level
- Excavated material will be taken away from the works area to stockpile area via use of dumper

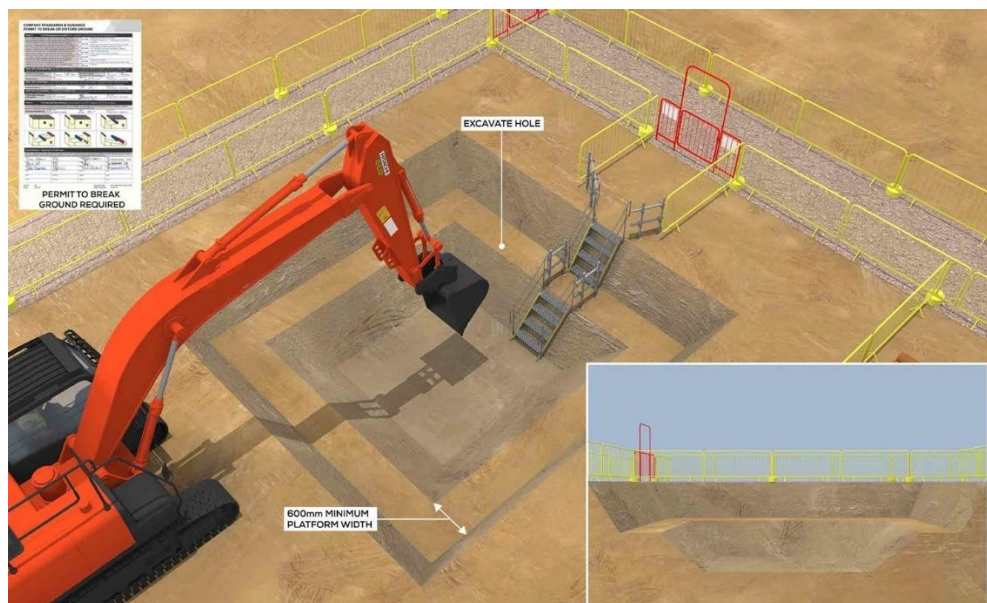

- Place concrete into the excavation using the excavator and level off by handheld shovel. When placing concrete operatives to exit trench until its placed, DO NOT stand under lifting Load and DO NOT lift over operatives

HEALTH AND SAFETY

METHOD STATEMENT

Description of Works & Safe Working Arrangements:

- Install rocker pipes & construct the base for manhole
- A pipe sleeve will be cast into the upstream 600mm thrust block to allow for future inlet drainage connection.
- To allow for guided Auger Boring an 500mm sq. outlet must be cut out the precast manhole ring and concrete sound for the downstream boring operations. concrete base is to be set at approximately 850mm below centre line of new pipe.
- Once base concrete has gone off in manhole set first ring into position
- After completion of manhole base construction, the required first manhole ring will be installed ensuring sufficient embedment is achieved into the manhole base.

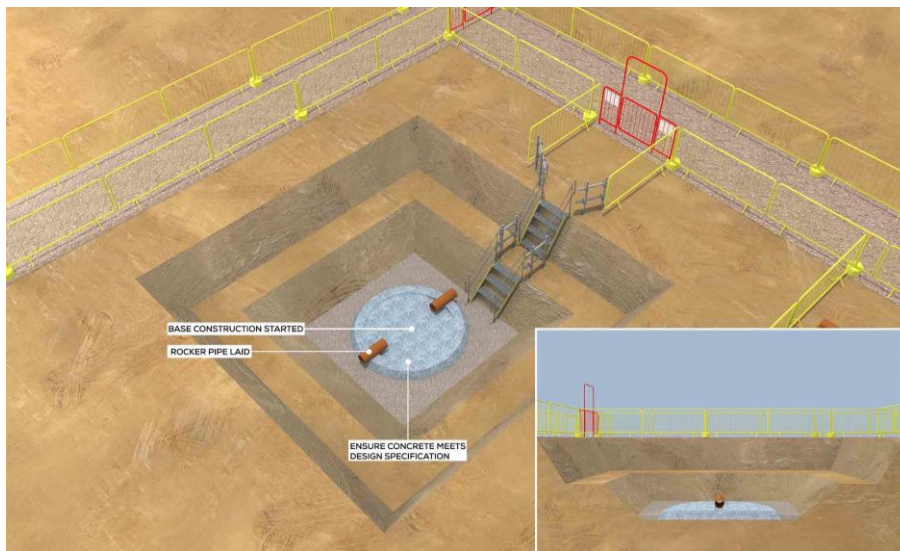

- Attach ring to chains with lifting eyes, or if suitable with use of spider MH ring lifter. Chains to be secured to machine with D shackle as per approved lifting plan.

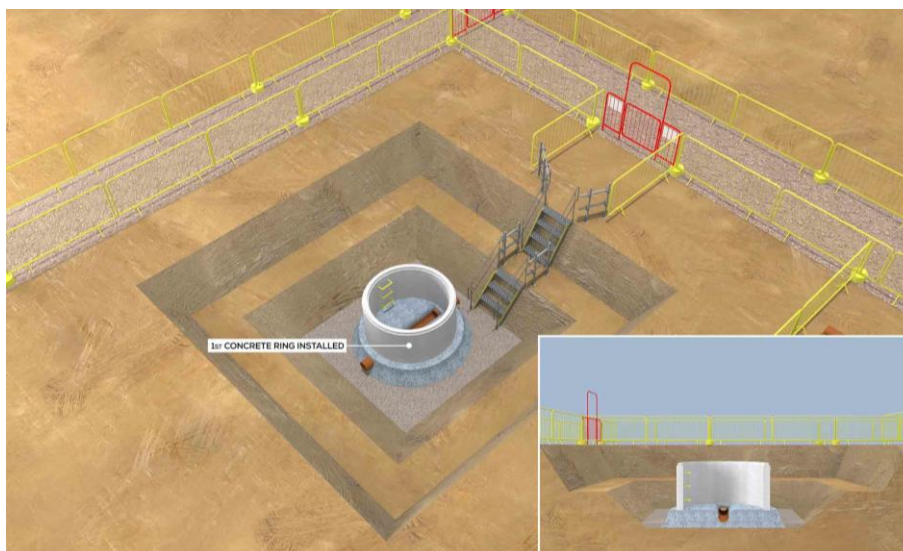

- Bench all manholes before second ring or cover slab is installed to avoid works having to be completed under confined space working procedure. If not achievable then the confined space working procedure must be followed. (Confined space trained personnel required, Set up Tripod + Gas Monitor with safety Harness to enter, Confined space works task sheet will be issued/briefed before start works to operatives and Confined space entry permit will be issued by MYCO management (Hold Point).

HEALTH AND SAFETY

METHOD STATEMENT

Description of Works & Safe Working Arrangements:

- Build-up MH to construction finish level, place on biscuit and cover access hole.

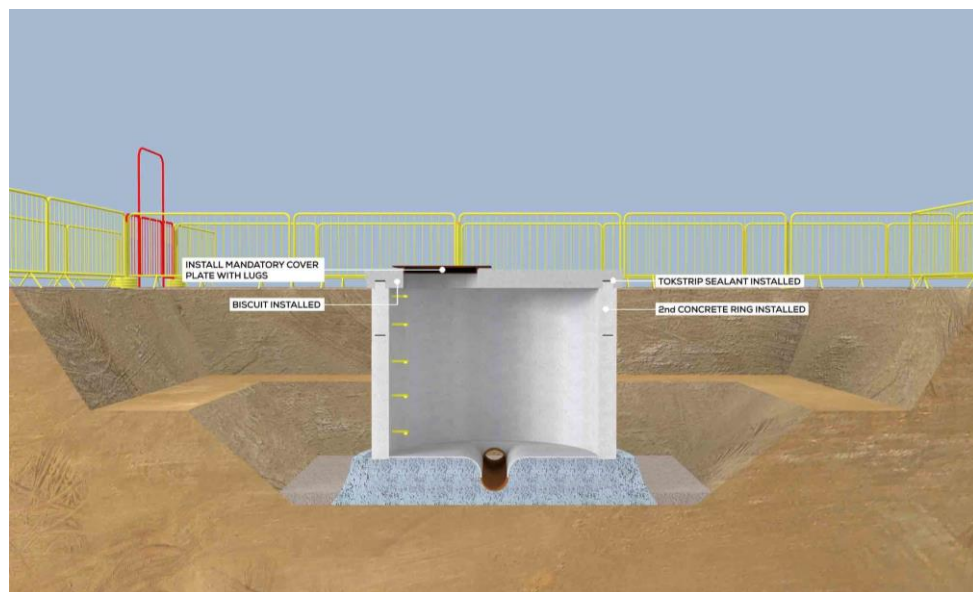
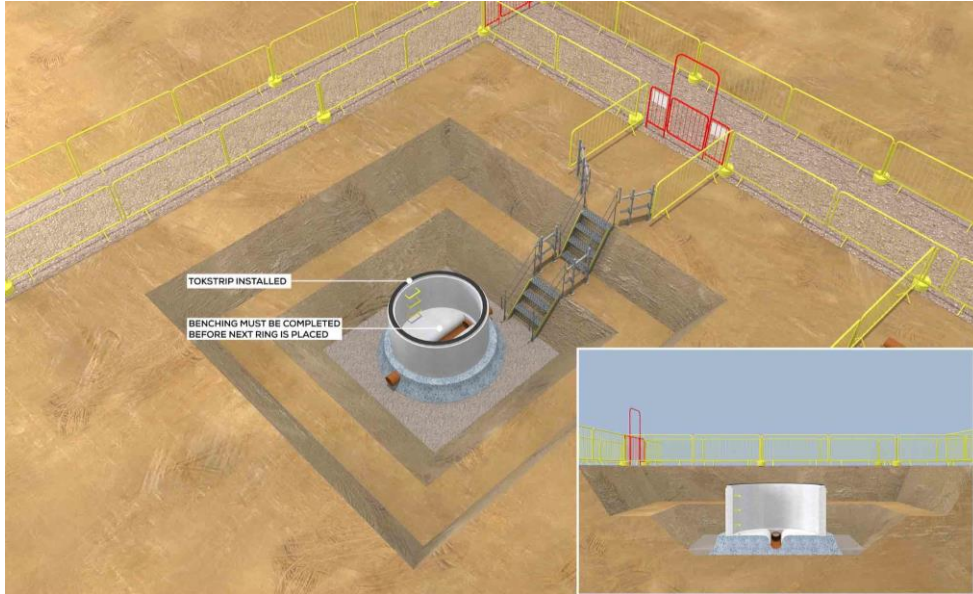

- Once manhole rings are installed place manhole shutter surround.
- Place concrete between manhole shutter & manhole ring as per details & spec.
- Concrete to be vibrated using vibrating poker.

HEALTH AND SAFETY

METHOD STATEMENT

Description of Works & Safe Working Arrangements:

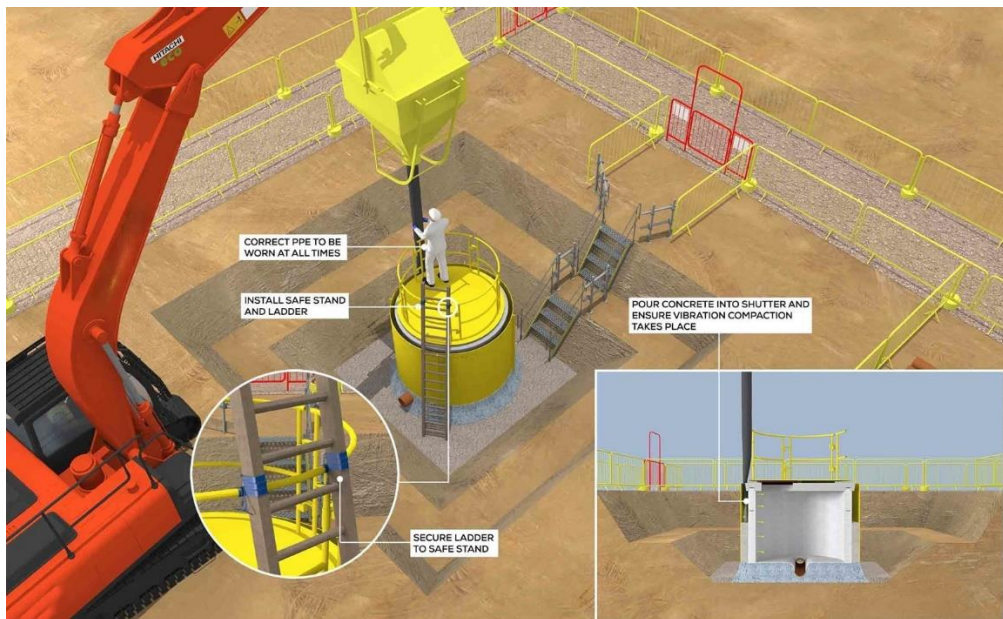
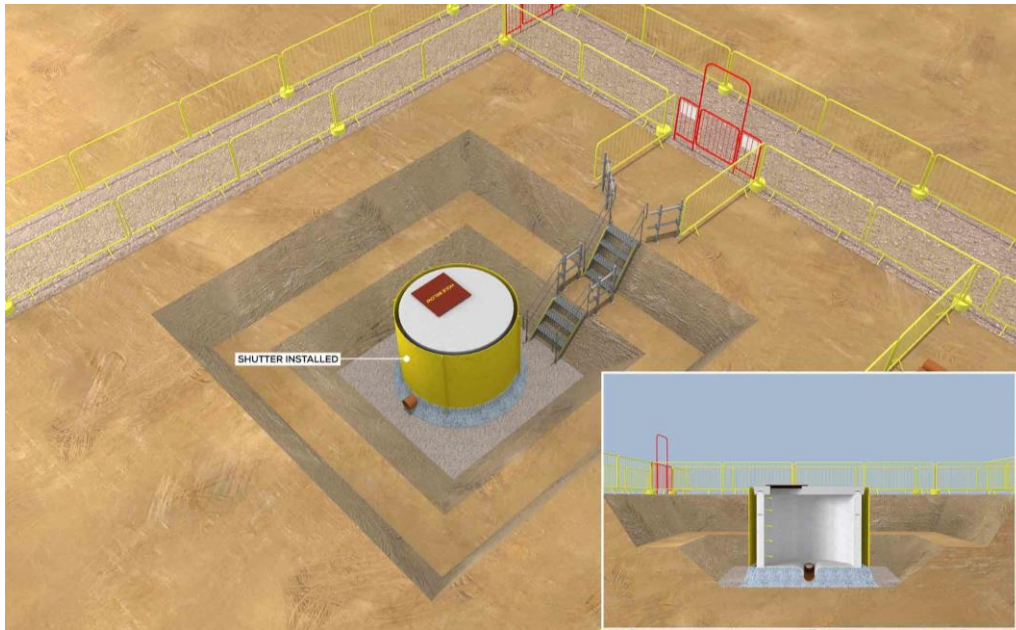

- Remove shutter once concrete has gone off
- Backfill with approval material in specified layers
- Place heavy duty steel plate over access hole until cover and frame are installed. No holes or chambers are to be covered with timber

HEALTH AND SAFETY METHOD STATEMENT

Description of Works & Safe Working Arrangements:

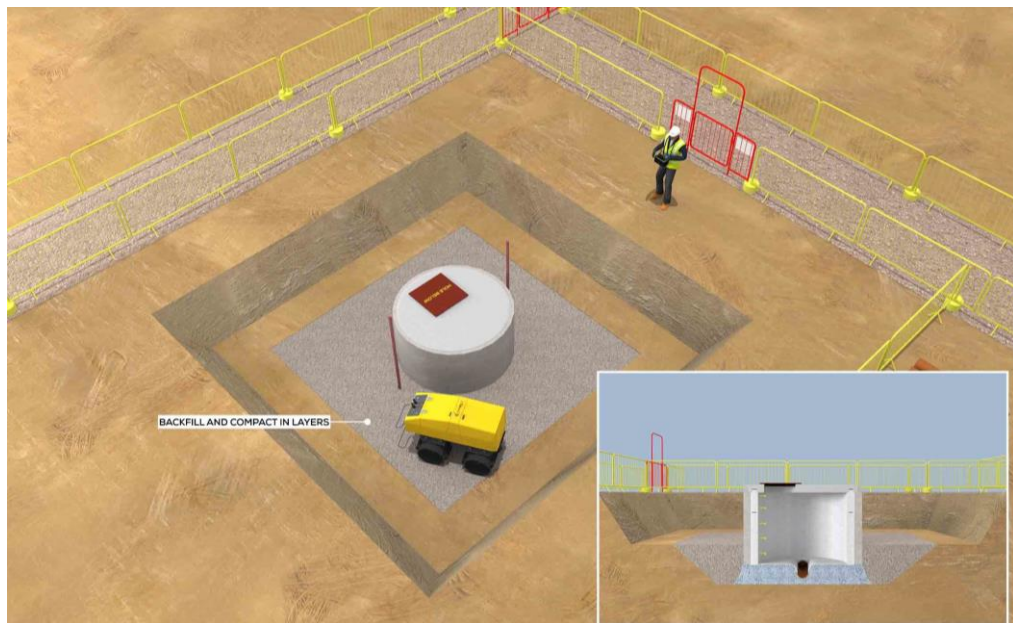
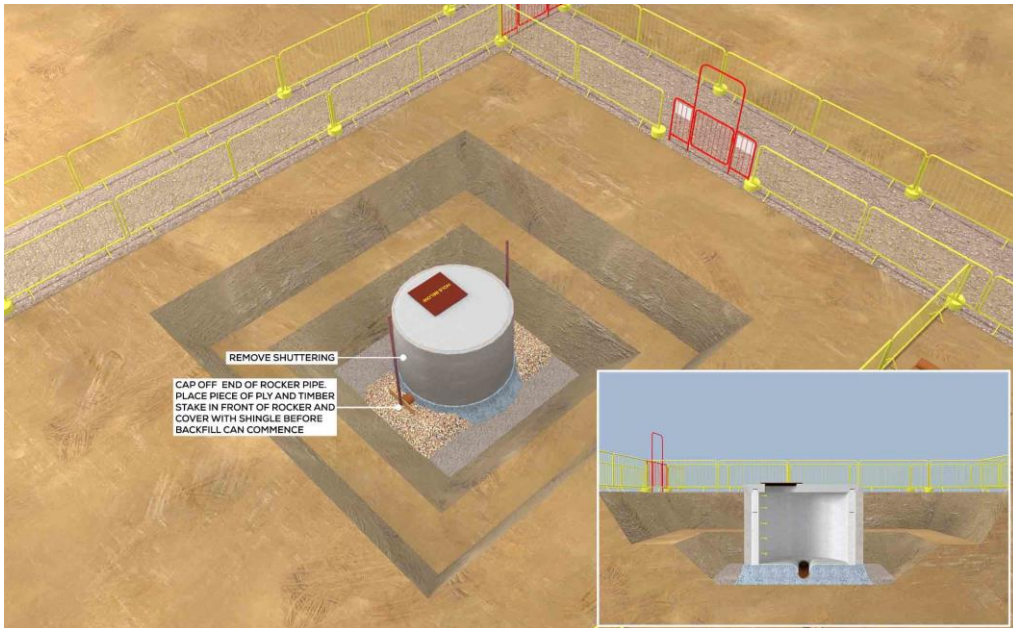

HEALTH AND SAFETY

METHOD STATEMENT

Description of Works & Safe Working Arrangements:

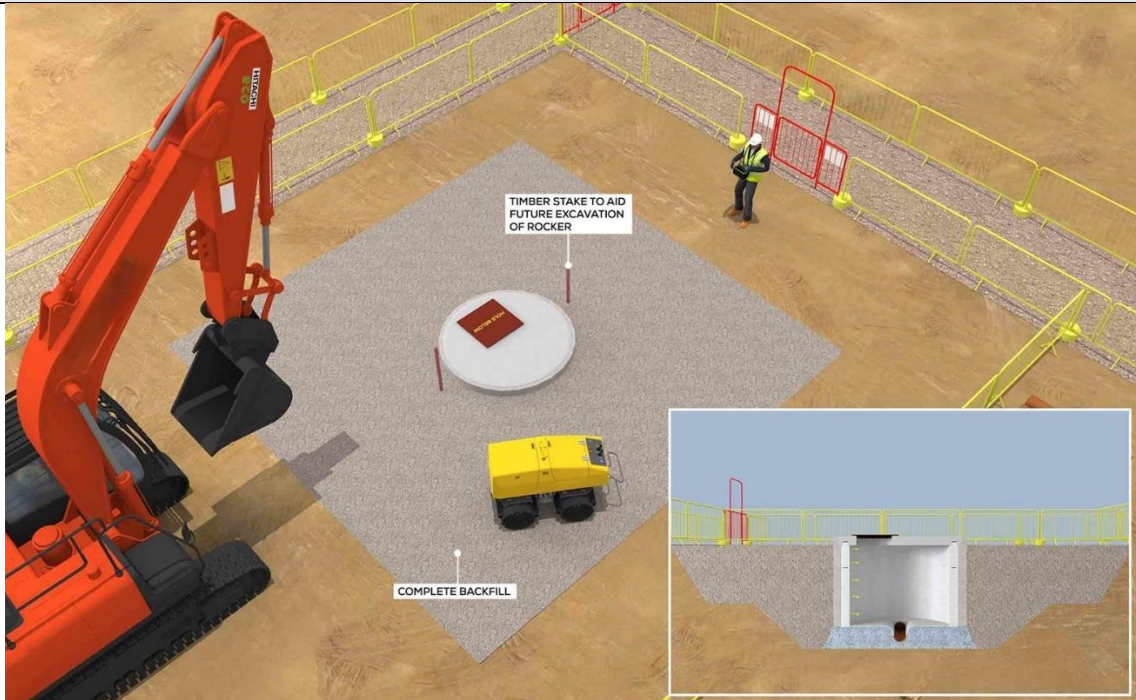

- Post manhole backfill the cover slab shall be removed and fixed edge protection with gated secured ladder access to within the shaft installed and safety rescue davit arm system.

Auger Boring Termination Temporary Excavation (Exit Side)

- The termination pit is located in the land space adjacent to River Dee watercourse under restricted work permit control of Natural Resources.
- The bore is due to terminate within exit shaft similar sized temporary excavation to the launch pit. However, this pit will be formed and remain an open excavation. The pipe exit level is formed with the earthwork flood bund and therefore will be exiting at a shallow depth within close proximity to the River Dee shore edge.
- To protect workers the tidal pattern will be checked and observed for the full duration of the works. A temporary sandbag wall will be constructed between the shore edge and the proposed drainage headwall.
- If any operative requires to be outside of the segregated works area or will setting up the segregated works area they must be wearing a Life Vest, Safet Harness and attached to a fall arrest retriever devise which is attached to a fixed anchor point.

Auger Boring Machine Setup- Machine Placement, Line and Level Establishment, Prestart Checks & Pilot Rod Installation & Auger Boring Drilling & Pipe Installation

- The methodology chosen for the trenchless drainage outfall construction beneath existing flood bund is Guided Auger Boring. This methodology is very precise, requires minimal working space, will maintain the integrity of the earthworks flood bung and will require minimal invasive works.
- All lifting operations will be conducted via the use of a suitably sized excavator and in accordance with project specific lifting plan.

HEALTH AND SAFETY

METHOD STATEMENT

Description of Works & Safe Working Arrangements:

- The auger boring rig is set up on a prepared concrete base, 150mm thick, laid level. The length of the steel casings and Naylor to be installed are one meter in length.

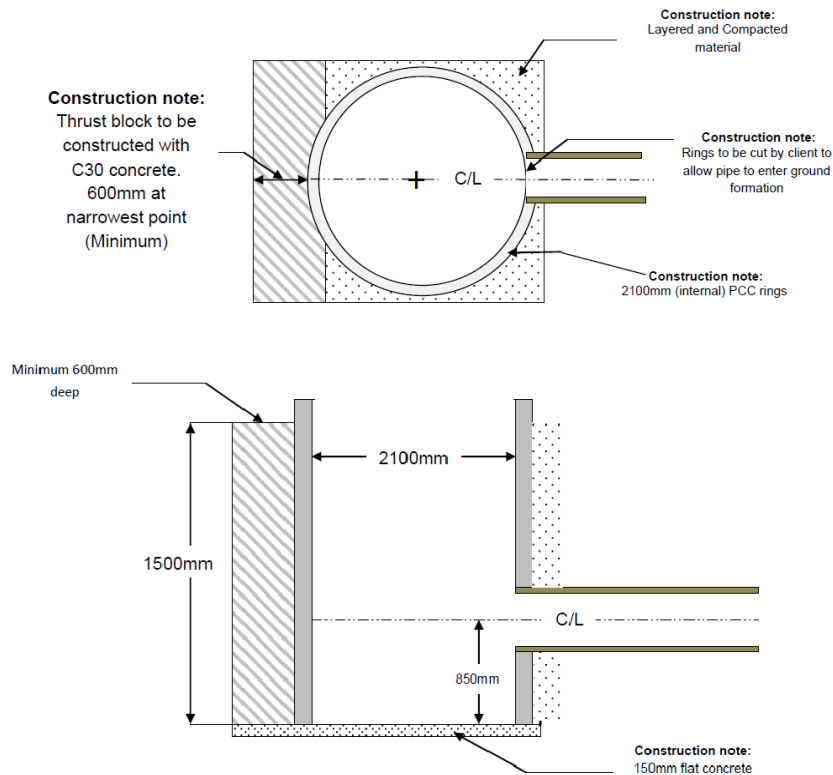

- The top of the 150mm concrete base is to be set at approximately 850mm below center line of new pipe. The machine should be supported at the rear of the pit by a concrete thrust block, with a minimum thickness of 600mm, and a minimum depth of 1.5 meters above the base level.
- The auger boring rig to be utilised for the installation will be a Bohrtec BM400. The machine sub-frame is 2 meters long with adjustable front and rear plates. The unit, including the gearbox, has a total weight of 2500Kg. Lifting attendances will need to be procured accordingly. The machine is powered by a hydraulic power pack which in turn is powered by a diesel engine. Below is an indicative site setup that will be established at the launch chamber.
- All operatives working in the shaft must have received the confined space and harness training and wear a fully body harness connected into the davit arm at all times whilst inside the excavation. In the event of an operative becoming ill the top man will raise the alarm (a Claxton horn) operatives will then come to help and call the emergency services if required. The winch will then be raised which will be raise the operative to safety and first aid. Training & equipment certificates must be issues to MYCO prior to commencing works.
- Emergency Resue- Operatives entering the excavation are to wear rescue harnesses and personal gas detectors and exit immediately if the alarm sounds. The supervisor is to be informed, and all works are to stop.
- No lone working is permitted , a top man is always to in place, if operatives are in the shaft.

HEALTH AND SAFETY

METHOD STATEMENT

Description of Works & Safe Working Arrangements:



- The sub-frame is set up for line and level before the machine is lowered onto it. Line and grade shall always be set at the point of launching.
- The machine sub-frame is set up to incorporate three factors which are to be obtained prior to machine set-up:
 - Axis. The machine axis (centre of pipe) is set at 850mm from the base of the launch shaft. Pipe axis is to be marked on the shaft wall.
 - Line. A line of drive for each shot is to be marked at the top of the shaft at both the front and the back. The thrust block must be perpendicular to the line of drive.
 - Gradient. The sub-frame is set at the same gradient required for the pipe that is to be installed. This gradient should be given as a percentage. Once the pilot commences the gradient is continually monitored using the optical guidance system.



HEALTH AND SAFETY METHOD STATEMENT

Description of Works & Safe Working Arrangements:



- The pilot rods are pushed through the virgin ground using the auger bore rig. These are guided to line and level using the optical guidance system. Once the reception shaft has been reached the pilot procedure is complete.



HEALTH AND SAFETY

METHOD STATEMENT

Description of Works & Safe Working Arrangements:



- The first casing and auger are positioned; the auger is attached to the pilot rods via a swivel assembly. The auger and casing are pushed forward simultaneously behind the pilot rods. This ensures that as the steel is installed it follows the optically guided pilot meaning that deviation cannot occur and line and level accuracy is maintained.



- Once the first auger has been inserted, the auger drive is retracted, a new auger & casing placed and auguring continued. As these augers and casings are pushed forward the pilot rods are pushed into the reception shaft and disconnected.

HEALTH AND SAFETY

METHOD STATEMENT

Description of Works & Safe Working Arrangements:

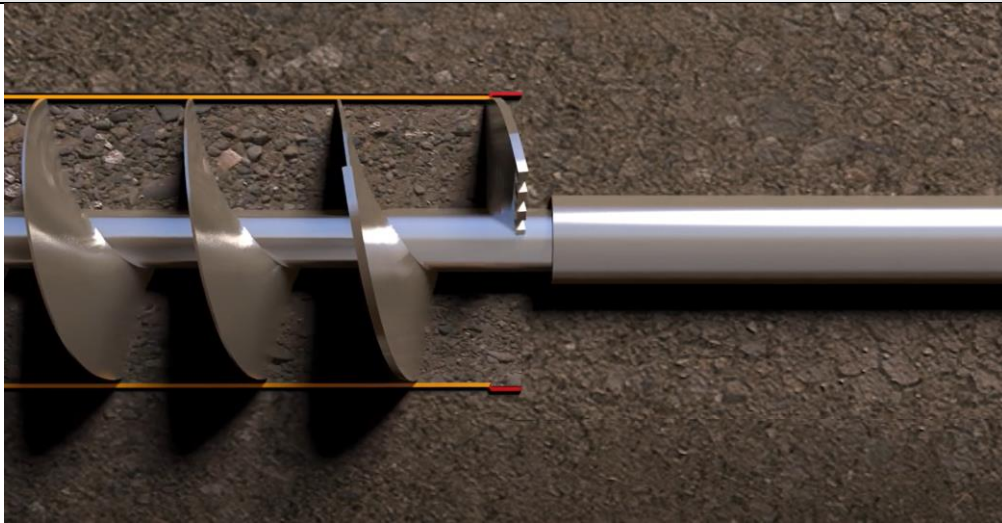

- The spoil is brought back to the launch pit by the rotating augers and deposited into a skip or a ton bag situated in the bed of the machine. The skips/bags are periodically lifted/craned from the shaft and emptied. Waste will either be locally stockpile within Copart land space and sealed or suitably disposed off site.



HEALTH AND SAFETY METHOD STATEMENT

Description of Works & Safe Working Arrangements:



- The process is repeated until the augers reach the reception shaft. At this time, the augers are retracted, disconnected and then removed from the launch pit. The steel sleeving is left in place.



- A pipe push adapter is then fitted to the steel and the jacking pipe is pushed through the ground whilst the steel is simultaneously removed in the reception shaft. Once the jacking pipe reaches the reception shaft the pipe installation is completed, and equipment will be removed.

HEALTH AND SAFETY METHOD STATEMENT

Description of Works & Safe Working Arrangements:



**HEALTH AND SAFETY
METHOD STATEMENT**

Description of Works & Safe Working Arrangements:

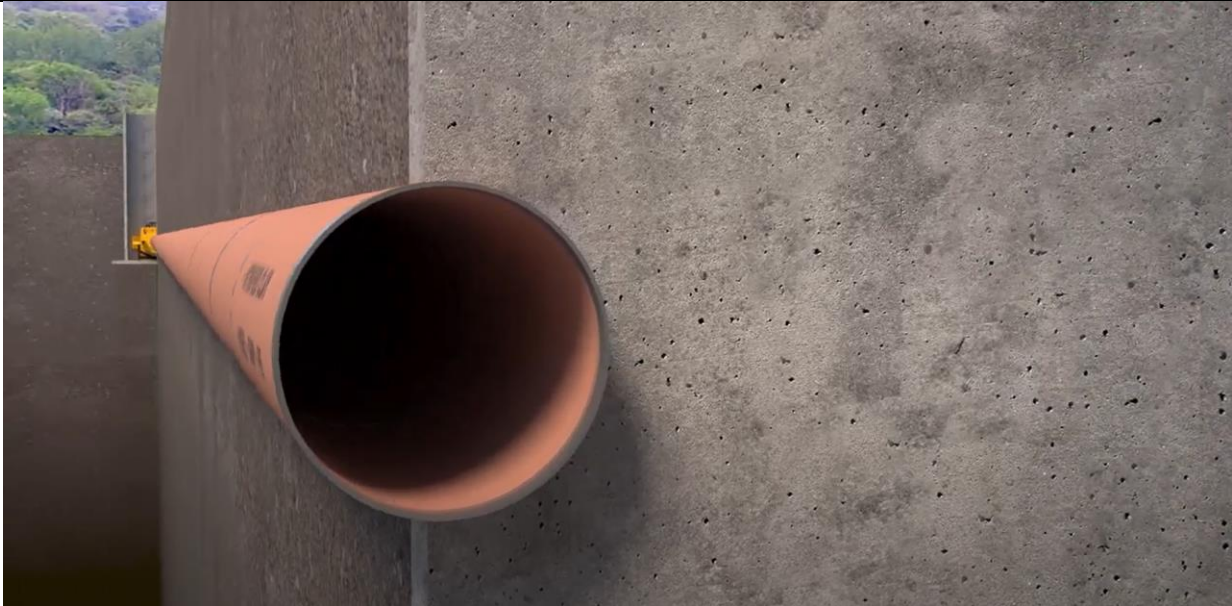

Precast Concrete Headwall Construction

- A precast head will be installed to the outfall pipe adjacent to the River Dee.
- Cut and install the last section of pipe that the headwall will cover. Ensure that the pipe is fully fitted leaving either the first (or last) section of pipe free from backfill to attach to the headwall.
- Temporary sandbag protection wall will need to be removed to facilitate headwall install on to installed pipeline and to install scour protection requirements. As such operatives will be required to be wearing a Life Vest, Safet Harness and attached to a fall arrest retriever devise which is attached to a fixed anchor point.

HEALTH AND SAFETY

METHOD STATEMENT

Description of Works & Safe Working Arrangements:

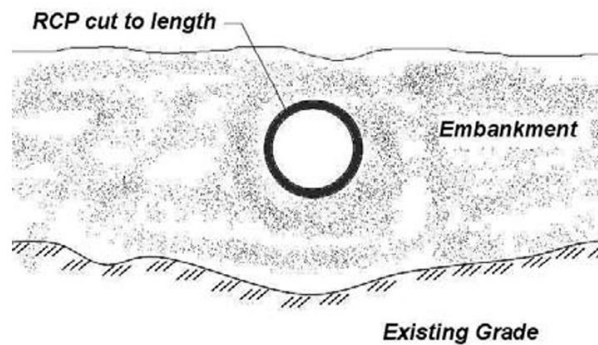

- Before laying bedding, ensure the final position of the headwall is excavated to the required formation level with sufficient excavation to house the toe (particularly when toe extensions are used) along the front of the excavation. Line the excavation with geotextile then a minimum of 200-300mm well graded granular material, compacted particularly around the back of the toe, then a 50mm blinding layer of sharp sand.
- In adverse ground conditions it may be necessary to use a minimum of 75mm thick concrete bed with a 50mm thick granular overlay (headwalls should not be laid on bare concrete). Ultimately, the bedding should ensure that any irregularities are levelled out to create a uniform support for the headwall to be laid on, without effecting the jointing to pipework. If surrounding soil is likely to be relocated into the backfill, then the bedding should be wrapped in a geosynthetic material.

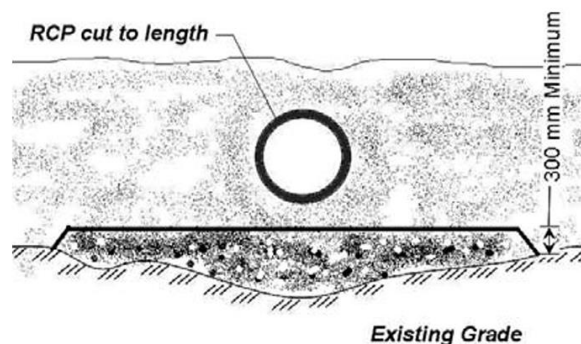

- Check that the correct headwall has been delivered by cross referencing the compatibility of the pipe connection diameter and the hole in the headwall. Straight cored holes should measure wider than the diameter of the connecting pipe to allow for placement and grouting. Likewise, the outer rebate of a formed and stepped hole should also measure wider than the diameter of the connecting pipe, while the inner hole should be the same diameter as the inner diameter of the pipe.

HEALTH AND SAFETY

METHOD STATEMENT

Description of Works & Safe Working Arrangements:



- When satisfied, use suitably rated three/four leg hook and chain (or sling) set to lower the headwall onto the prepared bed, carefully aligning the headwall over the end of the pipeline (where applicable).

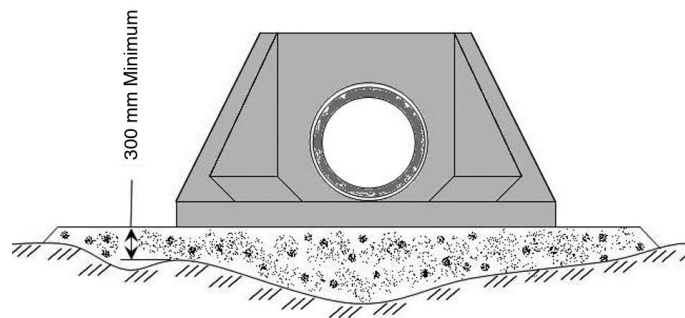

- Depending on the type of connection to be made to the headwall, the pipe should either be flush with the front face of the back wall for a straight through hole connection or flush with the inner rebate of the stepped connection so the internal diameter of the pipe and the front facing hole are concentric. Both styles require the filling of the void created between the circumference of the pipe and hole, with sand cement mortar or a high strength non-shrink grout or similar.

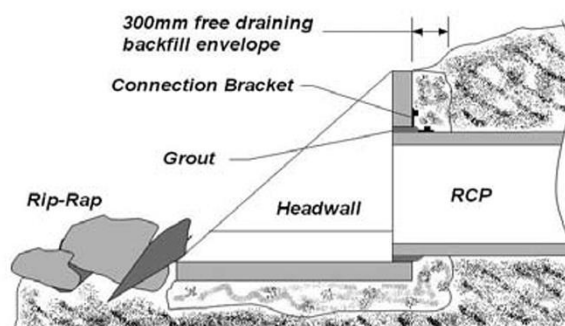

HEALTH AND SAFETY

METHOD STATEMENT

Description of Works & Safe Working Arrangements:	
<ul style="list-style-type: none"> • Backfilling should commence as soon as possible after the headwall has been laid. Selected backfill material (typically similar to surrounding soil, free from large lumps, roots, rubbish or building rubble). The pipe section should be backfilled first, then around the headwall while compacting well at the front of the toe. Compacting should be in layers of maximum 200mm, working evenly on each side of the headwall. It may be necessary to provide protection in front of the toe, please refer to engineers' recommendation. • Metal Grating will be installed post backfill to prevent any potential pipe entry. • Erosion & Scour protection will be installed to help prevent embankment soil from washing away and maintain the integrity of the drainage system. 	
	
<p><u>Demobilisation</u></p> <ul style="list-style-type: none"> • On Completion works area will be cleared of all materials and construction equipment. • A joint inspection will be conducted with all relevant parties. 	

PART TWO:				
Supervision & Works Management:				
Name of MYCO Supervisors:	CSCS	CPCS	SMSTS	SSSTS
1. TBC				
2. TBC				
Sub-contractor Management:				
Sub-contractors Used:	Yes	Sub-contractors MS & RA's [Approved]		TBC
1. Specialist Groundworks Contractor		Enabling Works, Shaft Construction, Head Wall Construction		

HEALTH AND SAFETY

METHOD STATEMENT

2. Specialist Auger Boring Contractor	Specialist Guided Auger Boring and Pipe Installation.
---------------------------------------	-------------------------------------------------------

Significant Risk & Hazard Identification:			
Who Might be Harmed?:			
Site Operatives	Yes	3 rd Parties & Public	Yes
Other Contractors	Yes	Environment	Yes
Hazard Identification: [delete as applicable]			
Slips, Trips & Falls	Yes	Access & Egress	Yes
Manual Handling [see Appendix for Assessment]	Yes	Lighting – general & task	Yes
Plant & Machinery	Yes	Hand Tools	Yes
Excavations	Yes	Vibration	Yes
Confined Space	Yes	Noise	Yes
Traffic Management	Yes	COSHH	Yes
Lifting Operations	Yes	Dusts & Fumes	Yes
Fire & Hot Works	Yes	Asbestos	No
Work at Height	Yes	Fall of Materials	Yes
Other- Burning/ Cutting/ Welding	No	Other: Adjacent Water Course (River Dee)	

Required Operative Competencies: [delete as applicable]			
CSCS [General]	Yes	JIB / ECS [electrical]	No
CPCS [Plant]	Yes	FASET [nets / rope access]	No
CISRS [Scaffolding]	No	Abrasive Wheels [Stihl saws]	Yes
CCDO [Demolition]	No	First Aid [at Work / Appointed Person]	Yes
Asbestos Awareness [Demolition]	No	Fire Awareness / Marshalls [Hot Works]	Yes
PASMA [Mobile Towers]	No	IPAF [MEWPS & SPB's]	No
Other- Temporary Works- Excavations	Yes		

Personal Protective Equipment Requirements: [delete as applicable]										
Yes	Yes	Yes	Yes	Yes	Yes	Yes	Yes	Yes	Yes	Yes
PPE Minimum Specification:										

HEALTH AND SAFETY

METHOD STATEMENT

Personal Protective Equipment Requirements: [delete as applicable]	
Hi-Vis Clothing [high speed roads, railways, DLR]	Class 2 Yellow Hi-Vis Vest
Protective Footwear [toecap, midsole, slip, chemical]	Safety Boots, including ankle support, toecap & midsole
Gloves [abrasion–cut–tear–puncture / chemical]	General- Mechanical hazard rating [4-1-3-1] to EN 388 Hot work's- Flame & Cut Resistant to EN 659 and NFPA 1971-2013
Eye Protection [glasses / goggles – impact, dust, liquids, welding]	Medium Energy Impact Goggles with dust protection
Respiratory Protective Equipment [dust / fume]	FFP3 Dust & Mist disposable half masks
Hearing Protection [Ear Plugs / Ear Muffs]	Ear Muffs / Plugs with SNR Rating minimum of SNR25 Ear Defenders with SNR Rating Minimum SNR27
Protective Overalls [Contaminated Land / COSHH (Concrete Works)]	Chemical splash, tear and abrasion resistance- Category III, Type 5-B and 6-B.
Other: Protective Overalls [Cutting, Burning Welding]	Flame Retardant & Anti-Static- EN ISO 11612 A1+A2 B1 C1 E3 F1- EN ISO 11611 Class 1 A1+A2- EN ISO 20471 Class 3 - EN 1149 -5

Personal Fall Protective Equipment Requirements:	
Are 'Work at Height' operations required during the completion of the works?	Yes
Has the 'Work at Height Regulations' hierarchy for management and selection of work equipment been applied?	Yes
Full Description of 'Work at Height' Operations required and work methodology:	
Operation 1.	Excavation for Auger Boring Launch Shaft Construction (Entry Side)
Operation 2.	Excavation for Auger Boring Termination Temporary Excavation (Exit Side)
Operation 3.	Constructed Access Shafts Access & Egress
Operation 4.	Operative Access & Egress Transiting Existing Flood Bund Embankment
Fall Protection Equipment Required:	
Yes	
Operation 1.	Excavation & Works Exclusion Fencing
Operation 2.	Excavation, Works Exclusion Fencing & Temporary Sandbag Protection Wall
Operation 3.	Confined Space Access Equipment- Davit Arm System, Secured Ladder Access, or Excavation Access Staircase
Operation4.	Anti Slip Ground Protection Matts, or Excavation Access Staircase
Designated anchor points to be used for the works:	
Yes	
Operation 1.	Fixed anchor points full body harness & restriction lanyard for Entry Shaft Construction
Has a work at height rescue plan been developed?	
No	

HEALTH AND SAFETY

METHOD STATEMENT

Statutory Inspections, Site Monitoring & Certification Requirements: [delete as applicable]			
Working Platforms / Scaffolding	Yes	Mobile Tower, Ladders & Podium Steps	Yes
Excavations	Yes	Cofferdams & Caissons	No
Confined Space Escape Sets Certification	Yes	Vibration Exposure	Yes
Gas Monitor Calibration	Yes	Manual Handling	Yes
Noise Assessments	Yes	MEWP or SPB 6 monthly certification	No
COSHH Assessments	Yes	Lifting Plant 6 or 12 monthly certification	Yes
PUWER & Weekly Plant Checks	Yes	Lifting Equipment 6 monthly certification	Yes
PAT Testing Certification	Yes	Fall Restraint or Arrest Harnesses	Yes
CAT & Genny Certification	Yes	EDM, Survey & Laser Level Calibration	Yes

Permits, Hold & / or Control Points: [delete as applicable]			
Permit to Work [High Risk Activity]	No	Permit to Break/ Disturb Ground	Yes
Hot Works Permit	Yes	Confined Spaces Permit	Yes
Permit to Work on or Near Live Electrics	No	Mobile, HIAB & Crawler Lifting Permit	Yes
Permit to Access, Load or Strike	Yes	Permit to Pump Concrete	No
Permit to Demolish	No	Quality Control or Inspection Test Plan	Yes
Environmental or Ecological Watching Brief	No	Clerk of Works or Building Control Inspection	No
Other [state]	No		

Plant, Deliveries & Work Equipment			
Operated Plant: [delete as applicable]			
Excavator [all sizes]	Yes	Articulated Dump Truck [all sizes]	No
Dumper [all sizes]	Yes	Compaction Rollers [all sizes]	No
MEWP's [all sizes]	No	Mobile or Crawler Crane [all sizes]	No
MEWP's / Scissor Lifts [all sizes]	No	Self Propelled Booms / Cherry Pickers	No
Lorry Mounted Concrete Pump [all sizes]	No	HIAB or Grab Lorries	Yes
Other [state]	No		
Anticipated Delivery & Waste Removal Vehicles: [delete as applicable]			
Concrete Agitator Delivery Vehicles	Yes	HGV Articulated Delivery Lorries	Yes
8 Wheeled Lorries	Yes	Waste Skip Removal Lorries	Yes
Other [state]	-		
Small Plant & Work Equipment: [delete as applicable]			
Compressors & Generators	Yes	Breakers & / or Demolition Picks	Yes

HEALTH AND SAFETY

METHOD STATEMENT

Plant, Deliveries & Work Equipment			
Compaction & Wacker Plates	Yes	Heavy Duty, Hammer & / or Rotary Drills	Yes
'Stihl' Saws, Grinders & / or Abrasive Wheels	Yes	Skill, Rip, Circular & / or Jig Saws	Yes
Mobile Scaffolds, Podiums & Ladders	Yes	General Site Lighting [e.g. Tower Lights]	Yes
Cable Locating Devices / CAT & Genny	Yes	Task Specific Lighting	Yes
Manhole & Trench Boxes & / or Sheets	No	Lifting Equipment, Slings & Chains	Yes
Other [state]			

Lifting Plans & Operations: [delete as applicable]			
Lifting Plans Required:	Yes	Appointed Person:	TBC
Lifting Plan Title:		Document Number:	Lifting Plan Risk Category:
1. Excavator- Used as crane TBC		TBC	Standard

Temporary Works:			
Temporary Works Required:	No	TW Co-ordinator:	TBC
Temporary Works Title:	Document Number:	TW Risk Level:	3 rd Party Check by:
-	-	-	-

Materials & COSHH			
Materials to be Used:			
<ul style="list-style-type: none"> In situ Concrete, Precast Concrete Manhole Segments, Steel Reinforcement, Timber Shuttering, Steel Pipe, Clay Pipe, Precast Concrete Headwall 			
COSHH Materials to be Used:			
<ul style="list-style-type: none"> Concrete Diesel 			
COSHH & Materials Storage Arrangements: [delete as applicable]			
Location [state]	MYCO Established Contractor Compound within Copart Land Space	Lockable	Yes
Emergency Spill Kit Available [Chemical]	Yes	Bunded	Yes

Refuelling Arrangements: [delete as applicable]			
Designated Static Refuelling Area	No	Location [state]	MYCO Contractor Compound
Emergency Spill Kit Available	Yes	Double Bunded & Lockable Unit	Yes

HEALTH AND SAFETY

METHOD STATEMENT

Refuelling Arrangements: [delete as applicable]			
Mobile Bunded Refuelling Bowser	Yes	Designed Fuel or Gerry Cans	Yes
Plant Nappies & / or Drip Trays	Yes	Emergency Spill Kit Available [Oil]	Yes

Environmental, Ecological & Archaeological: [delete as applicable]			
Contaminated Land	No	Hazardous & Controlled Wastes	No
Invasive Weeds [e.g. Japanese Knotweed]	No	Watercourses, Rivers & Streams	Yes
Protected Trees & / or Monuments	No	Protected Species & / or Habitats	No
Archaeology	No	Other [state below]	Yes
Watching Briefs Required	No	Watercourse River- River Dee	

Welfare Facilities & Arrangements: [delete as applicable]			
Static Units	Yes	Location	Site Compound
Mobile Units	No	Location	Site Compound
Facilities Available – Toilets	Yes	Facilities Available – Rest Area	Yes
Facilities Available – Hand washing	Yes	Facilities Available – Drying Room	Yes
Facilities Available – Showers	Yes	Other:	

Sub-contractors & 3 rd Party Impacts, Communication or Co-ordination Requirements: [delete as applicable]		
Traffic Management	Yes	Diverted/ Managed to Pedestrian Path/Walkway Right of Way Construction Access to Via Copart Land Parcel to Auger Boring Exit and Headwall Install Location.
Wide or Abnormal Loads [state]	No	N/A
Emergency Arrangements [state]	Yes	As Per Below
Exclusion Zones [state]	Yes	Excavator Working/ Excavation Area Exclusion Zones to be Established Controlled Construction Plant Works Access Crossing Point
Statutory Undertakers & Services [state]	Yes	Statutory Line Search with Combine Utilities Model (To be provided)

Emergency Arrangements:	
Accidents & Incidents reported immediately to:	MYCO Project Manager- TBC

HEALTH AND SAFETY
METHOD STATEMENT

<p>Site Medical Emergency Arrangements:</p>	<p>In the event of an incident resulting in SERIOUS INJURY or the requirement for attendance by the EMERGENCY SERVICES, send for attendance by a FIRST AIDER and IMMEDIATELY CONTACT: 999,</p> <p>CLEARLY inform them of your Location and the Project Address [see above], where applicable, the nearest gate or Rendezvous Point;</p> <p>On completing emergency services notification and attendance by the First Aider, inform your SUPERVISOR and the SITE MANAGEMENT to ensure they are aware an Emergency Vehicle will be attending site;</p> <p>In the event of an incident resulting in injury requiring First Aid treatment only, contact the SITE FIRST AIDER and your SUPERVISOR;</p> <p>ALL ACCIDENT & INCIDENTS must be NOTIFIED to the SITE MANAGEMENT team and the MYCO HSEQ Manager</p>
<p>Site Accident & Emergency Arrangements:</p>	<p>Near Accident & Emergency Hospital- Countess of Chester Hospital</p> <p>Address: Countess of Chester Hospital NHS Foundation Trust, The Countess Of Chester Health Park, Liverpool Rd, Chester, CH2 1UL</p> <p>Tel: 01244 365000</p>

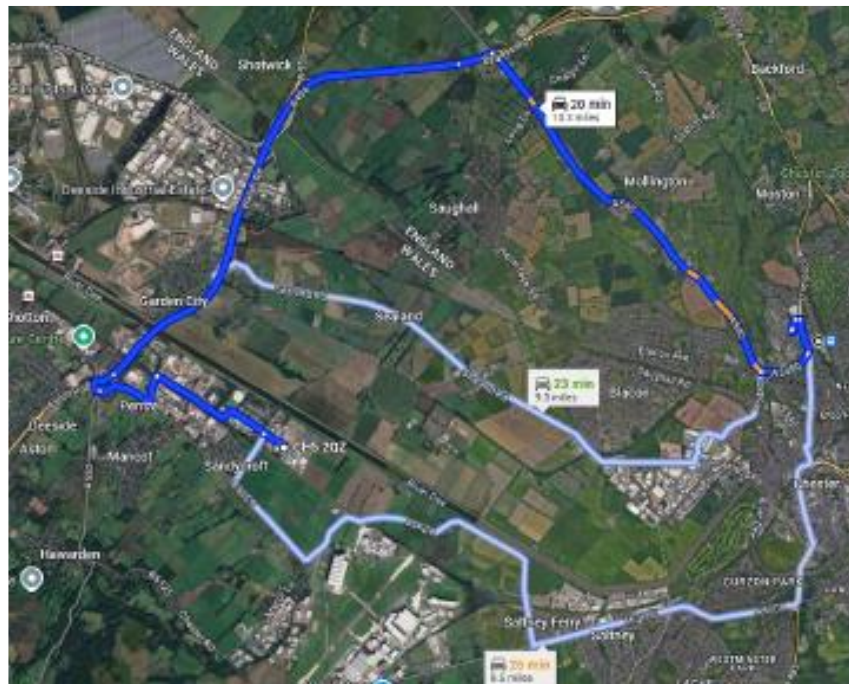

HEALTH AND SAFETY

METHOD STATEMENT

Emergency Contacts			
Police, Fire, Ambulance - Emergency	999		
Police – Non-Emergency	112		
HSE – Office Hours - For major injuries or fatalities only. All other enquiries to be done online	0845 3009923		
HSE – Out of Office Hours - Only contact if incident involves Death, Multiple Casualties, Major Disruption involving closure of roads, large numbers of people going to hospital	0151 9229235		
Gas (National Number)- Wales & West Utilities	0800 111 999		
Water- Dwr Cymru	08000 520145		
Sewage- Dwr Cymru	08000 520145		
Electricity- SP Energy networks	08000 326990		
Natural Resource Wales (Emergency Number)	03000 65 3000		
Environment Agency (National Number)	08708 506506		
First Aiders:	1. TBC	2.	3.
Site Fire Emergency Arrangements:	Telephone:		
Fire Wardens	1. TBC	2.	3.
Site Environmental Emergency Arrangements:	Telephone: TBC		

Project Specific Requirements or Any Other Business Applicable to Works:
<ul style="list-style-type: none"> • MYCO supervisors to attend daily DAB's co-ordination meetings, all deliveries / collections to be briefed • All Deliveries/Collections must be booked in via the project DMS.

Methodology Risk Summary & Assessment:			
Site Specific Risk Assessments: [see Appendix for Risk Assessments – where available]			
Risk Assessment Title:	Risk Assessment Number:	Completed By:	Issue Date:
Proposed Drainage Outfall Pipe Construction Beneath Existing Flood Bund	RA-CCS-001	Luke Linehan	29.05.2025
Key Task Specific Risks: [insert key risks as identified within the site specific risk assessment]			
<ul style="list-style-type: none"> • Plant Movement/ Operations • Buried Statutory Services • Excavations 			

HEALTH AND SAFETY

METHOD STATEMENT



Methodology Risk Summary & Assessment:		
<ul style="list-style-type: none"> Lifting Operations Working from Height Safe Access & Egress Pedestrian Segregation Slip & Trips Noise, Dust & Vibration Working Adjacent to a Live Watercourse 		
Potential Severity of Work Activity: [strikethrough as applicable]		
First Aid Incident	Lost Time Incident / RIDDOR	Major / Fatality
Likelihood of Harm from Work Activity: [strikethrough as applicable]		
Unlikely	Possible	Probable
Numbers of Workers Exposed to Hazards: [strikethrough as applicable]		
1 to 5	6 to 15	15-plus
Overall Risk AFTER Controls: [strikethrough as applicable]		
LOW	MEDIUM	HIGH

Method Statement Communication		
Communication Methods:		
Method Statement Briefing – to be completed prior to the commencement of the works	DABS or Pre-start Briefing – prior to the start of works daily, the Site Supervisor responsible for the works will brief the operatives on the planned and scheduled works – re-iterating the safe systems of work to be employed;	
Person[s] Responsible for Communication:		
Name: TBC	Name:	Name:
Position:	Position:	Position:
Company:	Company:	Company:

Method Statement Monitoring & Compliance:		
Monitoring of compliance with the above method statement will be completed by:		
Name: Luke Linehan	Name:	Name:
Position: Operations Manager	Position:	Position:
Persons authorised to update & amend above method statement:		
Name: Luke Linehan	Name:	Name:
Position: Operations Manager	Position:	Position:

HEALTH AND SAFETY

METHOD STATEMENT

Method Statement Quality Control:			
Prepared by:	Name: Luke Linehan	Signed: 	Date: 29.05.2025
Reviewed by:	Name: Luke Linehan	Signed: 	Date: 29.05.2025

HEALTH AND SAFETY

METHOD STATEMENT



Appendices:	
Appendix 01	Risk Assessments
Appendix 02	Current Design Drawings
Appendix 03	MYCO Works Layout Plan
Appendix 04	RAMS Briefing Register

HEALTH AND SAFETY

METHOD STATEMENT

Appendix 01	Risk Assessments
-------------	------------------

HEALTH AND SAFETY ACTIVITY RISK ASSESSMENT

Project Name & No.:	Copart Sandycroft – MYCO-001	Risk Assessment No.:	RA-CCS-001
Risk Assessment Title:	Proposed Drainage Outfall Pipe Construction Beneath Existing Flood Bund	Revision No.:	REV 01
Specific Location of Works:	Land East Adjacent to Copart, Sandycroft, Flintshire, CH5 2QZ	Anticipated Start Date of Works:	TBC
Scope & Description of the Works:	Trenchless Drainage Outfall Construction Beneath Existing Flood Bund Utilising Guided Auger Boring consisting of: <ul style="list-style-type: none"> • Prestart Inspection & Mobilisation • Establishment of Working Areas • Auger Boring Launch Shaft Construction (Entry Side) & Auger Boring Termination Temporary Excavation (Exit Side) • Auger Boring Machine Setup- Machine Placement, Line and Level Establishment, Prestart Checks & Pilot Rod Installation • Auger Boring Drilling & Pipe Installation • Precast Concrete Headwall Construction • Demobilisation 		
Associated Documents:	Method Statement MS-CCS-001, Works Plan MYCO-CCS-002		
Risk Assessment Completed by:	Name: Luke Linehan	Signed: 	Date: 29.05.2025
Risk Assessment Reviewed by:	Name: Luke Linehan	Signed: 	Date: 29.05.2025

Likelihood Rating Key:		Severity Rating Key:		Severity Rating						
					5	4	3	2	1	
5	Frequent [1 or more per week]	5	Multiple or Single Fatality or Collapse of Structure	Likelihood Rating	5	25	20	15	10	5
4	Probable [1 per month]	4	Major Injury or Major Damage to Property		4	20	16	12	8	4
3	Occasional [1 per year]	3	Reportable Lost Time Injury or Significant Damage to Property		3	15	12	9	6	3
2	Remote [1 in 10 years]	2	Other Lost Time Injury or Damage to Property		2	10	8	6	4	2
1	Improbable [1 in 100 years]	1	Minor Injury		1	5	4	3	2	1
Residual Risk Rating Matrix Key:										

HEALTH AND SAFETY

ACTIVITY RISK ASSESSMENT

12 – 25:	Unacceptable level of risk. Risk level MUST be reduced. Operations WILL NOT proceed until the level of risk is reduced to an acceptable level. Requirement for the works need to be reviewed and alternative methodologies investigated where risk cannot be reduced to an acceptable level.
5 – 11:	Risks acceptable where principles of prevention have been applied and control measures implemented to reduce risk so far as is reasonably practicable. Activity, operation or works creating the hazard and risk must be managed and supervised to ensure continued effectiveness and compliance with the control measures.
1 – 4:	Acceptable level of risk. Risk associated with the hazard is considered to be of an acceptable level. Continual reviews to confirm hazards and risks remain adequately controlled.

1: Activity & Hazard Description	2: Person[s] at Risk	3: Potential Consequence[s]	4 – 6: Initial Risk Rating			7: Control Measure[s]	8: Person[s] Responsible for Implementation & Monitoring	9 – 11: Residual Risk Rating		
			L	S	IRR			L	S	RRR
Traffic control / Vehicle Movement & Pedestrian Controls Risk from; Contact Vehicles / Pedestrians Slips, Trips & Falls Impact with Vehicles	Banksman Slinger/signaller Site operatives Plant Driver	Death Serious injury Trapping body / Major Injury, Fatality Serious damage to plant or equipment	4	5	20	<ul style="list-style-type: none"> Prior to the start of works, a Traffic Management Plan to be produced with PC Mace Plans with project specific liaison with the local council; Pedestrians and vehicles are always to be kept separate. Where pedestrians and vehicles do need to work in the same area, works to be prioritized, and vehicles to be moved and controlled by a vehicle marshal or banksman; Pedestrian routes to be kept clear of materials and products; All employees to be trained and supervised including plant / vehicle operators to ensure only competent persons operate plant and equipment High visibility PPE to be worn by all to ensure persons are visible in all conditions; Adequate signage and guarding in place to ensure all persons are aware of pedestrian and traffic routes Regular review of plan to ensure relevance and all works are reflective of operations Speed limits in place to minimize risk of speeding; Reversing minimized to restricted area and controlled by use of banksman Vehicles equipped with safety and warning devices – flashing beacons, beepers etc. Ensure plant is certified, maintenance and checked daily by operator Record of inspection to be filled out weekly Suitable machinery for the intended operations must be selected. A competent Operator with appropriate CPCS card for the machine type must be used. The Manufacturer’s handbook/Operators manual is to be kept with the excavator. Ground conditions are to be assessed before each use. Ground/formation must be capable of supporting the machine. 	Site Supervisor is responsible. Monitoring; By site manager.	1	5	5

HEALTH AND SAFETY ACTIVITY RISK ASSESSMENT

1: Activity & Hazard Description	2: Person[s] at Risk	3: Potential Consequence[s]	4 – 6: Initial Risk Rating			7: Control Measure[s]	8: Person[s] Responsible for Implementation & Monitoring	9 – 11: Residual Risk Rating		
			L	S	IRR			L	S	RR R
						<ul style="list-style-type: none"> The safe working load (SWL) or rated capacity must be clearly marked on the Excavator. Inspect the machine before use. Report any defects immediately. DO NOT use a defective machine. Any defective machines are to be quarantined pending examination, repair or removal from site. An exclusion zone is to be established around the work area and slew radius to be kept clear from obstructions. 360deg cameras to be fitted on required plant 				
Fuel & Re-Filling Risk from; Fire, Explosion due to exposure of flammables to source of ignition; Environmental Contamination; Contact with Skin;	Site Operatives	Major Injuries; Fatalities; Occupational Health illness i.e. Dermatitis;	4	4	16	<ul style="list-style-type: none"> No smoking Switch off engines, lights and mobile phone Use only approved containers to carry diesel i.e. jerry cans Use funnel to prevent spillages Drip trays placed at base of equipment being refuelled Spill kit positioned in easily accessible location Correct disposal of contaminated material Lock diesel bowser when not in use, including transportation Impermeable overalls with chemical resistant overalls worn Impermeable gantlets to be worn Impermeable boots worn Wash immediately if diesel contacts skin or eyes [seek medical attention if irritation persists]; Avoid rubbing skin while wearing gantlets Change clothes at end of shift Clean clothes at start of shift must be worn Wash skin regularly and apply barrier cream at start of shift and after breaks Remove overalls and other related PPE during breaks to allow skin to breath Shower at end of shift No refuelling to be under taken with 25m of any Watercourse. 	Implementation; Construction Manager; Site Supervisor; Monitoring; Project Manager; HSEQT Advisor;	1	4	4
						<ul style="list-style-type: none"> 				

HEALTH AND SAFETY ACTIVITY RISK ASSESSMENT



1: Activity & Hazard Description	2: Person[s] at Risk	3: Potential Consequence[s]	4 – 6: Initial Risk Rating			7: Control Measure[s]	8: Person[s] Responsible for Implementation & Monitoring	9 – 11: Residual Risk Rating		
			L	S	IRR			L	S	RR R
						•				
Lifting Operations; Risk from; Fall of materials, Impact, Collapse	Banksman Slinger/signaller Plant Driver Site Operatives	Major Injuries, fatalities	4	5	20	<ul style="list-style-type: none"> Adequate planning of all lifting operations by trained and competent persons. Recorded and communicated to personnel via lift plans and SOCL; Lifting operations suitably supervised; Register of all plant maintained and maintenance carried out All plant and lifting equipment maintained and certificated All lifting equipment must be visually inspected before use and inspections recorded on weekly basis as per LOLER regs All equipment suitable for specific task All operators competent and certificated Operations fenced off No lifting over any person/public Inspect the excavator before use and lifting accessories, including the lifting point, before use to ensure they are not damaged or worn. Report defects immediately. DO NOT use a defective machine. All lifting under slinger/signaller control 	Persons Responsible for Implementation; Project Manager, Construction Manager, Site Supervisor, Gang Supervisor, Monitoring; HSEQT Advisor, Contracts Manger	2	5	10
Excavators Used as Cranes; Overturning Strike by swinging loads	Plant operator Slinger Signaller Other operatives in vicinity	Fatality Serious Injury Plant and structural damages	4	5	20	<ul style="list-style-type: none"> Compliance with SWL. Well-maintained, certified & tested equipment. Daily pre-use checks. Statutory inspections & tests. Loads carried close to ground. Guidelines used where appropriate to steady load. Competent operators 	Appointed Person Crane Supervisor Slinger Signaller Plant Operator Plant Manager	1	5	5
Planning & Competence;	Plant operator Slinger Signaller Other operatives in vicinity	Fatality Serious Injury Plant and structural damages	4	5	20	<ul style="list-style-type: none"> Operations to be carried out under a lifting plan, method statement and risk assessment; CPCS Appointed Person, Slinger Signaller and where required Lifting Supervisor used for all operations; Equipment supplied must be as requested and in line with the LP. Substituted equipment and specifications must not be made; 	Appointed Person Crane Supervisor Slinger Signaller Plant Operator Plant Manager	2	5	10

HEALTH AND SAFETY ACTIVITY RISK ASSESSMENT



1: Activity & Hazard Description	2: Person[s] at Risk	3: Potential Consequence[s]	4 – 6: Initial Risk Rating			7: Control Measure[s]	8: Person[s] Responsible for Implementation & Monitoring	9 – 11: Residual Risk Rating		
			L	S	IRR			L	S	RR R
						<ul style="list-style-type: none"> All works will be completed in line with the developed Schedule of Common Lifts as issued with the lifting plan; 				
Unplanned release of product or failure of equipment / accessories;	Plant operator Slinger Signaller Other operatives in vicinity	Fatality Serious Injury Plant and structural damages	4	5	20	<ul style="list-style-type: none"> A current LOLER certificate required for all lifting appliances and accessories used All equipment used must be within SWL required and configurations checked (i.e. down rating based on slinging technique) SWL of equipment to be checked prior to use. Equipment visually checked prior to use to ensure fit for purpose; Use correct equipment as specified in Lifting Plan, ensure equipment is protected from sharp edges or corners that could damage / weaken equipment; Ensure loads are free from loose equipment and materials; Test lift prior to completing lift of equipment to ensure loads is stable and balanced; 	Appointed Person Crane Supervisor Slinger Signaller Plant Operator Plant Manager	2	5	10
Underground services, unsuitable foundations, ground stability	Plant operator Slinger Signaller Other operatives in vicinity	Fatality Serious Injury Plant, infrastructure and structural damages	4	5	10	<ul style="list-style-type: none"> All underground services, structures and voids identified prior to positioning and placement of the equipment; Level ground and working area to be provided from site entrance to working area, suitable for cranes, delivery lorries and equipment to travel to works area; 	Appointed Person Crane Supervisor Slinger Signaller Plant Operator	1	5	5
Persons struck by plant and equipment	Plant operator Slinger Signaller Public Other operatives in vicinity	Fatality Serious Injury	5	5	25	<ul style="list-style-type: none"> No persons to stand or work within the operating area required for lowering load, without the authority of the operator and slinger – this should only be allowed when there is a genuine reason for their presence; When attaching a load of completing any slinging operations around the boom of the excavator, 'dead man's handle' must be engaged to prevent movements; Working exclusion zone installed around the excavator to prevent persons accessing the working area and potential crushing; 600mm crush zone to be maintained in all areas; Operatives to ensure they are not standing in crush zones during lifting operations. Tag lines used to control movement of materials; 	Crane Supervisor Slinger Signaller Plant Operator	2	5	15

HEALTH AND SAFETY ACTIVITY RISK ASSESSMENT



1: Activity & Hazard Description	2: Person[s] at Risk	3: Potential Consequence[s]	4 – 6: Initial Risk Rating			7: Control Measure[s]	8: Person[s] Responsible for Implementation & Monitoring	9 – 11: Residual Risk Rating		
			L	S	IRR			L	S	RR R
						<ul style="list-style-type: none"> Additional Banksman provided to control work areas and assist with movements of materials for ground to high level operations. 				
Trapping of fingers and limbs in chains or taglines	Slinger Signaller	Serious Injury	5	4	25	<ul style="list-style-type: none"> Hands and fingers are to be kept out of the crush zones and outside of the internals of the chains to ensure fingers do not get pulled in or trapped; Hiab operator not to start lifting until slinger signaller is away from the items being carried / lifted; 	Slinger Signaller Plant Operator	3	4	12
Fall from height during slinging activities – accessing the lifting points	Slinger Signaller	Fatality Serious Injury	5	5	25	<ul style="list-style-type: none"> Suitable access arrangements must be provided to ensure slingers are able to access the working areas safely and without risk of falls from height. Protective scaffold platforms, proprietary vehicle edge protection systems and / or safety harnesses to be used to prevent operatives falling from height; 	Appointed Person Crane Supervisor Slinger Signaller Plant Operator	2	5	10
Moving Machinery	Plant operator Site operatives Slinger	Fatality Serious Injury Property Damage	4	5	20	<ul style="list-style-type: none"> All public/sensitive areas to be 'zoned' off completely from crane movements. All slingers/ signalers to be aware of crane movements before commencing all lifts. Liaise with other contractors during coordination meetings of intended movements. 	Appointed Person Crane Supervisor Slinger/signaler Plant operator	2	5	10
Suspended Loads	Plant Operator Site Operatives Slinger	Fatality Serious Injury	5	5	25	<ul style="list-style-type: none"> Lifting Exclusion Zone to be establish around works area to prevent any unauthorized access. Awareness during project briefing to under no circumstances are operatives to walk under any load being suspended. Excavator Operator to ensure that all operatives are clear of crane movement and lifting loads during operating works. 	Appointed Person Crane Supervisor Slinger/signaler Plant operator Operatives	2	5	10
						<ul style="list-style-type: none"> 				
Completion of general operations in and around excavations;	Site operatives;	Crush / impact injuries due to collapsed excavation;	5	5	25	<ul style="list-style-type: none"> All excavations will be monitored, assessed and inspected by a competent supervisor at the start of every shift, after significant change, modification or change that could have an effect on ground stability; 	Persons Responsible for Implementation; Project Manager,	3	5	15

HEALTH AND SAFETY ACTIVITY RISK ASSESSMENT

1: Activity & Hazard Description	2: Person[s] at Risk	3: Potential Consequence[s]	4 – 6: Initial Risk Rating			7: Control Measure[s]	8: Person[s] Responsible for Implementation & Monitoring	9 – 11: Residual Risk Rating		
			L	S	IRR			L	S	RR R
Collapse of Excavation;		Fatality;				<ul style="list-style-type: none"> No persons will enter an unsupported, un-stepped or unbattered excavation; Excavations will be supported [trench boxes, sheets etc], stepped or battered back as identified by the competent supervisor and Temporary Works Design; All materials excavated will be placed at least 1.5m away from the working area to prevent surcharge of excavation; Where plant is working alongside, tipping material into excavations, suitable support will be provided to prevent collapse; 	Construction Manager, Site Supervisor, Gang Supervisor, Monitoring; HSEQT Advisor, Contracts Manger			
Completion of general operations in and around excavations; Placement of material into excavation;	Site operatives;	Struck by falling materials; Overturning of plant; Crush injuries;	3	4	12	<ul style="list-style-type: none"> Where plant is working alongside, tipping into excavations, suitable support will be provided to prevent collapse; refer to Temporary works design; Stop blocks placed to prevent plant overturning into excavation; Operatives must exit or stand a safe distance away during placement of material; 	Persons Responsible for Implementation; Project Manager, Construction Manager, Site Supervisor, Gang Supervisor, Monitoring; HSEQT Advisor, Contracts Manger	1	4	5
Completion of general operations in and around excavations; Access / egress into excavations; Unauthorised access	Site operatives; Unauthorised persons;	Slip and trips during access / egress;	5	5	25	<ul style="list-style-type: none"> Proprietary access steps installed to create safe means of access / egress. Or where temporary works elements are used wooden ladders will be provided and will remain in place when operatives are in excavations; All ladders and access steps will be secured to prevent movement during use; Where practicable ladders giving access into excavations will be removed where deemed necessary; Support props will not be used for access or egress; A clear access path and route will be maintained around the excavation; Ensure that working area is sufficiently illuminated and there are no hazards under foot; Ensure clear working area for operatives, keep all hand tools and equipment to a minimum, employ good housekeeping practices; Ground installed for plant and pedestrian safe access and egress 	Persons Responsible for Implementation; Project Manager, Construction Manager, Site Supervisor, Gang Supervisor, Monitoring; HSEQT Advisor, Contracts Manger	2	3	6

HEALTH AND SAFETY ACTIVITY RISK ASSESSMENT

1: Activity & Hazard Description	2: Person[s] at Risk	3: Potential Consequence[s]	4 – 6: Initial Risk Rating			7: Control Measure[s]	8: Person[s] Responsible for Implementation & Monitoring	9 – 11: Residual Risk Rating		
			L	S	IRR			L	S	RR R
						<ul style="list-style-type: none"> Dewatering sump and pump for all excavation dewatering Installed works secured segregation fencing 				
Completion of general operations in and around excavations; Falling of persons / material into excavation;	Site operatives; Site visitors;	Major injuries caused by falling from height; Struck by falling materials;	4	5	20	<ul style="list-style-type: none"> Localised fencing and physical barriers will be placed around excavations and will be closed whenever the excavation is left unattended; Where temporary works is used, proprietary edge protection installed with integrated toe boards; Excavations will be backfilled at the earliest opportunity; Localised signage and warning notices of excavations will be fixed to fencing; All materials excavated will be placed at least 1.5m away from the working area to prevent materials falling into the excavation; Materials will be loaded on the downhill side of excavations; Any boulders or loose material will be sealed into spoil heap using the excavator; 	Persons Responsible for Implementation; Project Manager, Construction Manager, Site Supervisor, Gang Supervisor, Monitoring; HSEQT Advisor, Contracts Manger	2	4	8
Completion of general operations in and around excavations; Weils disease;	Site operatives;	Serious illness; Fatality;	3	3	9	<ul style="list-style-type: none"> Good hygiene practice to be adopted by all. Wash before eating and / or smoking; Raise awareness and communicate the risks of Weil's disease and the symptoms; Suitable impermeable gloves to prevent contamination of undergarments. Keep non-work clothes separate from work gear to avoid cross contamination; Protective clothing, footwear and equipment etc. must be cleaned after use; Any cuts or abrasions to be treated by first aider immediately and waterproof plaster applied; Ensure all food waste is placed in sealed bins and regularly removed. Food must not be left exposed and must be suitably stored; Information cards provided to those potentially at risk of contracting Weil's disease; 	Persons Responsible for Implementation; Project Manager, Construction Manager, Site Supervisor, Gang Supervisor, Monitoring; HSEQT Advisor, Contracts Manger	1	4	4

HEALTH AND SAFETY ACTIVITY RISK ASSESSMENT



1: Activity & Hazard Description	2: Person[s] at Risk	3: Potential Consequence[s]	4 – 6: Initial Risk Rating			7: Control Measure[s]	8: Person[s] Responsible for Implementation & Monitoring	9 – 11: Residual Risk Rating		
			L	S	IRR			L	S	RR R
<p>Completion of general operations in and around excavations;</p> <p>Working around contaminated land and / or water;</p>	Site operatives;	<p>Serious illness;</p> <p>Fatality;</p>	3	3	9	<ul style="list-style-type: none"> Review pre-construction information to identify any potential 'hot spots' / contaminated areas; Where operations completed on brown field sites, operatives will receive a minimum of CAT A training; Good hygiene practice must be adopted by all. Wash hands before eating and / or smoking; Information provided and communicated to operatives on health risks and controls; Impervious gloves, wellingtons and disposable overalls [PVC in wet conditions] to prevent contamination of undergarments. Keep non-work clothes separate from work clothes / gear to avoid cross contamination; Where risk of inhalation of contaminants is present, RPE will be worn, suitable to the contamination present and exposure; Establish of 'clean' and 'dirty' areas with controlled access / egress points; Any cuts or abrasions to be treated by first aider immediately and waterproof plaster applied; Report any health symptoms e.g. headaches, stomach aches to the first aider and supervisor; Report any discoveries of suspicious materials e.g. organic material, discolouring of ground, smells etc. to project manager / supervisor; Water suppression used during dry days to prevent contaminants from becoming air borne and spreading through the site; 	<p>Persons Responsible for Implementation; Project Manager, Construction Manager, Site Supervisor, Gang Supervisor,</p> <p>Monitoring; HSEQT Advisor, Contracts Manger</p>	1	5	5
<p>Work at height;</p> <p>Working on Scaffold work platform;</p> <p>Unauthorised Access</p>	<p>Site operatives;</p> <p>Unauthorised persons;</p>	<p>Struck by falling tools / materials;</p> <p>Major injury due to fall from height;</p> <p>Fatality;</p>	3	4	12	<ul style="list-style-type: none"> Work scaffold platforms placement or assembly by a trained and competent operatives; Where ladders form the access point onto the first level of a scaffolding or working platforms, in order to prevent unauthorised access, the ladders should be removed and secured or covered in such a way it denies access to any of the rungs; Toe boards in place to prevent materials falling from height or if not possible then materials must be stored an adequate distance from the edge to prevent them from being kicked or knocked over the edge; Visual checks completed on edge protection daily to ensure suitability; 	<p>Persons Responsible for Implementation; Project Manager, Construction Manager, Site Supervisor, Gang Supervisor,</p> <p>Monitoring; HSEQT Advisor, Contracts Manger</p>	2	3	6

HEALTH AND SAFETY ACTIVITY RISK ASSESSMENT

1: Activity & Hazard Description	2: Person[s] at Risk	3: Potential Consequence[s]	4 – 6: Initial Risk Rating			7: Control Measure[s]	8: Person[s] Responsible for Implementation & Monitoring	9 – 11: Residual Risk Rating		
			L	S	IRR			L	S	RR R
						<ul style="list-style-type: none"> Regular inspections carried out in accordance with statutory requirements on handrails and recorded with any defects corrected by a trained and competent scaffolder; Scaff-tag system in place to provide visual conformation of inspection; Modifications / adjustments to edge protection to only be carried out by a trained and competent scaffolder; Equipment / tools must not be stored on handrails. Materials must be stored at least 1m from edge protection; Good levels of housekeeping maintained at all times; 				
Plant Operations; Operating 360 Tracked / wheeled excavator Plant movement and completion of works adjacent to site operatives and / or other trade contractors;	Site operatives; Other trade contractors;	Struck by falling spoil / material; Major impact or crush injury;	3	5	15	<ul style="list-style-type: none"> Exclusion zone set up around work area to restrict access to pedestrians around plant; Operatives must not enter the operating radius of the excavator. Refer to yellow, amber and red zones; refer to Careys safe zone poster for guidance Excavator bucket or arm must not be slewed over persons, vehicles, cabins or buildings; All mirrors will be altered to reduce blind spots and where available, CCTV systems used to reduce blind spots; A minimum clearance of 600mm to be maintained between any part of the machine [particularly the excavator tail] and any obstruction; Where visibility is restricted, other trade contractors, pedestrians and / or workforce are present, a competent and trained banksman will control plant movement; No persons are allowed to stand or work within the operating radius without the operator's permission; Operatives must remain within eye contact of plant operative - no blindside operations or access. Operatives accessing work areas must be acknowledged [thumbs up]; 	Construction Manager, Site Supervisor, Gang Supervisor,	1	5	5
Plant Operations; Operating 360 Tracked / wheeled excavator Breaking out concrete obstructions utilising pneumatic attachment;	Site operatives; Other trade contractors; Public;	Struck by flying debris; Eye injury; Temporary threshold shift;	4	5	20	<ul style="list-style-type: none"> Equipment checked before use; Screens to be erected alongside works where risk of material ejection could cause injury or damage; Acoustic barriers attached to Heras panels where identified in noise assessment; Appropriate signage to be displayed; Banksman / operatives working within vicinity must stand a suitable distance away from breaking operations where 	Construction Manager, Site Supervisor, Gang Supervisor,	2	3	6

HEALTH AND SAFETY ACTIVITY RISK ASSESSMENT

1: Activity & Hazard Description	2: Person[s] at Risk	3: Potential Consequence[s]	4 – 6: Initial Risk Rating			7: Control Measure[s]	8: Person[s] Responsible for Implementation & Monitoring	9 – 11: Residual Risk Rating		
			L	S	IRR			L	S	RR R
		Occupational deafness; Tinnitus;				<p>not possible operatives must wear face visors or eye protection to Grade 1 impact, BS EN 166B;</p> <ul style="list-style-type: none"> Noise assessment produced to determine suitable hearing protection and control measures; Hearing protection must be worn to grade BS EN 352 with the suitable SNR value as identified in the noise assessment; Hearing protection will be made available to all those visiting or working in the area; 				
Plant Operations; Operating 360 Tracked / wheeled excavator Surcharging excavation edge;	Plant operator; Site operatives;	Collapse of excavation sides; Over turning of plant; Major injuries; Fatality;	3	5	15	<ul style="list-style-type: none"> No persons will enter an unsupported, unbenced or unbattered excavation; Excavations will be supported [trench boxes, sheets etc.], benced or battered back as identified by the temporary works design or competent supervisor / engineer; All materials excavated will be placed a minimum of 1.5m away from the working area to prevent surcharge of excavation or as stated by the TW's design; Plant operations and haul roads will be located away from excavations; Where plant is working alongside excavations, suitable support will be provided to prevent collapse as stated in the TW's design; Stop blocks placed or earth bund created to prevent plant from overturning into excavations; Documented excavation inspections completed by TW's supervisor before works commence, after significant change, modification or change that could change ground stability; 	Construction Manager, Site Supervisor, Gang Supervisor,	1	5	5
Use of power and hand tools and equipment;	Site Operatives;	Minor cuts and abrasions; Major Injuries; Contact with abrasive wheel; Debris entering eye; HAV's syndrome;	4	4	•	<ul style="list-style-type: none"> Inspect tools and equipment regularly for signs of damage / worn parts. Must be removed from service if damaged; Ensure correct tools and equipment are used for task; Only 110v must be used on site; Cables and electrical tools must be inspected before use and have a valid PAT test sticker attached for visual identification for operatives using the tool; Cables must not trail through walkways and work areas which may cause STF's; 	Project Manager; Supervisor; HSEQ Advisor [monitor]	2	4	8

HEALTH AND SAFETY ACTIVITY RISK ASSESSMENT



1: Activity & Hazard Description	2: Person[s] at Risk	3: Potential Consequence[s]	4 – 6: Initial Risk Rating			7: Control Measure[s]	8: Person[s] Responsible for Implementation & Monitoring	9 – 11: Residual Risk Rating		
			L	S	IRR			L	S	RR R
						<ul style="list-style-type: none"> Only trained and competent operatives to use and change abrasive wheels; Correct wheel / disc attached for the task with safety information to identify RPM; Once wheel is worn to the safety information, the wheel must be disposed; Use of suitable and well-maintained guards which must never be removed; Health surveillance completed through the use of the HAVs register when using equipment that generates vibration; Operatives must not be exposed to vibration for long periods of time and must rotate regularly; PPE required for the task will be supplied at no cost; Mandatory and task specific PPE must be worn e.g. safety glasses, gloves, ear protection etc.; 				
Erecting Fence & Manual Handling; Risk from; Manual Handling & Lifting Heavy / Awkward Loads Cuts	Site operatives	Muscular skeletal injuries Back Injury	3	3	9	<ul style="list-style-type: none"> Materials to be placed as close to the working area as possible and where possible. All staff trained in manual handling techniques to ensure good lifting techniques completed Assessment of manual handling risks carried out to reduce load sizes and or material sizes Training of Operatives Use Mechanical Aids Use two or more men for heavy / awkward loads and the correct lifting techniques. Heavy items placed at ground level or level where lifting is assisted PPE worn including gloves, to prevent hand injuries; 	Site Supervisor is responsible. Monitoring; Supervisor during operations.	1	3	3
Manual Handling; Manoeuvring and placing Equipment	Site Operatives	Muscular-skeletal injuries Back Injury	4	4	16	<ul style="list-style-type: none"> Manual handling will only be used where it is not practicable to use mechanical aids or the items are below 25Kg. All Drills and Rigs are be broken down into components of less than 25kg Operatives to used mechanical aid or mechanical plant to location to plant to works area. All staff trained in manual handling techniques to ensure good lifting techniques completed Repetitive motions are to be avoided. 	Supervisor	2	3	6

HEALTH AND SAFETY ACTIVITY RISK ASSESSMENT



1: Activity & Hazard Description	2: Person[s] at Risk	3: Potential Consequence[s]	4 – 6: Initial Risk Rating			7: Control Measure[s]	8: Person[s] Responsible for Implementation & Monitoring	9 – 11: Residual Risk Rating		
			L	S	IRR			L	S	RRR
						<ul style="list-style-type: none"> Assessment of manual handling risks carried out to reduce load sizes and or material sizes Training of Operatives Manual Handling Training 				
Cutting, Planning, Breaker and Coring; Noise	Site Operatives Environment Public;	Hearing Damage	5	3	15	<ul style="list-style-type: none"> Reduce the exposure by choosing the most suitable and quiet piece of equipment where ever possible. Suitable hearing protection is to be worn at 80 decibels or above. Switch off plant or tools when not in use 	Site Manager / Supervisor / Foreman Monitoring; Supervisor during operations	1	3	3
Cutting, Planning, Breaker and Coring; Dust	Site Operatives Environment Public;	Damage to health Respiratory or major illness Environmental damage	5	4	20	<ul style="list-style-type: none"> Dust suppression to be used via water pump bottle or continual water supply hose. RFE Face fit masks or overhoods FFP3 standard to be used by operatives Suitable equipment for task Adequate dust suppression must be in place and used at all times. If the suppression blocks or the water has run out then cutting must stop immediately Adequate dust masks shall be provided and used at all times by the user or anyone else who may be in the immediate vicinity. (FFP3 or JSP press to check mask) 	Site Manager / Supervisor / Foreman Monitoring; Supervisor during operations	2	4	8
Cutting, Planning, Breaker and Coring; Vibration	Site Operatives Environment Public;	White Finger	4	4	16	<ul style="list-style-type: none"> Operatives are to be provided with the correct and appropriate training. Work is to be planned to ensure exposure limits are not exceeded. Exposure limits, average magnitudes and usage times are to be indicated on the tools. Regular maintenance of all equipment is to be carried out. All plant defects are to be reported. Job rotation is to be considered. Individual daily exposure to be recorded and monitored on the HAVS registers filed in the stores. Operatives will ensure that the EAV limits are not exceeded for the drills used. Self-feed rigs to minimise contact with the drill. 	Site Manager / Supervisor / Foreman Monitoring; Supervisor during operations	2	4	8

HEALTH AND SAFETY ACTIVITY RISK ASSESSMENT



1: Activity & Hazard Description	2: Person[s] at Risk	3: Potential Consequence[s]	4 – 6: Initial Risk Rating			7: Control Measure[s]	8: Person[s] Responsible for Implementation & Monitoring	9 – 11: Residual Risk Rating		
			L	S	IRR			L	S	RR R
Confined Space; Pre-entry Asphyxiation due to oxygen depletion Poison by toxic substance Fire/Explosion Electrocutation Diseases from animal wastes, infected materials, micro-organisms, fungal infections, Leptospirosis, Tetanus, pigeon excreta and Weils Disease	Site Operatives;	Fatality Serious Injury	4	5	20	<ul style="list-style-type: none"> No risk of Asphyxiation due oxygen depletion, all excavation operations are conducted in virgin ground; No burning operations will be conducted within close proximity of deep excavations which potentially may consume oxygen; No plant will be positioned inside the excavation which may cause the atmosphere to become dangerous; Gas monitors will be placed inside the excavation to monitor the working atmosphere before entry of operatives. In the unlikely event the atmosphere is dangerous, works will cease and the supervisor must be informed; Pumps will be adequately positioned to drain ground water from excavations before access is granted to operatives; Trench / manhole boxes or sheet piles and frames [all installed as per area specific TW's design] will be used to retain ground to prevent the ingress of free flowing substances; Any voids between TW's which may foreseeably allow the access of free-flowing substances will be sealed using sheet piles; No electrical equipment will be used within the excavation; Operatives will never work alone, minimum of 3x persons in a gang at all times; Radios issued to each gang as means of constant communication with entire site; Before operatives are put to work, the individual must complete an occupational health questionnaire to confirm their state of health. This will be reviewed and assessed by the project manager who will deem the individuals suitability and condition to work. All occupational health questionnaires will be submitted to MYCO HR Dept. for further review; Occupational health nurse will complete an assessment on operatives working in excavations to confirm their state of health; Rescue plan in place and regularly reviewed for its suitability Rescue plan briefed to operatives completing operations; Suitable means of access / egress secured onto landings; 	Persons Responsible for Implementation; Project Manager, Construction Manager, Site Supervisor, Gang Supervisor, Monitoring; HSEQT Advisor, Contracts Manger	1	5	5

HEALTH AND SAFETY ACTIVITY RISK ASSESSMENT

1: Activity & Hazard Description	2: Person[s] at Risk	3: Potential Consequence[s]	4 – 6: Initial Risk Rating			7: Control Measure[s]	8: Person[s] Responsible for Implementation & Monitoring	9 – 11: Residual Risk Rating		
			L	S	IRR			L	S	RR R
						<ul style="list-style-type: none"> Access / egress visually inspected before use, with inspections recorded weekly; Adequate lighting must be provided at all times; Operatives to leave excavation upon expiration of natural daylight; Any flue like symptoms must be reported immediately to a doctor and information given about the works completed; 				
Confined Space; Access via ladder (only if access using installed step irons is unsafe) Sliding/ falling Ladder failure Slipping Falls from ladder Incorrect Use Dropping during work causing damage or injury	Site Operatives	Fatality Serious Injury	4	5	20	<ul style="list-style-type: none"> Permit to use ladder must be issued by MYCO prior to commencing works Ensure ladder is secured at top, set ladder on firm and level base Ensure ladder does not exceed 75o angle. Confirm that stays, chains or cords are in good condition. Ensure test regime is in force, separate serviceable from un-serviceable ladders. No painted timber ladders on site. Ensure ladders are cleaned and free from oils and grease. Ensure they are subjected to weekly and pre-user inspections Ensure tools and other equipment secured during use. Ensure ladder is not over-extended. Ensure the ladder is the right type for the job Use ladders of correct length and type for the job. 	Persons Responsible for Implementation; Project Manager, Construction Manager, Site Supervisor, Gang Supervisor, Monitoring; HSEQT Advisor, Contracts Manger	1	5	5
Concreting Operations; Risk Skin contact with concrete;	Site operatives	Skin diseases, Concrete Burns	3	4	12	<ul style="list-style-type: none"> Adequate PPE to be worn – white overalls, gloves, glasses. Refer to COSHH assessments. Adequate washing facilities to be provided. Contact to skin must be immediately washed; 	Persons Responsible for Implementation; Project Manager, Construction Manager, Site Supervisor, Gang Supervisor, Monitoring; HSEQT Advisor, Contracts Manger	1	4	4
Use of Auger bore equipment	Site operatives	Fatality Serious Injury Limbs caught in moving parts resulting in broken	3	3	9	<ul style="list-style-type: none"> Use competent/trained personnel. Equipment/process familiarity. Permit to works Maintain equipment in good order. Plant Safety Guards to be installed and used at all time. 	Site Manager / Supervisor / Foreman Monitoring;	1	3	3

HEALTH AND SAFETY ACTIVITY RISK ASSESSMENT



1: Activity & Hazard Description	2: Person[s] at Risk	3: Potential Consequence[s]	4 – 6: Initial Risk Rating			7: Control Measure[s]	8: Person[s] Responsible for Implementation & Monitoring	9 – 11: Residual Risk Rating		
			L	S	IRR			L	S	RR R
		bones/ crush injuries				<ul style="list-style-type: none"> Routine maintenance. Keep hands clear of moving parts & rams. Work in accordance with Safe System of Work 	Supervisor during operations			
Works near to water course: Risk from drowning	All operatives	Death	3	5	15	<ul style="list-style-type: none"> No lone working Fence off all works area, making a physical barrier between the works area and the water course. Installation of Sandbagged temporary protection wall. Floatation devices to be kept near works area Emergency rescue provision will be put in place via outside of the segregated works area consisting of Lifebuoy and encapsulated throwing line. If any operative requires to be outside of the segregated works area or will setting up the segregated works area they must be wearing a Life Vest, Safety Harness and attached to a fall arrest retriever devise which is attached to a fixed anchor point. Daily briefings to address works close to watercourse. To facilitate safe access/ egress and prevent any surface damage to the flood earth bung surface protection ground matts will be installed where pedestrian or plant movement maybe required. Dewatering pumps will be available if the need arises to dewater any groundwater entering into works excavations. A sump pump must be supplied and discharged into a skip or other receptacle to first permit silts to settle before the pumped water is allowed into the below ground drainage system. 	Site Manager / Supervisor / Foreman Monitoring; Supervisor during operations	1	5	5

HEALTH AND SAFETY

METHOD STATEMENT

Appendix 02	Current Design Drawings
-------------	-------------------------

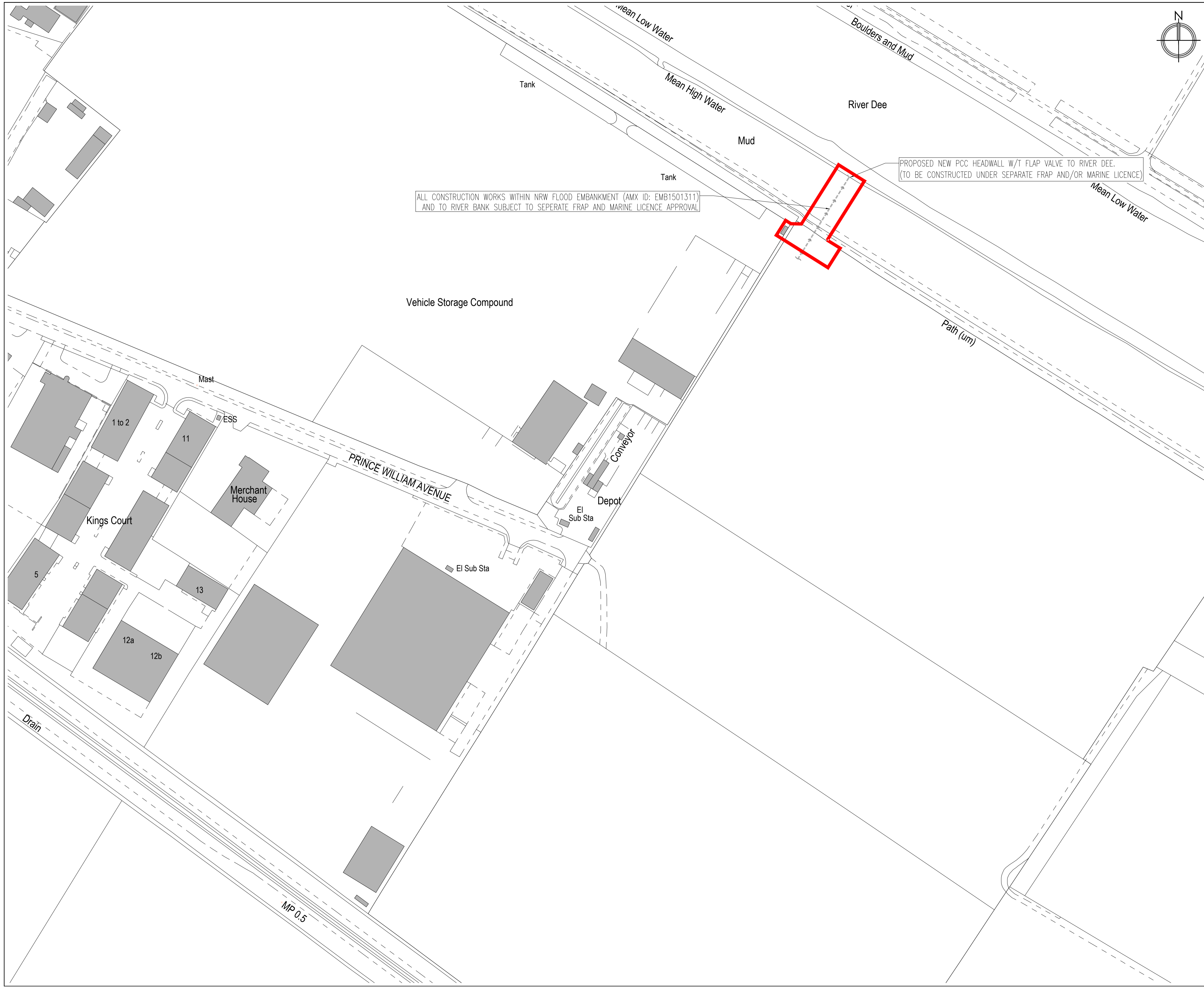

ALL CONSTRUCTION WORKS WITHIN NRW FLOOD EMBANKMENT (AMX ID: EMB1501311) AND TO RIVER BANK SUBJECT TO SEPERATE FRAP AND MARINE LICENCE APPROVAL

PROPOSED NEW PCC HEADWALL W/T FLAP VALVE TO RIVER DEE. (TO BE CONSTRUCTED UNDER SEPERATE FRAP AND/OR MARINE LICENCE)

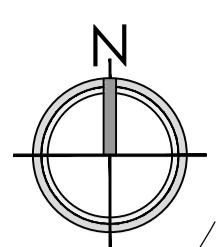

NOTES

- GENERAL**
1. ALL DIMENSIONS ARE IN MILLIMETRES UNLESS NOTED OTHERWISE. ALL LEVELS ARE IN METRES UNLESS NOTED OTHERWISE.
 2. ALL LEVELS RELATE TO ORDNANCE DATUM UNLESS NOTED OTHERWISE.
 3. DO NOT SCALE FROM THIS DRAWING. USE FIGURED DIMENSIONS ONLY.
 4. ANY DISCREPANCIES TO BE REPORTED IMMEDIATELY TO THE ENGINEER.
 5. THIS DRAWING IS TO BE READ IN CONJUNCTION WITH ALL RELEVANT ARCHITECTS, SUBCONTRACTORS AND SPECIALISTS DRAWINGS AND SPECIFICATIONS.
 6. THIS DRAWING IS COPYRIGHT © PROPERTY OF SHEAR DESIGN LIMITED.

- NOTES:**
1. EXISTING LEVELS AND CONTOURS TAKEN FROM TOPOGRAPHICAL SURVEY PROVIDED BY THE CLIENT.
 2. ALL EXISTING LEVELS TO BE CONFIRMED ON SITE PRIOR TO COMMENCEMENT OF WORKS.
 3. REFER TO SITE TOPOGRAPHICAL SURVEY FOR DETAILS OF EXISTING SITE CONDITIONS AND BENCH MARKS.
 4. PRIOR TO COMMENCEMENT OF THE WORKS THE CONTRACTOR SHALL LIAISE WITH ALL RELEVANT AUTHORITIES TO LOCATE, PROTECT AND WHERE NECESSARY DIVERT ALL EXISTING SERVICES AFFECTED BY THE WORKS.
 5. POSITION, ROUTE OF AND IMPACT TO EXISTING SERVICES FOLLOWING THE DEVELOPMENT TO BE CONFIRMED BY CLIENT.
 6. CLIENT / CONTRACTOR TO SEEK PERMISSION FOR ALL WORKS WITHIN PUBLIC LAND OR WITHIN LAND NOT WITHIN THE CLIENTS OWNERSHIP.
 7. ALL WORKS WITHIN AREA OF FLOOD EMBANKMENT AND RIVER BANK SUBJECT TO FRAP AND/OR MARINE LICENCE FROM NRW.

LEGEND

— SITE BOUNDARY

REV	DATE	DESCRIPTION	BY	CHK
AMENDMENTS				



CLIENT:
COPART SANDYCROFT, FLINTSHIRE

PROJECT:
FRAP APPLICATION; SI WORKS ONLY
LOCATION PLAN



7 Ashtree Court - Woodsy Close - Cardiff Gate Business Park - Cardiff - CF23 8RW
Tel: 029 2054 7000 - Fax: 029 2054 7001 - www.shear-design.com - enquiries@shear-design.com

DRAWN	CHECKED	DATE	SCALE
TDJ	DKK	DEC 2024	1:1250 @ A1
SHEAR DESIGN REF: 23009	DRAWING NUMBER: 23009-200	REVISION: --	STATUS: P

- GENERAL
1. ALL DIMENSIONS ARE IN MILLIMETRES UNLESS NOTED OTHERWISE.
 2. ALL LEVELS ARE IN METRES UNLESS NOTED OTHERWISE.
 3. DO NOT SCALE FROM THIS DRAWING. USE DIMENSIONS ONLY.
 4. ANY DISCREPANCIES TO BE REPORTED IMMEDIATELY TO THE ENGINEER.
 5. THIS DRAWING TO BE READ IN CONJUNCTION WITH ALL RELEVANT ARCHITECTS, SUBCONTRACTORS AND SPECIALISTS DRAWINGS AND SPECIFICATIONS.
 6. THIS DRAWING IS COPYRIGHT © PROPERTY OF SHEAR DESIGN LIMITED.

- NOTES:
1. EXISTING LEVELS AND CONTOURS TAKEN FROM TOPOGRAPHICAL SURVEY PROVIDED BY THE CLIENT.
 2. LANDSCAPE ARCHITECTS LAYOUTS BASED ON MOST UP TO DATE WIP DRAWINGS PROVIDED AND ALL ENGINEERING DESIGN AND DETAILS SHOWN ARE THEREFORE SUBJECT TO CHANGE.
 3. ALL EXISTING LEVELS TO BE CONFIRMED ON SITE PRIOR TO COMMENCEMENT OF WORKS.
 4. REFER TO SITE TOPOGRAPHICAL SURVEY FOR DETAILS OF EXISTING SITE CONDITIONS AND BENCH MARKS.
 5. PRIOR TO COMMENCEMENT OF THE WORKS THE CONTRACTOR SHALL UNLIE WITH ALL RELEVANT AUTHORITIES TO LOCATE, PROTECT AND WHERE NECESSARY DIVERT ALL EXISTING SERVICES AFFECTED BY THE WORKS.
 6. POSITION, ROUTE OF AND IMPACT TO EXISTING SERVICES FOLLOWING THE DEVELOPMENT TO BE CONFIRMED BY CLIENT.
 7. CLIENT / CONTRACTOR TO SEEK PERMISSION FOR ALL WORKS WITHIN PUBLIC LAND OR WITHIN LAND NOT WITHIN THE CLIENTS OWNERSHIP.
 8. SITE STRIP 450mm WITH 450mm MINIMUM DEPTH OF CONSTRUCTION. (BASED ON GROUND INVESTIGATION INFORMATION PROVIDED AND TO VARY BETWEEN 200mm & 500mm ACROSS THE SITE. REFER TO DRG 23009-100 EXISTING LEVELS & CONTOURS)
 9. REFER TO DRG 23009-511, PROPOSED DRAINAGE CONSTRUCTION DETAILS FOR TYPICAL FILL CONSTRUCTION DETAILS.
 - 9.1. SITE CBR ASSUMED TO BE >1% (TYP)
 - 9.2. CONTRACTOR TO ALLOW FOR CBR TESTING PRIOR TO COMMENCEMENT OF WORKS ON SITE AND/OR ORDERING OF MATERIALS. CAPPING TO BE ADJUSTED ACCORDINGLY.
 - 9.3. ALL SOFT-SPOTS TO BE SUITABLY INFILLED AND REMOVED WHERE REQUIRED.
 - 9.4. SHOULD CBR RESULTS BE LOWER THAN 1%, FURTHER GROUND REINFORCEMENT AND / OR REVERSE CONSTRUCTION MAKE UPS WILL BE REQUIRED (TO BE COMPLETED BY CONTRACTOR WITHIN DETAILED DESIGN).
 10. WHERE DEPTH FROM FORMATION, FOLLOWING SITE STRIP, TO PROPOSED SURFACE LEVEL EXCEEDS 450mm, SITE WON AND/OR TYPE 2C MATERIAL TO BE USED AND COMPACTED AS SPECIFIED IN COMPACTION REQUIREMENTS OF CLAUSE 612, TABLE 6/4 U.L.O.
 11. SUB BASE TO BE LAID IN 2 SEPARATE LAYERS WITH TYPICAL COMPACTION SPECIFICATION AS FOLLOWS:
 - 11.1. VIBRATE EACH LAYER TO COMPACT
 - 11.2. FINAL PASS TAKEN WITH NO VIBRATION
 - 11.3. COMPACTION SHOULD CONTINUE UNTIL 97% OF THE COMPACTED BULK DENSITY ACHIEVABLE UNDER LABORATORY CONDITIONS HAS BEEN REACHED- MEASURED WITH A NUCLEAR DENSITY GAUGE.
 12. ALL COMPACTION TO COMPLY AND BE CARRIED OUT IN ACCORDANCE WITH CLAUSE 612, TABLE 6/4

- DRAINAGE NOTES
1. THE PROPOSED DRAINAGE LAYOUT RELIES UPON ALL CONSTRAINTS, DESIGN PARAMETERS AND PRINCIPLES SHOWN WITHIN FCA PREPARED BY WEETWOOD SERVICES LTD.
 2. EXISTING SEWERS TO BE REUSED SHALL BE CCTV SURVEYED AND REPAIRED IN ACCORDANCE WITH THE SEWER REHABILITATION MANUAL AND TO THE SATISFACTION OF THE DRAINAGE STATUTORY UNDERWRITER. ALL EXCAVATIONS SHALL BE KEPT FREE OF STANDING WATER.
 3. MAIN SEWER AND COLLECTOR DRAIN RUNS SHOWN. CONTRACTOR'S DESIGN TEAM TO REVIEW ALL POSITIONS, SIZES AND DETAIL DURING DETAILED DESIGN.
 4. THE CONTRACTOR SHALL ENSURE THE STABILITY OF ALL EXCAVATIONS IS MAINTAINED AT ALL TIMES.
 5. SHALLOW SEWERS (<1.2m COVER TO PIPE SOFFIT) AND SEWERS ADJACENT TO EXISTING AND PROPOSED TREES / DENSE VEGETATION WILL REQUIRE CONCRETE PROTECTION IN ACCORDANCE WITH THE DETAILS, CLASS 2 BEDDING.
 6. ELSEWHERE PIPEWORK IS TO RECEIVE CLASS 3 BEDDING AND SURROUNDING BEDDING AND SURROUNDING MATERIAL SHALL MEET THE REQUIREMENTS OF THE PIPE MANUFACTURERS RECOMMENDATIONS.
 7. PIPEWORK CONNECTIONS TO MANHOLES ARE TO BE LAID SOFFIT TO SOFFIT.
 8. VITRIFIED CLAY PIPES AND FITTINGS FOR GRAVITY SEWERS SHALL HAVE FLEXIBLE MECHANICAL JOINTS. PIPES SHALL COMPLY WITH THE RELEVANT REQUIREMENTS OF BS EN 295-1 AND BS 65 (SURFACE WATER PIPES ONLY).
 9. THERMOPLASTIC STRUCTURED WALL SEWER PIPE SHALL COMPLY WITH THE RELEVANT PROVISIONS OF BS EN 13476-1 AND WS 4-35-01 AND BS EN 13476-2 OR BS EN 13476-3. PIPES SHALL BE BS K15/ITEMARKED OR HAVE THE EQUIVALENT THIRD PARTY CERTIFICATION E.G. OSMA DRAIN FOR PIPES < DN160mm OR OSMa ULTRABOND FOR PIPES > DN160mm
 10. PIPES LESS THAN OR EQUAL TO 500mm IN DIAMETER SHALL HAVE NOMINAL SHORT-TERM RING STIFFNESS NOT LESS THAN 8 kN PER m² (S8) OR BE SUBJECT TO A QUALITY SYSTEM FOR STORAGE AND ERECTION.
 11. FOR PIPES GREATER THAN 500mm IN DIAMETER, A NOMINAL SHORT-TERM RING STIFFNESS OF 2 kN PER m² (S2) IS ACCEPTABLE, SUBJECT TO MANUFACTURER'S STRUCTURAL DESIGN LOAD CALCULATIONS IN ACCORDANCE WITH BS 8005:2019 WHICH SHALL BE PROVIDED TO SUPPORT THIS.
 12. ALL PIPE WORK EQUAL OR GREATER TO BE PRECAST CONCRETE.
 13. ABANDONED SEWERS SHALL BE REMOVED OR GROUTED OVER THEIR FULL LENGTH AND MANHOLES SHALL BE BROKEN OUT AND BACK FILLED WITH LEAN MIX CONCRETE TO 1.5m BELOW GROUND LEVEL.
 14. PIPE TO PIPE CONNECTIONS INCLUDING GULLY CONNECTIONS TO BE PREFABRICATED JOINTS.
 15. ALL BRANCH CONNECTION IN MANHOLES TO BE SWEEP IN THE MAIN FLOW DIRECTION.
 16. CLIENT / CONTRACTOR TO SEEK PERMISSION FOR ALL WORKS WITHIN PUBLIC LAND OR WITHIN LAND NOT WITHIN THE CLIENTS OWNERSHIP.

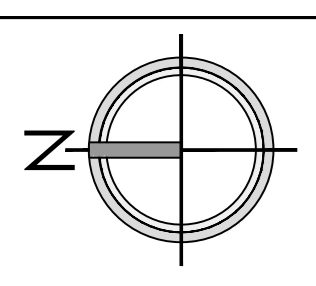

150mm at HL (OVERFLOW)
L > WATER LEVEL DURING 1in100yr + 400CC
(TO BE ARRANGED BY OTHERS)

WORKS WITHIN NEW FLOOD EMBANKMENT (MAX ID: EM1501011) AND TO RIVER BANK SUBJECT TO FRAP AND MARINE LICENCE APPROVAL (TO BE ARRANGED BY OTHERS)

DOE TO SITE'S SSSI & SAC DESIGNATION, ECOLOGICAL AND ENVIRONMENTAL CONDITIONS TO BE REVIEWED BY OTHERS WITH REQUIREMENTS RELATED TO ENGINEER AND WIDER DESIGN TEAM DETAILED DESIGN AND CONSTRUCTION METHODS TO CONSIDER ALL FINDINGS AND REQUIREMENTS.

PROPOSED NEW PCC HEADWALL W/ FLAP VALVE TO RIVER DEEL (ALTHON SFARO O.S.A.) HEADWALL TO FEATURE OSSIPATION / CASCADE BLOCKS WITH REND MATRESS TO RIVER BANK EDGE. DETAILED DESIGN OF ATTENUATION TO CONSIDER POSSIBLE TIDAL LOCK SCENARIOS SHOULD THE OUTFALL BE SUBMERGED.

SWCP19 CL 5.350m
L 1.78m
W/ INTERNAL PENSTOCK VALVE W/ INTERNAL PENSTOCK VALVE

SWCP3 CL 5.350m
L 3.851m

SWCP4 CL 5.117m
L 2.590m

SWCP6 CL 4.822m
L 2.949m

SWCP8 CL 4.822m
L 3.696m

SWCP11 CL 4.816m
L 3.691m

SWCP12 CL 4.816m
L 3.640m

SWCP15 CL 4.874m
L 3.674m

SWCP16 w/1 ORIFICE PLATE ON OUTLET CL 4.841m IL 2.949m

SWCP17 w/1 VORTEX FLOW CONTROL CL 5.052m IL 2.122m

SWCP18 w/1 VORTEX FLOW CONTROL CL 4.803m IL 1.364m

SWCP14 w/1 VORTEX FLOW CONTROL CL 4.284m IL 1.524m

SWCP10 CL 5.032m IL 1.863m

SWCP9 CL 4.966m IL 2.768m

SWCP5 CL 5.023m IL 3.886m

SWCP2 CL 5.149m IL 3.435m

SWCP1 CL 5.230m IL 4.030m

150mm at HL (OVERFLOW)
L > WATER LEVEL DURING 1in100yr + 400CC
(TO BE ARRANGED BY OTHERS)

WORKS WITHIN NEW FLOOD EMBANKMENT (MAX ID: EM1501011) AND TO RIVER BANK SUBJECT TO FRAP AND MARINE LICENCE APPROVAL (TO BE ARRANGED BY OTHERS)

DOE TO SITE'S SSSI & SAC DESIGNATION, ECOLOGICAL AND ENVIRONMENTAL CONDITIONS TO BE REVIEWED BY OTHERS WITH REQUIREMENTS RELATED TO ENGINEER AND WIDER DESIGN TEAM DETAILED DESIGN AND CONSTRUCTION METHODS TO CONSIDER ALL FINDINGS AND REQUIREMENTS.

PROPOSED NEW PCC HEADWALL W/ FLAP VALVE TO RIVER DEEL (ALTHON SFARO O.S.A.) HEADWALL TO FEATURE OSSIPATION / CASCADE BLOCKS WITH REND MATRESS TO RIVER BANK EDGE. DETAILED DESIGN OF ATTENUATION TO CONSIDER POSSIBLE TIDAL LOCK SCENARIOS SHOULD THE OUTFALL BE SUBMERGED.

SWCP19 CL 5.350m
L 1.78m
W/ INTERNAL PENSTOCK VALVE W/ INTERNAL PENSTOCK VALVE

SWCP3 CL 5.350m
L 3.851m

SWCP4 CL 5.117m
L 2.590m

SWCP6 CL 4.822m
L 2.949m

SWCP8 CL 4.822m
L 3.696m

SWCP11 CL 4.816m
L 3.691m

SWCP12 CL 4.816m
L 3.640m

SWCP15 CL 4.874m
L 3.674m

SWCP16 w/1 ORIFICE PLATE ON OUTLET CL 4.841m IL 2.949m

SWCP17 w/1 VORTEX FLOW CONTROL CL 5.052m IL 2.122m

SWCP18 w/1 VORTEX FLOW CONTROL CL 4.803m IL 1.364m

SWCP14 w/1 VORTEX FLOW CONTROL CL 4.284m IL 1.524m

SWCP10 CL 5.032m IL 1.863m

SWCP9 CL 4.966m IL 2.768m

SWCP5 CL 5.023m IL 3.886m

SWCP2 CL 5.149m IL 3.435m

SWCP1 CL 5.230m IL 4.030m

150mm at HL (OVERFLOW)
L > WATER LEVEL DURING 1in100yr + 400CC
(TO BE ARRANGED BY OTHERS)

WORKS WITHIN NEW FLOOD EMBANKMENT (MAX ID: EM1501011) AND TO RIVER BANK SUBJECT TO FRAP AND MARINE LICENCE APPROVAL (TO BE ARRANGED BY OTHERS)

DOE TO SITE'S SSSI & SAC DESIGNATION, ECOLOGICAL AND ENVIRONMENTAL CONDITIONS TO BE REVIEWED BY OTHERS WITH REQUIREMENTS RELATED TO ENGINEER AND WIDER DESIGN TEAM DETAILED DESIGN AND CONSTRUCTION METHODS TO CONSIDER ALL FINDINGS AND REQUIREMENTS.

PROPOSED NEW PCC HEADWALL W/ FLAP VALVE TO RIVER DEEL (ALTHON SFARO O.S.A.) HEADWALL TO FEATURE OSSIPATION / CASCADE BLOCKS WITH REND MATRESS TO RIVER BANK EDGE. DETAILED DESIGN OF ATTENUATION TO CONSIDER POSSIBLE TIDAL LOCK SCENARIOS SHOULD THE OUTFALL BE SUBMERGED.

SWCP19 CL 5.350m
L 1.78m
W/ INTERNAL PENSTOCK VALVE W/ INTERNAL PENSTOCK VALVE

SWCP3 CL 5.350m
L 3.851m

SWCP4 CL 5.117m
L 2.590m

SWCP6 CL 4.822m
L 2.949m

SWCP8 CL 4.822m
L 3.696m

SWCP11 CL 4.816m
L 3.691m

SWCP12 CL 4.816m
L 3.640m

SWCP15 CL 4.874m
L 3.674m

SWCP16 w/1 ORIFICE PLATE ON OUTLET CL 4.841m IL 2.949m

SWCP17 w/1 VORTEX FLOW CONTROL CL 5.052m IL 2.122m

SWCP18 w/1 VORTEX FLOW CONTROL CL 4.803m IL 1.364m

SWCP14 w/1 VORTEX FLOW CONTROL CL 4.284m IL 1.524m

SWCP10 CL 5.032m IL 1.863m

SWCP9 CL 4.966m IL 2.768m

SWCP5 CL 5.023m IL 3.886m

SWCP2 CL 5.149m IL 3.435m

SWCP1 CL 5.230m IL 4.030m

150mm at HL (OVERFLOW)
L > WATER LEVEL DURING 1in100yr + 400CC
(TO BE ARRANGED BY OTHERS)

WORKS WITHIN NEW FLOOD EMBANKMENT (MAX ID: EM1501011) AND TO RIVER BANK SUBJECT TO FRAP AND MARINE LICENCE APPROVAL (TO BE ARRANGED BY OTHERS)

DOE TO SITE'S SSSI & SAC DESIGNATION, ECOLOGICAL AND ENVIRONMENTAL CONDITIONS TO BE REVIEWED BY OTHERS WITH REQUIREMENTS RELATED TO ENGINEER AND WIDER DESIGN TEAM DETAILED DESIGN AND CONSTRUCTION METHODS TO CONSIDER ALL FINDINGS AND REQUIREMENTS.

PROPOSED NEW PCC HEADWALL W/ FLAP VALVE TO RIVER DEEL (ALTHON SFARO O.S.A.) HEADWALL TO FEATURE OSSIPATION / CASCADE BLOCKS WITH REND MATRESS TO RIVER BANK EDGE. DETAILED DESIGN OF ATTENUATION TO CONSIDER POSSIBLE TIDAL LOCK SCENARIOS SHOULD THE OUTFALL BE SUBMERGED.

SWCP19 CL 5.350m
L 1.78m
W/ INTERNAL PENSTOCK VALVE W/ INTERNAL PENSTOCK VALVE

SWCP3 CL 5.350m
L 3.851m

SWCP4 CL 5.117m
L 2.590m

SWCP6 CL 4.822m
L 2.949m

SWCP8 CL 4.822m
L 3.696m

SWCP11 CL 4.816m
L 3.691m

SWCP12 CL 4.816m
L 3.640m

SWCP15 CL 4.874m
L 3.674m

SWCP16 w/1 ORIFICE PLATE ON OUTLET CL 4.841m IL 2.949m

SWCP17 w/1 VORTEX FLOW CONTROL CL 5.052m IL 2.122m

SWCP18 w/1 VORTEX FLOW CONTROL CL 4.803m IL 1.364m

SWCP14 w/1 VORTEX FLOW CONTROL CL 4.284m IL 1.524m

SWCP10 CL 5.032m IL 1.863m

SWCP9 CL 4.966m IL 2.768m

SWCP5 CL 5.023m IL 3.886m

SWCP2 CL 5.149m IL 3.435m

SWCP1 CL 5.230m IL 4.030m

150mm at HL (OVERFLOW)
L > WATER LEVEL DURING 1in100yr + 400CC
(TO BE ARRANGED BY OTHERS)

WORKS WITHIN NEW FLOOD EMBANKMENT (MAX ID: EM1501011) AND TO RIVER BANK SUBJECT TO FRAP AND MARINE LICENCE APPROVAL (TO BE ARRANGED BY OTHERS)

DOE TO SITE'S SSSI & SAC DESIGNATION, ECOLOGICAL AND ENVIRONMENTAL CONDITIONS TO BE REVIEWED BY OTHERS WITH REQUIREMENTS RELATED TO ENGINEER AND WIDER DESIGN TEAM DETAILED DESIGN AND CONSTRUCTION METHODS TO CONSIDER ALL FINDINGS AND REQUIREMENTS.

PROPOSED NEW PCC HEADWALL W/ FLAP VALVE TO RIVER DEEL (ALTHON SFARO O.S.A.) HEADWALL TO FEATURE OSSIPATION / CASCADE BLOCKS WITH REND MATRESS TO RIVER BANK EDGE. DETAILED DESIGN OF ATTENUATION TO CONSIDER POSSIBLE TIDAL LOCK SCENARIOS SHOULD THE OUTFALL BE SUBMERGED.

SWCP19 CL 5.350m
L 1.78m
W/ INTERNAL PENSTOCK VALVE W/ INTERNAL PENSTOCK VALVE

SWCP3 CL 5.350m
L 3.851m

SWCP4 CL 5.117m
L 2.590m

SWCP6 CL 4.822m
L 2.949m

SWCP8 CL 4.822m
L 3.696m

SWCP11 CL 4.816m
L 3.691m

SWCP12 CL 4.816m
L 3.640m

SWCP15 CL 4.874m
L 3.674m

SWCP16 w/1 ORIFICE PLATE ON OUTLET CL 4.841m IL 2.949m

SWCP17 w/1 VORTEX FLOW CONTROL CL 5.052m IL 2.122m

SWCP18 w/1 VORTEX FLOW CONTROL CL 4.803m IL 1.364m

SWCP14 w/1 VORTEX FLOW CONTROL CL 4.284m IL 1.524m

SWCP10 CL 5.032m IL 1.863m

SWCP9 CL 4.966m IL 2.768m

SWCP5 CL 5.023m IL 3.886m

SWCP2 CL 5.149m IL 3.435m

SWCP1 CL 5.230m IL 4.030m

ALL INFORMATION AND DETAILS ARE SHOWN INDICATIVELY AND ARE TO BE USED FOR INITIAL TENDER & PLANNING PURPOSES ONLY.

ALL LEVELS, DETAILS & DRAINAGE SHOWN SUBJECT TO REVISION OR CHANGE WITHIN DETAILED DESIGN

- LEGEND
- SITE BOUNDARY (TAKEN FROM ARCHITECTURAL LAYOUT PROVIDED)
 - PROPOSED INTERNAL FENCE LINE
 - PROPOSED MAJOR CONTOUR AT 500mm INTERVALS
 - PROPOSED MINOR CONTOUR AT 100mm INTERVALS
 - UNCHANGED/EXISTING MAJOR CONTOUR AT 500mm INTERVALS
 - UNCHANGED/EXISTING MINOR CONTOUR AT 100mm INTERVALS
 - PROPOSED CARRIER DRAINAGE
 - PROPOSED 150mm PERFORATED HOPE COLLECTOR PIPES
 - PROPOSED RISING MAIN

VORTEX FLOW CONTROL (HYDROBRAKE O.S.A.) LIMITING DISCHARGE FROM THE EXTENSION SITE TO 73.0 l/s DURING ALL STORM EVENTS UP TO AND INCLUDING THE 1in100yr + 400CC CRITICAL STORM.

PUMPING STATION Ø 73.0 l/s CL 4.802m L 1.78m PUMP & RISING MAIN TO MANUFACTURER'S DESIGN AND SPECIFICATION.

EXCESS FLOW 300mm ATTENUATION STORAGE BASED ON INTENDED MAX 1.0m WATER DEPTH W/1 150mm FREEBOARD. (LEVEL DURING CRITICAL 1in100yr+400CC 4.285m AOD, APPROX. 500mm DEPTH)

INLET/OUTLET TO EXCESS FLOW BASIN L 3.722m

PO3	17.06.24	GENERAL AMENDMENTS	TDU/AM	DKK
PO2	08.02.24	ADDITIONAL NOTES ADDED AND LINE TYPES UPDATED	TDU	DKK
PO1	02.02.24	DRAINAGE LAYOUT & MODEL AMENDED TO REFLECT REVISED SITE DESIGN	TDU	DKK
REV	DATE	DESCRIPTION	BY	CHK

CLIENT: **Gopart**

PROJECT: COPART, SANDY CROFT FLINTSHIRE

FILE: PROPOSED DRAINAGE LAYOUT

SHEAR design
Consulting Civil and Structural Engineers

7 Ashbee Court - Woodley Close - Cardiff Gate Business Park - Cardiff - CF23 8RW
Tel: 029 2054 7000 - Fax: 029 2054 7001 - www.shear-design.com - enquiries@shear-design.com

DATE: FEB 2024 SCALE: 1:750 @ A0

DRAWING NUMBER: 23009-500

REVISION: P03

DESIGNER: P

NOTES



GENERAL

1. ALL DIMENSIONS ARE IN MILLIMETRES UNLESS NOTED OTHERWISE.
2. ALL LEVELS RELATE TO ORDNANCE DATUM UNLESS NOTED OTHERWISE.
3. DO NOT SCALE FROM THIS DRAWING. USE FIGURED DIMENSIONS ONLY.
4. ANY DISCREPANCIES TO BE REPORTED IMMEDIATELY TO THE ENGINEER.
5. THIS DRAWING IS TO BE READ IN CONJUNCTION WITH ALL RELEVANT ARCHITECTS, SUBCONTRACTORS AND SPECIALISTS DRAWINGS AND SPECIFICATIONS.
6. THIS DRAWING IS COPYRIGHT © PROPERTY OF SHEAR DESIGN LIMITED.

NOTES:

1. EXISTING LEVELS AND CONTOURS TAKEN FROM TOPOGRAPHICAL SURVEY PROVIDED BY THE CLIENT.
2. ALL EXISTING LEVELS TO BE CONFIRMED ON SITE PRIOR TO COMMENCEMENT OF WORKS.
3. REFER TO SITE TOPOGRAPHICAL SURVEY FOR DETAILS OF EXISTING SITE CONDITIONS AND BENCH MARKS.
4. PRIOR TO COMMENCEMENT OF THE WORKS THE CONTRACTOR SHALL LIAISE WITH ALL RELEVANT AUTHORITIES TO LOCATE, PROTECT AND WHERE NECESSARY DIVERT ALL EXISTING SERVICES AFFECTED BY THE WORKS. POSITION, ROUTE OF AND IMPACT TO EXISTING SERVICES FOLLOWING THE DEVELOPMENT TO BE CONFIRMED BY CLIENT.
5. CLIENT / CONTRACTOR TO SEEK PERMISSION FOR ALL WORKS WITHIN PUBLIC LAND OR WITHIN LAND NOT WITHIN THE CLIENTS OWNERSHIP.
6. ALL WORKS WITHIN AREA OF FLOOD EMBANKMENT AND RIVER BANK SUBJECT TO FRAP AND/OR MARINE LICENCE FROM NRW.
7. LOCATION AND QUANTITY OF BOREHOLE TESTS SUBJECT TO ON-SITE CONDITIONS AND GEOTECHNICAL ENGINEERS' COMMENTS
- 8.1. REFER TO GEOTECHNICAL ENGINEERS' RAMS
9. THIS DRAWING IS TO BE READ IN CONJUNCTION WITH SHEAR DESIGN DRG 23009-201 SITE LAYOUT

LEGEND

-  EXISTING GROUND LEVEL (UNCHANGED BY SI WORKS)
-  PROPOSED BOREHOLE LOCATION (SUBJECT TO SITE CONDITIONS)

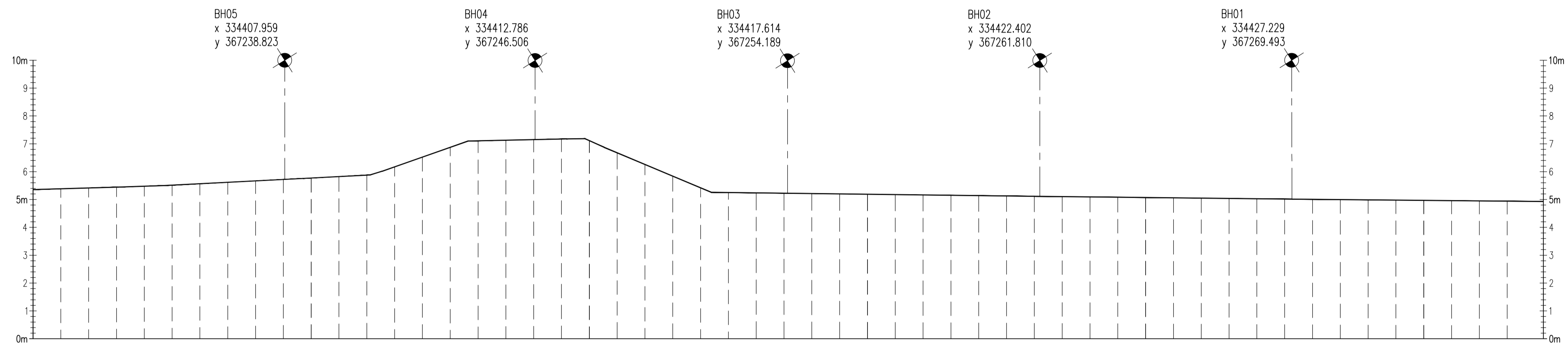

EXISTING LEVELS	5.357	5.387	5.416	5.446	5.477	5.515	5.567	5.618	5.669	5.720	5.772	5.823	5.874	6.173	6.524	6.874	7.108	7.130	7.152	7.174	7.115	6.679	6.259	5.838	5.418	5.251	5.239	5.226	5.214	5.202	5.189	5.177	5.165	5.152	5.140	5.128	5.115	5.105	5.095	5.085	5.074	5.062	5.051	5.040	5.028	5.017	5.007	4.998	4.989	4.979	4.970	4.961	4.952	4.942	4.933
CHAINAGE	00.000	01.000	02.000	03.000	04.000	05.000	06.000	07.000	08.000	09.000	10.000	11.000	12.000	13.000	14.000	15.000	16.000	17.000	18.000	19.000	20.000	21.000	22.000	23.000	24.000	25.000	26.000	27.000	28.000	29.000	30.000	31.000	32.000	33.000	34.000	35.000	36.000	37.000	38.000	39.000	40.000	41.000	42.000	43.000	44.000	45.000	46.000	47.000	48.000	49.000	50.000	51.000	52.000	53.000	54.000

EXISTING/PROPOSED SECTION THROUGH FLOOD EMBANKMENT
(SCALE: H 1:100, V 1:100 @ A1 DATUM: 0.000)

REV	DATE	DESCRIPTION	BY	CHK
-----	------	-------------	----	-----

CLIENT: 

PROJECT: COPART SANDYCROFT, FLINTSHIRE

TITLE: FRAP APPLICATION; SI WORKS ONLY
SITE LONGSECTION



Consulting Civil and Structural Engineers
7 Ashtree Court - Woody Close - Cardiff Gate Business Park - Cardiff - CF23 8RW
Tel: 029 2054 7000 - Fax: 029 2054 7001 - www.shear-design.com - enquiries@shear-design.com

DRAWN: TDJ	CHECKED: DKK	DATE: DEC 2024	SCALE: 1:100 @ A1
SHEAR DESIGN REF: 23009	DRAWING NUMBER: 23009-202	REVISION: --	STATUS: P

HEALTH AND SAFETY

METHOD STATEMENT

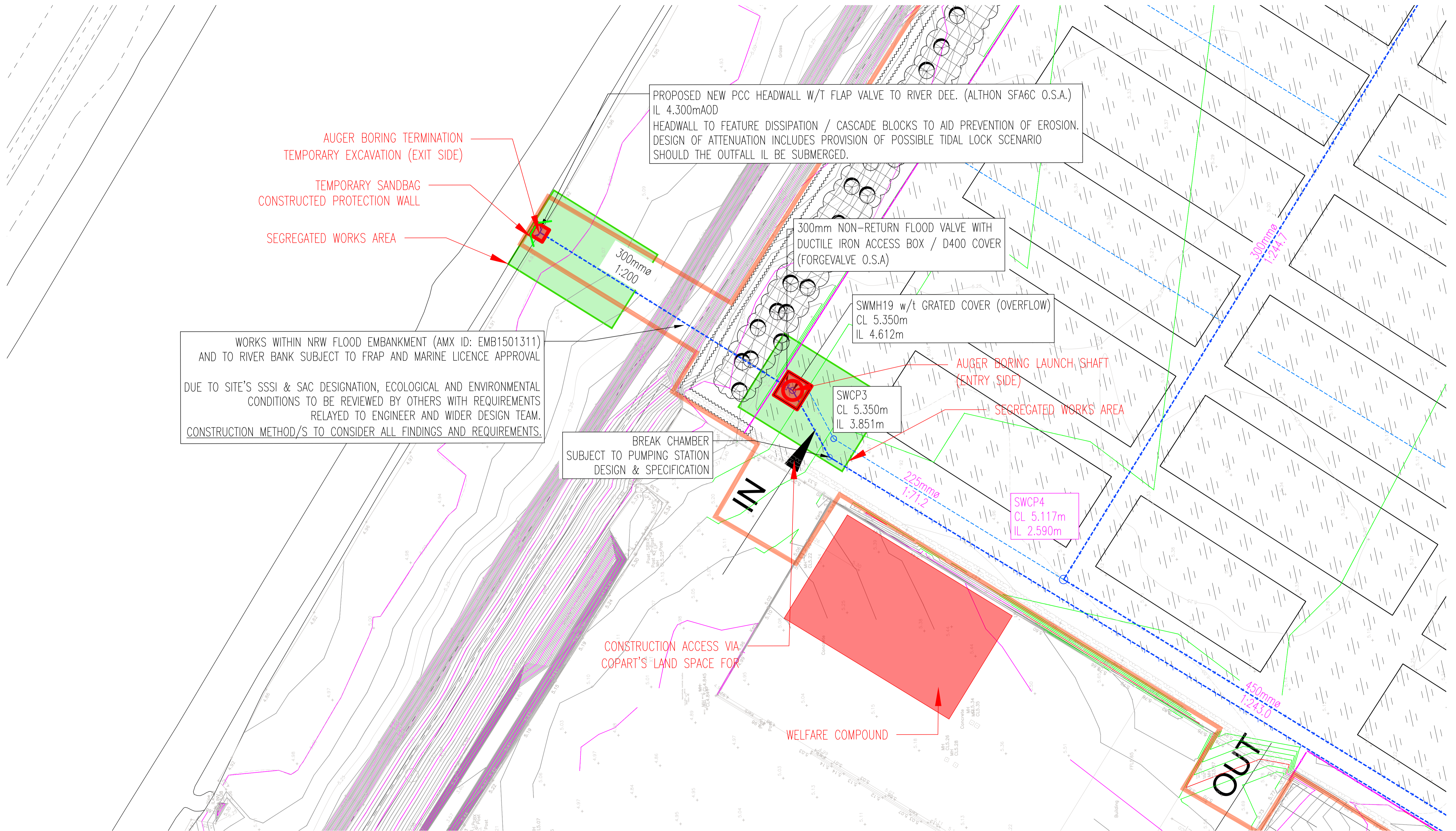
Appendix 03	MYCO Works Layout Plan
-------------	------------------------



LAND EAST OF COPART, SANDYCROFT, FLINTSHIRE
Layout Plan- Proposed Drainage Outfall Pipe Construction Beneath Existing Flood Bund
 FOR REVIEW

HEALTH AND SAFETY

METHOD STATEMENT

Appendix 04	RAMS Briefing Register
-------------	------------------------

