

Intended for  
**AB InBev UK Limited**

Date  
**September 2019**

Project Number  
**1700003382\_ERA**

# **AB INBEV UK LIMITED** **ENVIRONMENTAL RISK** **ASSESSMENT**

# AB INBEV UK LIMITED ENVIRONMENTAL RISK ASSESSMENT

Project No. **1700002282**  
Issue No. **01**  
Date **30/09/2019**  
Made by **Lucy Cleverley/ Karen Hardy**  
Checked by **Lucy Cleverley**  
Approved by **Greg Roberts**

Made by:		
Checked/Approved by:		

*This report has been prepared by Ramboll UK Limited with all reasonable skill, care and diligence, and taking account of the Services and the Terms agreed between Ramboll UK Limited and the Client. This report is confidential to the Client, and Ramboll UK Limited accepts no responsibility whatsoever to third parties to whom this report, or any part thereof, is made known, unless formally agreed by Ramboll UK Limited beforehand. Any such party relies upon the report at their own risk. Ramboll UK Limited disclaims any responsibility to the Client and others in respect of any matters outside the agreed scope of the Services.*

## Version Control Log

Revision	Date	Made by	Checked by	Approved by	Description
1	30/09/2019	LC/ KH	LC	GR	First issue to client

## CONTENTS

<b>INTRODUCTION</b>	<b>1</b>
<b>1. IDENTIFICATION OF ENVIRONMENTAL RISKS</b>	<b>2</b>
1.1 Source-Pathway-Receptor Concept	2
1.2 Environmental Risks	2
<b>2. IDENTIFICATION OF RECEPTORS</b>	<b>5</b>
<b>3. POTENTIAL POLLUTION PATHWAYS</b>	<b>7</b>
3.1 Identification of Possible Pathways from the Sources of the Risks to Receptors	7
<b>4. RISK ASSESSMENT METHODOLOGY</b>	<b>9</b>
4.1 Assessing Likelihood and Consequence	9
4.2 Assessment of Risk	9
<b>5. RISK ASSESSMENT</b>	<b>10</b>
5.1 Controlled Discharge to Surface Water	10
5.2 Odour	12
5.3 Noise	13
5.4 Accidents	14
5.5 Fugitive Emissions	17
5.6 Controlled Releases to Air	19
5.7 Global Warming Potential	20
5.8 Installation Waste	21
<b>6. ERA CONCLUSION</b>	<b>23</b>

## APPENDICES

### Appendix 1

Exova Air Modelling Report

### Appendix 2

Flue Ace Air Quality Assessment

## INTRODUCTION

Ramboll Environment and Health UK Limited (Ramboll) was commissioned by AB InBev UK Limited ('AB InBev' or the 'Client') to prepare a Site Condition Report (SCR) for its manufacturing facility located at The Brewery, Wilcrick, Magor, Caldicot, Monmouthshire, NP26 3RA (the 'Facility' or the 'site'). The SCR shall support AB InBev's application for a variation to their existing Environmental Permit (EP) (BX7282IS).

The SCR (and application for a variation to the EP) requires an Environmental Risk Assessment (ERA) to be carried out based on Natural Resources Wales' EPR H1 Guidance. The objective of the ERA is to identify the substances used and produced that could pollute the soil or groundwater if there was an accident, or if measures to protect land fail.

In accordance with the aforementioned guidance, this ERA is structured as follows:

1. Identification and consideration of risks for the Facility and sources of the risks.
2. Identification of receptors (people, animals, property and anything else that could be affected by the hazard) at risk from the Facility.
3. Identification of possible pathways from the sources of the risks to receptors.
4. Assessment of the risks relevant to the specific activities carried out at the site and consideration of which risks can be screened out as negligible.
5. Description of measures to control identified risks.

# 1. IDENTIFICATION OF ENVIRONMENTAL RISKS

## 1.1 Source-Pathway-Receptor Concept

In order for pollution to have an impact on the environment, a pollution linkage must be present which relies on the Source-Pathway-Receptor concept, where all three factors must be present and linked for a potential risk to exist.

A "pollution linkage" requires the following:

- i) A "source" is a substance which is in, on or under the land and which has the potential to cause significant harm to a relevant receptor, or to cause significant pollution of controlled waters;
- ii) A "receptor" is something that could be adversely affected by a contaminant, for example a person, an organism, an ecosystem, property, or controlled waters; and
- iii) A "pathway" is a route by which a receptor is or might be affected by a contaminant.

Identification of the source, pathway and receptor enables management interventions to be made to manage the environmental risks and avoid pollution reaching the receptor.

In this section the potential sources (environmental risks) of pollution at the Facility are identified and screened for their significance, and the potential pathways and receptors are identified.

## 1.2 Environmental Risks

The Operator is required to identify the environmental risks (sources of potential contamination) which could occur during the operation of the Facility, including any risks which may arise from accidents. The EA online guidance<sup>1</sup> stipulates that the Operator must consider the following potential risks:

- any discharge (e.g. sewage or trade effluent to surface water or groundwater);
- accidents;
- odour;
- noise and vibration;
- uncontrolled and unintended ('fugitive') emissions (for which risks include dust, litter, pests; and pollutants that shouldn't be in the discharge); and
- visible emissions (e.g. smoke or visible plumes).

In considering the risk, the Operator can determine that a potential risk is not considered to be significant in terms of its potential impact on the environment; however, a justification must be provided for any risk which is 'screened out'.

Based on the guidance summarised above the potential environmental risks at the Facility have been identified and have been determined either applicable or not applicable based on the potential environmental impact arising from the risk. A summary of these risks is presented in the table below which also provides justifications where risks are considered to be insignificant. The risks which have been identified as significant have been included in the risk assessment in Section 5 of this report.

---

<sup>1</sup> <https://www.gov.uk/guidance/risk-assessments-for-your-environmental-permit#risks-from-your-site>

**Table 1.1: Screening of Environmental Risks**

<b>Environmental Risk</b>	<b>Applicability</b>	<b>Justification</b>
Controlled discharges to surface waters	Applicable	Under its Environmental Permit (BX7282IS), the Facility has three permitted discharges to surface water: discharge of treated effluent from the ETP into the Severn Estuary; disposal of surface water at the main brewery site to the Waundeilad Reen; and disposal of surface water at the effluent treatment plant site to the Mill Reen.
Controlled discharges to Groundwater	Not Applicable	There are no controlled discharges to groundwater from the Facility. This risk has not been considered for further assessment.
Accidents	Applicable	<p>Plant or Equipment Failure: Large quantities of equipment are in-use across the Facility. The failure of plant or equipment may result in an incident occurring which could potentially impact on the environment.</p> <p>Materials Handling: Raw materials and wastes are stored on both the main site and the ETP site in bulk and are transported across the Facility via pipework and in IBCs on fork lift trucks. There is the potential for accidents (e.g. spills, leaks etc.) to occur during the filling of bulk storage vessels and the movement of materials, which may result in contaminated run-off.</p> <p>Vandalism: The Facility is located in a relatively remote rural area and may be a target for vandalism and theft.</p> <p>Operator Error: Whilst the majority of the processing plant is automated, the potential for operator error cannot be ruled out.</p>
Odour	Applicable	Emissions from the Installation have the potential to be odorous, particularly the brewing process and operations at the off-site effluent treatment plant. In addition, odours may be produced at the on-site waste water treatment plant and from the storage of waste at the recycling area of the main brewery site.
Noise & Vibration	Applicable	Operations at the Installation have the potential to produce noise, in particularly the movement of Heavy Goods Vehicles making deliveries to and collections from the site. In addition, the use of machinery on-site, the movement of barrels and the boilers have the potential to cause emissions of noise from the site.
Visual Impact	Not Applicable	<p>The Facility is positioned adjacent to the M4 within a predominantly agricultural area with some commercial land uses and sparse residential properties.</p> <p>Visible emissions from the Facility are limited to steam/ water vapour from the evaporative condensers and cooling towers and permitted releases from the boiler stacks.</p> <p>These emissions are not considered to be significant in terms of visual impact. There are no records of complaints regarding the visual impact of emissions at the Facility. Based on this, visual impact has not been considered to be</p>

Environmental Risk	Applicability	Justification
		significant and has not been included for further assessment.
Fugitive Emissions to air and water	Applicable	<p>Surface Water: potential for blocked/ damaged drains or misconnections in the drainage system to result in an uncontrolled release of process wastewater to ground or surface water.</p> <p>Storm water discharges: storm water run-off from the site roofs and yard areas is directed via an integrated wastewater and storm water drainage system to the on-site wastewater treatment plant and then pumped to the off-site ETP. In the event of a flood, process water, diluted by flood water is pumped into the Waundeilad Reen. Although the pH is tested prior to release, there remains the potential for polluted discharges to enter surface water due to failure of the penstock valve or failure of monitoring systems.</p> <p>Dust: The delivery and collection of dry raw materials and wastes give rise to the potential of generation of dust emissions. Whilst dry materials are delivered in internal areas, dry waste materials are currently collected in bulk in a dedicated external area of the site. There is a therefore potential for dust generation in external areas.</p> <p>Litter: Wastes are produced at the Facility which are stored in secure containers at a dedicated, central location of the site, limiting the potential for litter to be windblown. At the off-site ETP, wastes are stored in secure waste skips and are collected by a waste contractor at appropriate intervals.</p>
Controlled releases to air	Applicable	Air emissions comprise combustion products from the Facility's natural gas fired HTHW and steam boilers at the main brewery site and from the CHP plant and flare stack from the anaerobic digestion plant at the effluent treatment plant. In addition, water vapour/ steam from cooling towers and evaporative condensers from brewing vessels, and at various locations around the site.
Global Warming Potential	Applicable	Both direct and indirect greenhouse gas emissions arise from the operation of the Facility. Direct emissions arise from the burning of gas / oil in the on-site boilers and off-site CHP, and operation of the chiller and cooling systems (which use regulated greenhouse gases). Indirect emissions arise from the use of electricity, and water. There are also other indirect impacts from both in the production and supply process.
Facility Waste	Applicable	Hazardous and non-hazardous wastes are produced at the Facility as a result of the production processes, maintenance and administrative functions.

## 2. IDENTIFICATION OF RECEPTORS

A receptor is defined as something that could be adversely affected by a pollutant. Based on visual observations of the Facility and the information relating to its environmental setting (provided in the SCR) Ramboll has identified the receptors within the vicinity of the site. The receptors are depicted on Figure 8 of Appendix 1 of the SCR which shows the Facility boundary and the location of each receptor; a summary of the identified receptors is provided in Table 2.1 below.

**Table 2.1: Summary of Identified Receptors**

<b>Receptor</b>	<b>Location</b>
<p><i>Groundwater:</i> The Brewery site is situated on a Secondary A Aquifer; however, it is not in a Groundwater Source Protection Zone. The Tidal Mud Flats underlying the ETP are classified as Unproductive Strata.</p> <p>There no records of groundwater abstraction wells within 1km of the Brewery or ETP sites.</p>	Across the entirety of the Facility and in the immediate vicinity of the Facility
<p><i>Surface Water:</i></p> <p><u>Brewery Site</u></p> <p>A pond is located on-site, outside the restaurant area and includes several ornamental carp. A surface water pond feature is present outside of the installation boundary, adjacent to the west of the pumping station. Other nearby water features include drainage channels adjacent to a roadway approximately 100m to the south of the site, connecting to a series of drainage reens across Caldicot Level.</p> <p><u>ETP</u></p> <p>The ETP is surrounded by interconnected reens, all of which drain to the Severn Estuary via the Magor Pill.</p> <p>The Facility is permitted to discharge treated process effluent from the ETP to the Severn Estuary, and to discharge uncontaminated surface water from the main brewery site to the Waundeilad Reen and from the ETP site to the Mill Reen.</p> <p>There are no records of surface water abstraction licences recorded within 1km of the Brewery or ETP sites.</p>	On-site and in the immediate vicinity of the Facility.
<p><i>Ground:</i></p> <p><u>Brewery Site</u></p> <p>The site is underlain by Made Ground across the majority of the site to a maximum depth of 1.7m bgl; underlain by gravelly silty sandy clay to a maximum depth of 4.5m bgl; underlain by Sandstone bedrock; or in the far west of the site, Made Ground was found to be underlain by Mercia Mudstone.</p> <p><u>ETP</u></p> <p>The ETP site is underlain by Made Ground to a maximum depth of 1.8m bgl comprising sandy gravelly clay; underlain by clay and gravelly clay to 5m bgl; underlain by Mercia Mudstone.</p>	Across the entirety of the Facility and in the immediate vicinity of the Facility
<p><i>Atmosphere:</i></p> <p><u>Brewery Site</u></p> <p>Air emissions comprise combustion products from the Facility's natural gas fired HTHW and steam boilers. In addition, water vapour/ steam from operations on-site. In addition, water vapour/ steam from cooling towers and evaporative condensers from brewing vessels, and at various locations around the site.</p>	Across the entirety of the Facility and in the immediate vicinity of the Facility

Receptor	Location
<p><u>ETP</u></p> <p>Air emissions at the ETP site comprise combustion products from the CHP plant and from the flare stack from the anaerobic digestion plant.</p>	
<p><i>Designated Ecological Sites:</i></p> <p><u>Brewery Site</u></p> <p>The Gwent Levels Site of Special Scientific Interest (SSSI) is located 358m south of the site, designated due to rich assemblages of invertebrate species. The area also contains a number of nationally rare plant species.</p> <p><u>ETP</u></p> <p>The ETP is located within the Gwent Levels SSSI. The Severn Estuary is located 42m south-east of the site at its closest point and is designated as a SSSI, Special Area of Conservation (SAC), Special Protection Area (SPA) and Ramsar site.</p>	<p>358 m south of the brewery site and 42 m south- east of the ETP.</p>
<p><i>Human Occupation:</i> Facility workers and visitors are present across the internal and external areas of the brewery site, and at operational areas of the ETP site.</p> <p><u>Brewery Site</u></p> <p>There are public footpaths within 36 m south, 136 m south-west and 166 m west of the site. In addition, a hotel is located approximately 161 m north-east, and the M4 approximately 223 m north-east from the site, a police station is present 141 m north-east of the north- eastern site boundary, and the residential area of Magor is situated from 305 m east. A railway line is located approximately 314 m south.</p> <p><u>ETP</u></p> <p>Public footpaths run adjacent to the south-eastern site boundary and within 154 m south-west and 175 m north of the ETP site. The nearest residential properties are situated approximately 530 m north- west. Human receptors are present intermittently at these locations.</p>	<p>On-site and directly adjacent</p>

### 3. POTENTIAL POLLUTION PATHWAYS

#### 3.1 Identification of Possible Pathways from the Sources of the Risks to Receptors

The potential pollution pathways between the sources identified in Section 1 (excluding those which have been screened out) and the receptors identified in Section 2 are summarised in the table below.

**Table 3.1: Potential Pollution Pathways**

<b>Source</b>	<b>Potential Pathway</b>	<b>Receptor</b>
<i>Controlled discharges to surface waters.</i>	Surface water pumped from the brewery site to the Waundeilad Reen. Surface water runoff from the lorry park area to highways surface water drainage. Below ground pipe from the ETP to the Severn Estuary. Surface water at the effluent treatment plant site, discharged to the Mill Reen.	Waundeilad Reen Mill Reen.
<i>Odour:</i> arising from the brewing process; waste materials; effluent at the on-site waste water treatment plant; and operations at the off-site ETP.	Through the air.	<i>Humans including:</i> Facility workers/visitors; workers on adjacent premises; local residents; intermittent presence on pedestrian routes / roadways surrounding the Facility.
<i>Visual emissions:</i> arising from combustion activities; cooling towers and evaporative condensers.	Through the air.	<i>Humans including:</i> Facility workers/visitors; workers on adjacent premises; local residents; intermittent presence on pedestrian routes / roadways surrounding the Facility.
<i>Noise and Vibration:</i> arising from vehicle movements; site operations; process machinery; and ETP.	Transmitted through the air and through ground vibration.	<i>Humans including:</i> Facility workers/visitors; workers on adjacent premises; local residents; intermittent presence on pedestrian routes / roadways surrounding the Facility.
<i>Accidents:</i> including plant or equipment failure; materials handling; vandalism; operator error; fire; and, flooding.	Over site surfaces; through site drainage systems; and through the air.	<i>Surface water; Groundwater; Ground; Atmosphere, and Humans including:</i> Facility workers/visitors; workers on adjacent premises; local residents; intermittent presence on pedestrian routes /

<b>Source</b>	<b>Potential Pathway</b>	<b>Receptor</b>
		roadways surrounding the Facility.
<i>Fugitive Emissions:</i> including dust; litter; and surface water run-off.	Through the air; windblown; over Facility surfaces; through Facility drainage systems.	<i>Surface water; groundwater; ground; atmosphere, and humans including:</i> facility workers/visitors; workers on adjacent premises; local residents; intermittent presence on pedestrian routes / roadways surrounding the brewery.
<i>Controlled release to air:</i> from point sources.	Through the air; windblown.	<i>Atmosphere, and humans including:</i> Facility workers/visitors; workers on adjacent premises; local residents; intermittent presence on pedestrian routes / roadways surrounding the brewery.
<i>Global Warming Potential:</i> from direct and indirect use of fossil fuels.	Through the air.	<i>Atmosphere.</i>
<i>Installation Waste:</i> hazardous and non-hazardous wastes arising as a result of production processes; maintenance; and administrative functions undertaken at the Facility.	Windblown over ground; surface water run-off.	<i>Groundwater; surface water; ground; and atmosphere.</i>

## 4. RISK ASSESSMENT METHODOLOGY

The risk assessment provides a simple representation of the hypothesised relationships between contaminants, pathways and receptors. This allows the identification of potential contamination linkages and, therefore, an interpretation of the potential for pollution to occur at the Facility or within the vicinity of the site as a result of the activities at the Facility.

The potential for pollution to occur at the site is determined by assessing the likelihood of an identified receptor being exposed to pollution emanating from a source at the Facility and the resultant consequences of any such exposure. In determining the likelihood and the consequence of a pollution exposure the risk management techniques which are used at the Facility, and the effect on any such exposure are considered. Where the risk management techniques are considered to have a mitigating impact, the resultant overall likelihood of the pollution exposure occurring and its consequences on a receptor are lowered.

### 4.1 Assessing Likelihood and Consequence

Within the risk assessment, each hypothesised relationship between contaminants, pathways and receptors is assessed to determine the likelihood of the receptor being exposed to pollution and the consequences of exposure using the rankings listed in the tables below.

**Table 4.1: Likelihood Rankings**

Very Low	Low	Medium	High
Exposure to pollution is considered to be <i>highly unlikely</i> .	Exposure is considered to be <i>unlikely</i> .	Exposure is considered to be <i>likely</i> .	Exposure is considered to be <i>highly likely</i> to occur.

**Table 4.2: Consequence Rankings**

Very Low	Low	Medium	High
No impact or imperceptible impact on the receptor.	Low level impact easily and quickly mitigated or may not require any intervention to rectify any impact.	Moderate impact which will not be rectified without some mitigation / intervention.	High impact requiring significant intervention / mitigation and may have caused irreparable damage to the receptor.

### 4.2 Assessment of Risk

Following the determination of the likelihood and consequence rankings for the hypothesised relationships developed using the source-pathway-receptor concept, the matrix in the table below is used to determine the overall risk of the pollution exposure occurring.

**Table 4.3 Risk Matrix**

		Likelihood			
		Very Low	Low	Medium	High
Consequence	High	Low	Medium	High	High
	Medium	Low	Medium	Medium	High
	Low	Low	Low	Medium	Medium
	Very Low	Very Low	Low	Low	Low

## 5. RISK ASSESSMENT

### 5.1 Controlled Discharge to Surface Water

The Operator is permitted to discharge to surface water at three locations; two at the ETP (uncontaminated surface water to the Mill Reen and treated effluent discharge from the ETP to the Severn Estuary) and one at the main brewery site (uncontaminated surface water to the Waundeilad Reen). The Permit stipulates that, for the discharge from the ETP to the Severn Estuary, continuous flow monitoring is required, and that the volume of discharge is not to exceed 10,000m<sup>3</sup> per day or 126 l/s. Continuous monitoring is also required for pH, which is required to be >5 and <9 and temperature, which has a maximum limit of 30°C. In addition, the permit stipulates that current discharge limits are: 200 mg/l biochemical oxygen demand (BOD); 150 mg/l suspended solids; 0.01 mg/l Total copper; 0.005 mg/l Total cadmium; 0.015 mg/l Total chromium; 0.0005 Total mercury, 0.03 mg/l Total nickel; 0.07 mg/l Total zinc; and 0.025 mg/l Total arsenic.

*The 2019 application to vary the EP includes the addition of a discharge of surface water runoff from the new lorry park at the south of the site, to highways drainage (discharge point W5).*

Management of the off-site ETP and the discharge to the estuary is contracted to Suez, who are responsible for all monitoring of the discharge, and for investigating and reporting any exceedances to the main brewery site. Suez reported one incident during 2017 of an exceedance of the permitted temperature limit of 30°C, by a discharge measured at 31.8°C. The exceedance was measured during a period of weather with extreme temperatures, and was reported to be caused by natural heating of the water. The exceedance was reported to NRW who did not consider the exceedance to be a breach. In addition, a pollution incident occurred during September 2017 when a pump at the off-site ETP failed, allowing an uncontrolled discharge to surface water. Further information on the incident and corrective action is provided in section 6 of the SCR.

*Ramboll anticipates that tighter discharge limits may be stipulated following the publishing of the reviewed Food & Drink BREF. The Operator is in discussion with NRW regarding how this will affect current operations.*

**Table 5.1: Controlled Discharge to Surface Water**

Source-Pathway-Receptor Hypothetical Model			Risk Management Techniques	Assessing the Risk		
Source of Pollution	Receptor	Pathway		Likelihood of Exposure	Consequence of Exposure	Overall Risk
Controlled Discharge to Surface Water: out of specification effluent	Severn Estuary (SSSI, SAC, SPA, Ramsar)	Below ground pipe	<ul style="list-style-type: none"> <li>Trade effluent is managed by Suez, who monitor effluent at all stages of the process to identify the potential for, and prevent the occurrence of, any exceedances of the parameters stipulated in the Environmental Permit. The actions to be taken, and personnel responsible, should there be an increased risk of an exceedance are documented in Suez's work instruction 'ONRAMS-OP-MAG-ABI-ETP-0069(1)- Action to be Taken in the Event of an Environmental Incident'.</li> <li>Suez use a SCADA system to automatically monitor effluent at certain points, from when it leaves the on-site wastewater treatment plant, throughout the process, to final discharge to surface water. Suez have set thresholds which, if exceeded, SCADA sends an automatic alarm to connected mobile phones. If any threshold is exceeded, then effluent can be transferred to the calamity tank and gradually released back into the wastewater treatment process.</li> <li>Samples of final effluent are taken and analysed daily by Suez at the off-site ETP laboratory. Composite samples are sent to an external certified laboratory every 7 to 8 days for verification of Suez's data.</li> <li>Pumps and tanks are subject to a Planned Preventative Maintenance schedule to reduce the risk of out of specification effluent arising due to failure of equipment.</li> </ul>	Low	Medium	<b>Low</b>
	Mill Reen	Below ground pipe	<ul style="list-style-type: none"> <li>Surface water from the off-site ETP is passed through an interceptor prior to discharge to the Mill Reen. The interceptor is maintained on a 6-monthly basis.</li> </ul>	Medium	Medium	<b>Medium</b>
	Waundeilad Reen	Below ground pipe	<ul style="list-style-type: none"> <li>All surface water from the main brewery site is directed via the drainage system to the on-site waste water treatment plant, where it is combined with process effluent and pumped to the off-site ETP for treatment and discharge to the Severn Estuary.</li> <li>In the event of a flood, the dilution factor provided by the additional surface water is considered, and agreed by NRW, to be sufficient in diluting the process effluent to an acceptable level to discharge to the Waundeilad Reen. The pH of the discharge is monitored prior to discharge.</li> </ul>	Low	Low	<b>Low</b>

Source-Pathway-Receptor Hypothetical Model			Risk Management Techniques	Assessing the Risk		
Source of Pollution	Receptor	Pathway		Likelihood of Exposure	Consequence of Exposure	Overall Risk
<i>Controlled Discharge to Surface Water: pump failure</i>	Mill Reen	Surface water drainage	<ul style="list-style-type: none"> <li>With the exception of Pump Pit Zero and the Inlet Sump Pump, all pumps at the off-site ETP have a back-up pump. If a pump fails, the potential for the sump to overflow would arise, resulting in a potential release of untreated effluent to surface water. In the event of a pump failure or sump overflow, the SCADA system would send an automatic alarm to Suez. Out of manned ours, a member of Suez personnel is on call, who has remote access to the SCADA via laptop.</li> <li>In the event of failure, untreated effluent could be diverted to the Calamity Tank, which has the capacity to hold sixteen hours' worth of effluent. Effluent can then be re-circulated if required.</li> <li>In the event that the capacity of the Calamity Tank and other tanks is reached, the brewery would cease operations until the ETP was back in full operation.</li> </ul>	Medium	Medium	<b>Medium</b>
	Severn Estuary (SSSI, SAC, SPA, Ramsar)	Discharge pipeline	<ul style="list-style-type: none"> <li>In the event of failure of equipment at the off-site ETP, there is potential for effluent to be discharged to the estuary. Effluent is monitored by Suez during all stages of treatment, from the point it leaves the brewery, throughout the process, to final discharge.</li> </ul>	Low	Medium	<b>Medium</b>
	Waundeilad Reen	Surface water drainage	<ul style="list-style-type: none"> <li>Surface water at the main brewery site is retained on site, at the wastewater treatment plant by a penstock valve, before being pumped to the off-site ETP. In the event that the pump to the ETP fails, operations at the brewery would cease until the failure was corrected. Any effluent already in the drainage system would be collected by a tanker for disposal off-site.</li> </ul>	Low	Medium	<b>Low</b>
<i>Controlled Discharge to Surface Water: breach of the drainage system</i>	Gwent Levels SSSI Secondary A Aquifer	Directly from cracks in the drains to ground/ groundwater	<ul style="list-style-type: none"> <li>AB InBev is committed to undertaking a drainage condition survey of the entire site including the ETP and the effluent pipeline. It is anticipated that some drainage maintenance work will be required to maintain integrity.</li> </ul>	Medium	Medium	<b>Medium</b>
<i>Controlled Discharge to Surface Water: contamination of surface water</i>	Mill Reen Waundeilad Reen Gwent Levels SSSI Severn Estuary (SSSI, SAC, SPA, Ramsar)	Overland Via pump/ pipe	<ul style="list-style-type: none"> <li>Surface water at the brewery site combines with process effluent on-site, before being pumped to the ETP for treatment. Therefore, any small-scale contamination would be pH balanced and treated at the ETP prior to discharge.</li> <li>In the event of a flood, process water, diluted by surface water, is pumped to the Waundeilad Reen. It has been agreed with NRW that the dilution of process water by uncontaminated flood water would be sufficient to consider the discharge 'uncontaminated'. The pH of this effluent is monitored prior to discharge.</li> <li>In the event of potential contamination of surface water at the lorry park area, the spillage procedure is followed to prevent contaminated runoff from entering the drainage system.</li> </ul>	Low	Low	<b>Low</b>

## 5.2 Odour

The potential sources of odour at the Facility have been identified and used to develop the risk assessment for odour (see Table 5.2 below). There are no records of complaints relating to odour at the main brewery site; however historically there have been odour complaints at the ETP, from a local landowner. There have been no complaints relating to odour at either site in recent years.

**Table 5.2: Odour**

Source-Pathway-Receptor Hypothetical Model			Risk Management Techniques	Assessing the Risk		
Source of Pollution	Receptor	Pathway		Likelihood of Exposure	Consequence of Exposure	Overall Risk
<i>Odour: brewing process</i>	<i>Humans including: Facility workers/visitors; workers on adjacent premises; local residents; intermittent presence on pedestrian routes / roadways surrounding the Facility.</i>	Fugitive emissions to air from building openings / air handling units	<ul style="list-style-type: none"> <li>Fugitive emissions from buildings are minimised by fast-acting doors, keeping them closed whenever they are not needed for access.</li> </ul>	Medium	Low	<b>Low</b>
<i>Odour: waste materials</i>		Fugitive emissions to outdoor air	<ul style="list-style-type: none"> <li>Wastes produced at the site include general, card and plastics, waste cans and small amounts of hazardous wastes. These wastes are stored in designated covered containers and skips, and are considered to be at low risk of becoming malodorous.</li> <li>The wastes are stored at the 'Recycling Area', which is situated at a central location of the site, reducing the risk of odour from any waste reaching the site boundary.</li> <li>Frequent collections of wastes are scheduled.</li> </ul>	Low	Low	<b>Low</b>
<i>Odour: effluent at the on-site waste water treatment plant</i>		Fugitive emissions to outdoor air	<ul style="list-style-type: none"> <li>The on-site waste water treatment plant is located towards the south of the brewery site, away from the majority of human receptors on-site. The area is approximately 200 m from the nearest residential building; however, the warehouse buildings lie in between and would prevent any potential odour at the site boundary.</li> <li>Minimal treatment of the effluent is carried out on-site, and therefore the potential for offensive odours to be produced is low.</li> </ul>	Low	Low	<b>Low</b>
<i>Odour: operations at the off-site ETP</i>		Fugitive emissions to outdoor air	<ul style="list-style-type: none"> <li>The off-site ETP is situated on the coastline, in a remote location approximately 450 m from the nearest receptor.</li> <li>The performance and operation of the ETP is managed and monitored daily by Suez.</li> <li>Sludge is removed by a tanker daily. Although some odour is generated during sludge removal, the distance between the ETP and local receptors makes it unlikely that odour would cause a nuisance.</li> <li>High concentrations of hydrogen sulphide (H<sub>2</sub>S) had been observed at the ETP. Ramboll carried out an investigation into the causes of the elevated concentrations and recommended actions to reduce these levels (Report Ref: 1700003278-Magor Brewery Hydrogen Sulphide Investigation). The facility is currently implementing actions and planning to address the issue.</li> </ul>	Medium	Low	<b>Medium</b>

### 5.3 Noise

The potential sources of noise at the Facility have been identified and used to develop the risk assessment for noise (see Table 5.3 below). There is the potential for noise to arise through the transport and receipt of raw materials and through the collection and distribution of finished products and wastes by heavy goods vehicles. Forklift trucks are also used to transport goods on-site. Production processes including the boilers and steam are also potential sources of noise on the site. The risk assessment for individual noise sources is provided in the table below.

**Table 5.3: Noise**

Source-Pathway-Receptor Hypothetical Model			Risk Management Techniques	Assessing the Risk		
Source of Pollution	Receptor	Pathway		Likelihood of Exposure	Consequence of Exposure	Overall Risk
<i>Noise:</i> arising from the movement of heavy goods vehicles (HGVs) & forklift trucks across the Facility, and engine noise / alarms from other vehicles working on, and visiting the site.	<i>Humans including:</i> Facility workers/visitors; workers on adjacent premises; local residents; intermittent presence on pedestrian routes / roadways surrounding the factory	Through the air and ground vibration	<ul style="list-style-type: none"> <li>A site speed limit of 10 miles per hour is in operation across the Facility to minimise engine noise.</li> <li>The site is located close to Junction 23A of the M4 motorway, meaning disruption from transport vehicles off-site is minimised.</li> <li>The car park for operatives and visitors is located next to the site entrance minimising the movements of traffic on the site.</li> <li>Noise embankments have been built around the site perimeter to minimise the risk of noises on site travelling off-site.</li> </ul>	Low	Low	<b>Low</b>
<i>Noise and vibration:</i> arising from the operation of ancillary plant (comprising boiler, air compressors, chillers).			<ul style="list-style-type: none"> <li>The boilers and other process equipment is contained within buildings with fast-acting doors, minimising noise to the external environment.</li> <li>All plant at the site is maintained in accordance with manufacturers' specifications and managed through a Planned Preventative Maintenance schedule to minimise excessive noise from poor performance.</li> <li>Noise embankments have been built around the site perimeter to minimise the risk of noises on site travelling off-site.</li> </ul>	Low	Low	<b>Low</b>
<i>Noise and Vibration:</i> arising from the internal handling of raw materials and production equipment.			<ul style="list-style-type: none"> <li>All production processes are undertaken within buildings.</li> <li>Fast-acting building doors are kept closed whenever they are not needed for access.</li> <li>All plant is maintained periodically in accordance with manufacturers' specifications to minimise excessive noise from poor performance.</li> </ul>	Low	Low	<b>Low</b>
<i>Noise and Vibration:</i> arising from vehicles and operations at the off-site ETP.			<ul style="list-style-type: none"> <li>The remote location of the off-site ETP restricts noise disturbance from its operations.</li> <li>Waste collections from the off-site ETP are restricted to between the hours of 7:30 and 16:30.</li> </ul>	Low	Low	<b>Low</b>

## 5.4 Accidents

The risk assessment for accidents at the site is included in the table below.

**Table 5.4: Accidents**

Source-Pathway-Receptor Hypothetical Model			Risk Management Techniques	Assessing the Risk		
Source of Pollution	Receptor	Pathway		Likelihood of Exposure	Consequence of Exposure	Overall Risk
<p><i>Accident:</i> Failure in containment of diesel oil storage tank (or other bulk storage) and associated equipment (valves, pipes etc.). Overfilling of oil tank or other spillage / operator error during filling or decanting from tank.</p>	Ground	Over Installation surfaces; and, through Installation drainage systems.	<ul style="list-style-type: none"> <li>The Facility maintains a register of bulk storage tanks/ containers and their contents. All bulk storage is provided with secondary bunding. An assessment of bunding was carried out by Ramboll in December 2018/ January 2019 and maintenance is ongoing.</li> <li>The Facility has a spillage emergency response procedure in place which is detailed in the EMS and the Accident Management Plan (dated November 2018).</li> <li>In the event that primary and secondary containment of a substance failed, the substance may enter the site drainage system. The substance could either be retained on-site and collected by tanker; or personnel at the main brewery site would alert personnel at the off-site WWTP to allow time for preparation for appropriate treatment. From the off-site WWTP, the substance could be diverted to the Calamity Tank and drip-fed through the process, to add a dilution factor; or could be collected from the off-site by tanker.</li> <li>The Facility is committed to commissioning a CCTV drainage survey to inspect the integrity of site drainage, i.e. in order to ensure there are no pathways to groundwater or surface water.</li> </ul>	Medium	Medium	<b>Medium</b>
	Groundwater					
	Surface Water					
<p><i>Accident:</i> Failure in containment of effluent storage: various tanks, sumps and associated equipment (valves, pipes etc.).</p>	Ground	Over surfaces & through drainage systems Directly into the Severn Estuary, Waundeilad Reen or Mill Reen.	<ul style="list-style-type: none"> <li>In the event of containment failure at the off-site ETP, untreated effluent could be diverted to the Calamity Tank, which has the capacity to hold sixteen hours' worth of effluent.</li> <li>In the event that the capacity of the Calamity Tank and other tanks is reached, the brewery would cease operations until the ETP was back in full operation.</li> <li>In the event of pump failure, most pumps have a back-up that would be automatically engaged.</li> <li>The Axel-Maint maintenance system used by Suez produces daily tasks, based on daily, monthly or weekly schedules. All assets at the off-site ETP are included on the Axel-Maint platform, including containment and bunding.</li> <li>In the event of a spillage at the off-site ETP, Suez follow the work instruction 'ONRAMS-OP-MAG-ABI-ETP-0070(1)- Response to a Chemical Spill at the BTS'.</li> </ul>	Medium	Low	<b>Medium</b>
	Groundwater			Medium	Medium	<b>Medium</b>
	Surface Water			Medium	Medium	<b>Medium</b>
	Atmosphere	Odours directly to outdoor air	<ul style="list-style-type: none"> <li>The off-site ETP is situated on the coastline, in a remote location approximately 450 m from the nearest receptor.</li> <li>The performance and operation of the ETP is managed and monitored daily by Suez.</li> <li>Sludge is removed by a tanker daily. Although some odour is generated during sludge removal, the distance between the ETP and local receptors makes it unlikely that odour would cause a nuisance.</li> </ul>	Medium	Low	<b>Medium</b>
<p><i>Accident:</i> release from ammonia tank</p>	Atmosphere	Odour directly to outdoor air & potentially indoor air	<ul style="list-style-type: none"> <li>Ammonia is used in refrigeration plant at the facility, which is maintained as required, and at a minimum of 6-monthly intervals under a service contract with Integral. The plant is included in the facility's "SAP" (planned preventative maintenance schedule), which records required maintenance frequencies for infrastructure and equipment at the facility and send alerts when routine maintenance is due. Integral are on call 24/7 in case of an ammonia leak.</li> </ul>	Low	High	<b>Medium</b>

Source-Pathway-Receptor Hypothetical Model			Risk Management Techniques	Assessing the Risk		
Source of Pollution	Receptor	Pathway		Likelihood of Exposure	Consequence of Exposure	Overall Risk
			<ul style="list-style-type: none"> <li>Areas where ammonia are in use are fitted with automatic leak detection and alarms. In the event of a leak, the facility has implemented a response and evacuation procedure: Ammonia Emergency Evacuation Procedure.</li> </ul>			
	Surface water	Drainage system	<ul style="list-style-type: none"> <li>In the event of a leak of ammonia entering the drainage system, the facility has the potential to hold water at the on-site wastewater treatment plant. If effluent contaminated with ammonia had been pumped to the off-site ETP, Suez would be informed to allow them to prepare to treat the effluent appropriately.</li> </ul>	Low	High	<b>Medium</b>
<i>Accident: Spillage / Release of raw materials during internal handling and storage</i>	Ground	Through Facility drainage systems (it is noted that the pathway would only occur if a failure in the Facility drainage associated with the process effluent occurred).	<ul style="list-style-type: none"> <li>All internal areas of the Facility feature impermeable surfaces.</li> <li>Interceptors are present across the site and are inspected regularly, in line with the PPM schedule recorded via the Facility's 'SAP' system.</li> <li>All effluent from the production areas drains to the waste water treatment plant on-site prior to pumping to the off-site ETP.</li> <li>Spill kits are available in key risk areas.</li> <li>The spill response procedure is defined in sites Accident Management Plan, revised November 2018.</li> <li>In the event of a spillage at the off-site ETP, Suez follow the work instruction 'ONRAMS-OP-MAG-ABI-ETP-0070(1)- Response to a Chemical Spill at the BTS'.</li> </ul>	Low	Low	<b>Low</b>
	Groundwater			Low	Low	<b>Low</b>
	Surface Water			Low	Low	<b>Low</b>
<i>Accidents (Vandalism): Damage / theft of externally located equipment / tanks</i>	Ground	Over Facility surfaces; and, through drainage systems.	<ul style="list-style-type: none"> <li>CCTV covers the site, which is secured by fencing and with authorised access only. All visitors and contractors enter via the gatehouse, which is manned 24/7 by site security.</li> <li>The Facility is operational 24/7, 365 days a year, so is manned at all times.</li> <li>The off-site ETP is covered by CCTV, which is monitored remotely out of hours. The off-site is manned 7:30-16:30, 7 days a week and the gates are padlocked out of hours. Suez are on call at all times when personnel are not present at the ETP.</li> </ul>	Low	Low	<b>Low</b>
	Groundwater			Low	Low	<b>Low</b>
	Surface Water			Low	Low	<b>Low</b>
<i>Accidents (Fire): Fire and arson attacks</i>	Ground	Over Facility surfaces; through the air; and, through Installation drainage systems.	<ul style="list-style-type: none"> <li>A Site Emergency Evacuation Plan is in place along with departmental fire plans and fire risk assessments.</li> <li>Fire alarm systems are subject to monthly maintenance.</li> <li>Trained Fire Marshals are in place to respond to alarms.</li> <li>Firefighting equipment is available on site for handling small fires.</li> <li>Fire water would be discharged to the off-site ETP for treatment, or may be discharged to the Waundeilad Reen if it meets set criteria (e.g. pH).</li> <li>In the event of a fire at the off-site ETP, operations at the brewery would cease until the ETP was fully operational and able to effectively treat brewery effluent.</li> </ul>	Low	Low	<b>Low</b>
	Groundwater			Low	Low	<b>Low</b>
	Surface Water			Low	Low	<b>Low</b>
	Atmosphere			Low	Low	<b>Low</b>
<i>Accidents: Explosion</i>	Ground	Over Facility surfaces; through the air;	<ul style="list-style-type: none"> <li>In the Accident Management Plan (dated November 2018), areas at risk of explosion have been identified as: the boiler house (natural gas), brew house (cereal dust), refrigeration plant (ammonia), fork lift refuelling area, and the use of biogas for the CHP at the off-site ETP.</li> </ul>	Low	Low	<b>Low</b>

Source-Pathway-Receptor Hypothetical Model			Risk Management Techniques	Assessing the Risk		
Source of Pollution	Receptor	Pathway		Likelihood of Exposure	Consequence of Exposure	Overall Risk
	Groundwater	and, through Installation drainage systems.	<ul style="list-style-type: none"> <li>A DSEAR Assessment was undertaken during December 2018 and actions arising from the assessment are ongoing.</li> </ul>	Low	Low	<b>Low</b>
	Surface Water			Low	Low	<b>Low</b>
	Atmosphere			Low	Low	<b>Low</b>

## 5.5 Fugitive Emissions

The risk assessment for fugitive emissions is presented in the table below.

**Table 5.5: Fugitive Emissions**

Source-Pathway-Receptor Hypothetical Model			Risk Management Techniques	Assessing the Risk		
Source of Pollution	Receptor	Pathway		Likelihood of Exposure	Consequence of Exposure	Overall Risk
Fugitive Emissions: dust and particulates from production areas	Humans including: Facility workers/visitors; workers on adjacent premises; local residents; intermittent presence on pedestrian routes / roadways surrounding the factory.	Through the air	<ul style="list-style-type: none"> <li>Grains, yeast and rice are delivered to an internal area which is a designated ATEX area. In addition, the potential for fugitive emissions of dust arises from the grinding of grains in the Mill House. Emissions of dust from these internal areas to the environment is reduced by fast-acting doors, and by abatement equipment.</li> <li>The potential for emissions of dust in external areas arises from the collection of spent yeast and wood chip by lorry. Emissions of dust are minimised, however, due to the production process producing damp waste yeast rather than dry.</li> </ul>	Medium	Medium	<b>Medium</b>
	Atmosphere			Low	Low	<b>Low</b>
Fugitive Emissions: litter and debris from Facility activities	Humans including: Facility workers/visitors; workers on adjacent premises; local residents; intermittent presence on pedestrian routes / roadways surrounding the factory.	Through the air	<ul style="list-style-type: none"> <li>All wastes produced at the Facility are segregated and provided with suitable containment.</li> <li>All wastes are stored within a dedicated recycling and waste area close to the centre of the site, protecting the area from wind, and reducing the risk of litter being windblown.</li> <li>Wastes are stored either in a container skip or are baled ready for collection.</li> <li>Wastes at the Off-Site ETP are stored in wheelie bins and collected by Biffa as required.</li> </ul>	Low	Low	<b>Low</b>
Fugitive Emissions: surface water run-off from external areas at the brewery site	Surface Water	Through drainage systems	<ul style="list-style-type: none"> <li>Surface water run-off from site roofs and yard areas is directed via the surface water drainage system to the on-site waste water treatment plant, where it is combined with process effluent, pH-balanced, and then pumped to the Off-site ETP.</li> <li>In the event of a spill on site resulting in contamination of the surface water system, personnel at the Off-site ETP are alerted and the run-off is treated appropriately prior to discharge to the Severn Estuary.</li> <li>Although the Facility is permitted to discharge uncontaminated surface water to the Waundeilad Reen, this discharge point is only utilised in the event of a flood when the Off-site ETP would not cope with the volume of flood water. The flood water is tested for pH prior to release to the reen.</li> </ul> <p><i>The Facility is committed to undertaking a CCTV survey of the drainage system to establish whether there are any pathways from surface water to ground water.</i></p>	Medium	Medium	<b>Medium</b>
	Ground water					
Fugitive Emissions: surface water run-off from the Off-site ETP	Surface Water	Through drainage systems	<ul style="list-style-type: none"> <li>Surface water from the Off-site ETP flows through an interceptor prior to discharge to the Mill Reen. The interceptor is subject to 6-monthly emptying and maintenance.</li> <li>In the event of a spill at the Off-site ETP, surface water drainage channels are protected using the spill kit available.</li> </ul>	Medium	Medium	<b>Medium</b>
Fugitive Emissions: surface water run-off from the lorry park	Surface Water	Through drainage systems	<ul style="list-style-type: none"> <li>Surface water run-off from the lorry park area is to enter the municipal highways stormwater drainage system at discharge point W5.</li> <li>In the event of a spill at the lorry park, the emergency spillage response procedure is to be followed (as detailed in the EMS and the Accident Management Plan (dated November 2018)). Skill kits will be available at the location.</li> <li>All surface water runoff from the new lorry park area is to flow to a drainage channels, from where it is to be directed through a Kings Bypass Separator (or similar approved interceptor) to</li> </ul>	Low	Low	<b>Low</b>

Source-Pathway-Receptor Hypothetical Model			Risk Management Techniques	Assessing the Risk		
Source of Pollution	Receptor	Pathway		Likelihood of Exposure	Consequence of Exposure	Overall Risk
			remove any oil-type substances, before passing through a cellular storage tank to control flow to the municipal stormwater drainage system. Drainage plans have been provided in Appendix 1.			

**5.6 Controlled Releases to Air**

The risk assessment for controlled releases to air is presented in the table below.

Source-Pathway-Receptor Hypothetical Model			Risk Management Techniques	Assessing the Risk		
Source of Pollution	Receptor	Pathway		Likelihood of Exposure	Consequence of Exposure	Overall Risk
Controlled Releases to Air: Boiler Stack Emissions	Atmosphere	Through the air	<ul style="list-style-type: none"> <li>The Facility operates four boilers at the main brewery site with a combined thermal input of greater than 50 MW. The boilers are maintained under a Planned Preventative Maintenance schedule, and are operated and monitored in compliance with the Facility's Environmental Permit (BX7282IS) and Greenhouse Gas Emissions Permit (UK-W-IN-11421).</li> <li>A Flue-Ace heat recovery system has recently been installed and modelling has been carried out to estimate the effect on air emissions from the boiler (Appendix 2).</li> <li>Two redundant CHP plant are present at the Facility which were taken out of operation approximately six years ago. The Facility has no plans to reinstate the units in the future.</li> </ul>	High	Medium	<b>Medium</b>
	Humans including: Facility workers/visitors; workers on adjacent premises; local residents; intermittent presence on pedestrian routes / roadways surrounding the factory					
Controlled Releases to Air: CHP and biogas flare	Atmosphere	Through the air	<ul style="list-style-type: none"> <li>Process biogas produced at the Off-site ETP is burned to power a CHP plant, which is used to power the off-site. Approximately 50% of the gas produced is used by the CHP, with the remaining gas being flared off. Emissions from the CHP and the biogas flare are permitted and are monitored as required by the permit.</li> <li>The CHP is maintained under contract by Veolia.</li> </ul>	High	Medium	<b>Medium</b>
	Humans including: Facility workers/visitors; intermittent presence on pedestrian routes / roadways surrounding the factory					
Controlled Releases to Air: water vapour from cooling towers and evaporative condensers	Atmosphere	Through the air	<ul style="list-style-type: none"> <li>The emissions from these point sources comprises water vapour only.</li> </ul>	Low	Low	<b>Low</b>
	Humans including: Facility workers/visitors; workers on adjacent premises; local residents; intermittent presence on pedestrian routes / roadways surrounding the factory					

## 5.7 Global Warming Potential

**Table 5.7: Global Warming Potential**

Source-Pathway-Receptor Hypothetical Model			Risk Management Techniques	Assessing the Risk		
Source of Pollution	Receptor	Pathway		Likelihood of Exposure	Consequence of Exposure	Overall Risk
<i>Global Warming Potential:</i> Combustion of natural gas within boiler to support production processes resulting in direct emissions of greenhouse gasses	<i>Atmosphere</i>	Through the air	<ul style="list-style-type: none"> <li>The Facility operates four boilers at the main brewery site with a combined thermal input of greater than 50 MW. A Flue-Ace heat recovery system has recently been installed to recover heat to pre-heat the water for the boilers.</li> <li>The boilers are operated in accordance with the Facility's Environmental and Greenhouse Gas Emissions permits.</li> </ul>	High	Medium	<b>Medium</b>
<i>Global Warming Potential:</i> Combustion of biogas at the Off-site ETP resulting in direct emissions of greenhouse gasses	<i>Atmosphere</i>	Through the air	<ul style="list-style-type: none"> <li>Biogas produced at the off-site ETP is burned by a CHP plant, which is used to power the off-site. Approximately 50% of the gas produced is used by the CHP, with the remaining gas being flared off. Emissions from the CHP and the biogas flare are permitted and are monitored as required by the permit.</li> </ul>	Medium	Low	<b>Low</b>
<i>Global Warming Potential:</i> Use of grid-sourced electricity to support production processes resulting in in-direct emissions of greenhouse gasses.	<i>Atmosphere</i>	Through the air	<ul style="list-style-type: none"> <li>Energy consumption is monitored, recorded, and reported on a monthly basis to the corporate function in Europe.</li> <li>The Facility is investigating renewable energy sources for the future, including the potential to use solar power.</li> <li>The off-site ETP is powered by biogas produced during the effluent treatment process, reducing the amount of electricity used from the grid. If more electricity is produced than is needed, some electricity is fed back to the grid.</li> </ul>	High	Very Low	<b>Low</b>
<i>Global Warming Potential:</i> Use of refrigerant gases in the chiller systems in the Cold Store Warehouse & refrigerated trailers	<i>Atmosphere</i>	Through the air	<ul style="list-style-type: none"> <li>The comfort cooling systems at the Facility contain refrigerants including R410A, which is a hydro fluorocarbon (HFC), and a regulated greenhouse gas. The systems are maintained and leak checked by qualified personnel, under contract by Apleona.</li> </ul>	Medium	Medium	<b>Medium</b>

**5.8 Installation Waste**

**Table 5.8: Installation Waste**

Source-Pathway-Receptor Hypothetical Model			Risk Management Techniques	Assessing the Risk		
Source of Pollution	Receptor	Pathway		Likelihood of Exposure	Consequence of Exposure	Overall Risk
<p><i>Facility Waste:</i> Wastes which arise from production and administrative activities at the site comprising: card; plastic; general waste; food waste; metals; wood; Waste Electronic and Electrical Equipment (WEEE); batteries; waste oils; fluorescent tubes; and used spill kits.</p>	<p><i>Humans including:</i> Facility workers/visitors; workers on adjacent premises; local residents; intermittent presence on pedestrian routes / roadways surrounding the factory</p>	Through the air	<ul style="list-style-type: none"> <li>All wastes produced at the Facility are segregated and provided with suitable containment.</li> <li>All wastes are stored within a dedicated recycling and waste area close to the centre of the site, protecting the area from wind, and reducing the risk of litter being windblown.</li> <li>Wastes are stored either in a container skip or are baled ready for collection.</li> <li>Wastes at the off-site ETP are stored in wheelie bins and collected by Biffa as required.</li> <li>Wastes produced at the Facility are unlikely to produce significant quantities of leachate.</li> <li>The management of waste is contracted to Biffa, who manage storage and arrange collections on behalf of the Facility.</li> <li>All wastes removed from the Facility are recovered / disposed of at permitted facilities.</li> </ul>	Low	Low	<b>Low</b>
	Surface Water	Over Facility surfaces; and through drainage systems		Low	Low	<b>Low</b>
	Groundwater			Low	Low	<b>Low</b>
	Ground			Low	Low	<b>Low</b>
<p><i>Facility Waste:</i> Process effluent storage tank and sump and associated equipment (valves, pipes etc.); and ETP sludge</p>	Ground	Over Facility surfaces; and through drainage systems.	<ul style="list-style-type: none"> <li>All assets at the ETP are included in the Axel-Maint maintenance system, managed by Suez on behalf of the Facility. The system provides for daily, weekly, monthly and annual checks and maintenance of all equipment as necessary, and includes all equipment and infrastructure including tanks and bunds and pipework.</li> <li>In the event of equipment failure in the ETP, backup pumps are in place, and systems are in place to divert effluent to the Calamity Tank for holding if required.</li> <li>A SCADA system is used to monitor effluent, which sends automatic alarms and notifications in the event of an incident.</li> <li>Duty of care checks are completed for all waste contractors to ensure they are appropriately licensed for the carriage of waste.</li> <li>All wastes removed from the site is recovered / disposed of at permitted facilities.</li> </ul>	Medium	Low	<b>Medium</b>

## 6. ERA CONCLUSION

Ramboll has identified potential environmental risks at the Facility and determined the potential environmental impact arising from each risk. The assessment has demonstrated that with the appropriate management controls in place, risks identified are acceptable, i.e. low to medium.

## **APPENDIX 1 EXOVA AIR MODELLING REPORT**

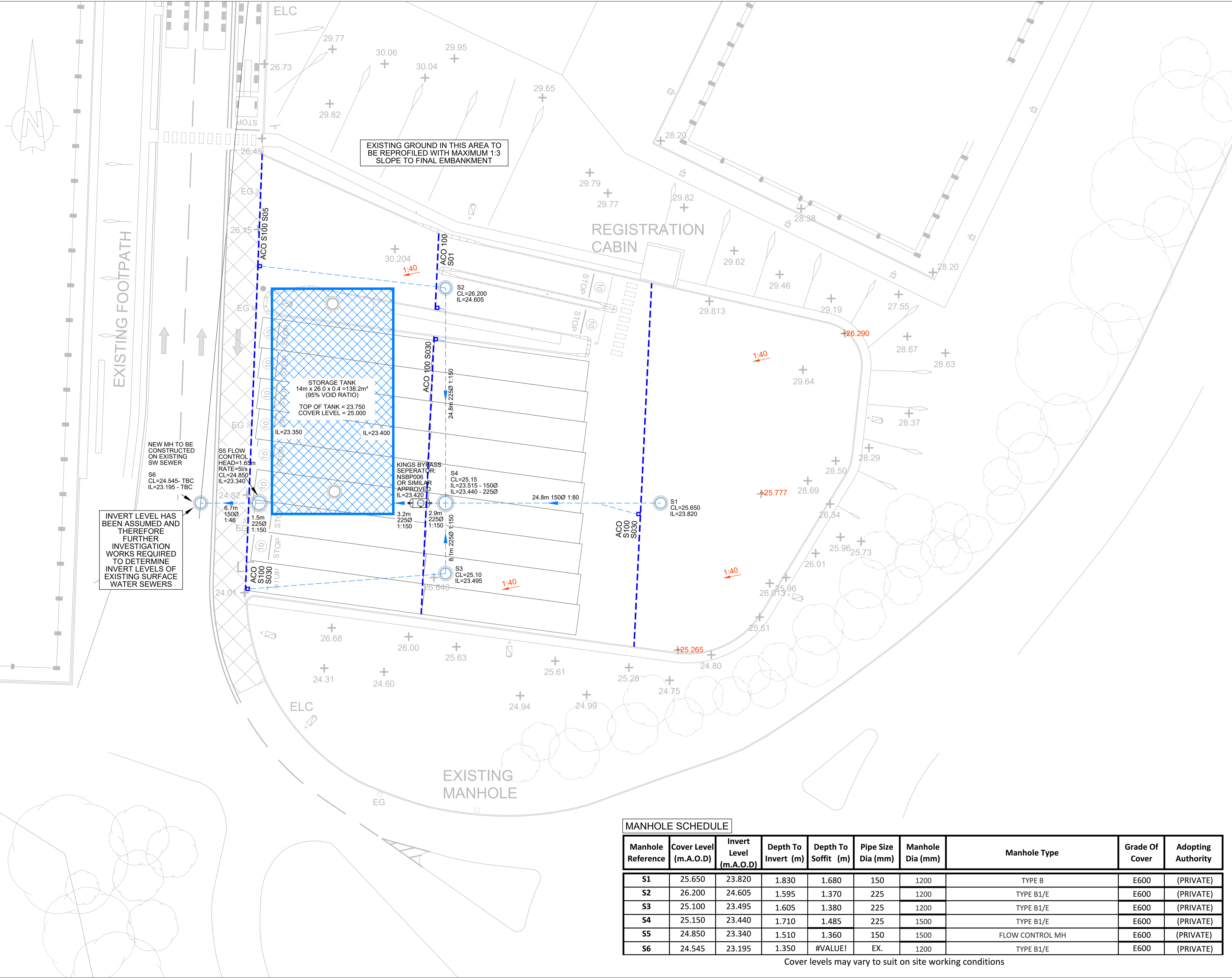

EXISTING GROUND IN THIS AREA TO BE REPROFILED WITH MAXIMUM 1:3 SLOPE TO FINAL EMBANKMENT

STORAGE TANK  
14m x 26.0 x 0.4 = 138.2m<sup>3</sup>  
(95% VOID RATIO)  
TOP OF TANK = 23.750  
COVER LEVEL = 25.000  
IL=23.350 IL=23.400

KINGS BYPASS SEPARATOR:  
NSBP006  
OR SIMILAR  
APPROVED  
IL=23.420

S4  
CL=25.15  
IL=23.515 - 1500  
IL=23.440 - 2250

S3  
CL=25.10  
IL=23.495

S1  
CL=25.650  
IL=23.820

NEW MH TO BE CONSTRUCTED ON EXISTING SW SEWER  
S6  
CL=24.545 - TBC  
IL=23.195 - TBC

INVERT LEVEL HAS BEEN ASSUMED AND THEREFORE FURTHER INVESTIGATION WORKS REQUIRED TO DETERMINE INVERT LEVELS OF EXISTING SURFACE WATER SEWERS

- GENERAL NOTES**
- 1.1. THIS DRAWING IS COPYRIGHT AND SHOULD NOT BE REPRODUCED IN WHOLE OR PART WITHOUT THE WRITTEN CONSENT OF PATRICK PARSONS LTD.
  - 1.2. DO NOT SCALE FROM THIS DRAWING.
  - 1.3. LOCATIONS OF ALL EXISTING SERVICES ON-SITE TO BE CONFIRMED & PROVIDED TO THE ENGINEER PRIOR TO COMMENCEMENT OF WORKS.
  - 1.4. THIS DRAWING IS TO BE READ IN CONJUNCTION WITH ALL RELEVANT PATRICK PARSONS LTD DRAWINGS & SPECIFICATIONS.
  - 1.5. ALL LEVELS TO BE CHECKED ON SITE BY CONTRACTOR AND ANY DISCREPANCIES REPORTED BACK TO THE ENGINEER PRIOR TO CONSTRUCTION.

**DRAINAGE STRATEGY**  
SURFACE WATER TO BE DISCHARGED TO EXISTING SEWER IN ACCESS ROAD AT A RESTRICTED RATE OF 5l/s.  
**THIS REQUIRES THE FOLLOWING STORAGE:**  
1 IN 30-YEAR = 74m<sup>3</sup>  
1 IN 100-YEAR + 20%CC = 138m<sup>3</sup>

- LEGEND**
- EXISTING SURFACE WATER SEWER
  - PROPOSED SURFACE WATER SEWER
  - PROPOSED SURFACE WATER CHAMBER
  - ACO CHANNEL DRAIN OR SIMILAR APPROVED
  - +61.32 EXISTING LEVEL
  - +61.32 PROPOSED LEVEL
  - 1:100 GRADIENT
  - DIRECTION OF FALL
  - ACCESS CHAMBER

P1	INITIAL ISSUE.	08.02.19	TE
Rev.	Amendments	Date	By

Revisions



5 Waverley Road  
Huddersfield  
West Yorkshire  
HD1 5NA  
United Kingdom  
T. +44 (0)1484 516 977  
E. info@patrickparsons.co.uk  
W. www.patrikparsons.co.uk

Client  
**AB INBEV UK LTD**

Project  
**HGV HOLDING AREA  
MAGOR**

Drawing  
**DRAINAGE LAYOUT**

Scales 1:200 At original size A1

Drawn TE  
Date FEB 2019  
Checked MJM

Status **PRELIMINARY**

Drawing No. **H18143-200** Rev. **P1**

**MANHOLE SCHEDULE**

Manhole Reference	Cover Level (m.A.O.D)	Invert Level (m.A.O.D)	Depth To Invert (m)	Depth To Soffit (m)	Pipe Size Dia (mm)	Manhole Dia (mm)	Manhole Type	Grade Of Cover	Adopting Authority
S1	25.650	23.820	1.830	1.680	150	1200	TYPE B	E600	(PRIVATE)
S2	26.200	24.605	1.595	1.370	225	1200	TYPE B1/E	E600	(PRIVATE)
S3	25.100	23.495	1.605	1.380	225	1200	TYPE B1/E	E600	(PRIVATE)
S4	25.150	23.440	1.710	1.485	225	1500	TYPE B1/E	E600	(PRIVATE)
S5	24.850	23.340	1.510	1.360	150	1500	FLOW CONTROL MH	E600	(PRIVATE)
S6	24.545	23.195	1.350	#VALUE!	EX.	1200	TYPE B1/E	E600	(PRIVATE)

Cover levels may vary to suit on site working conditions

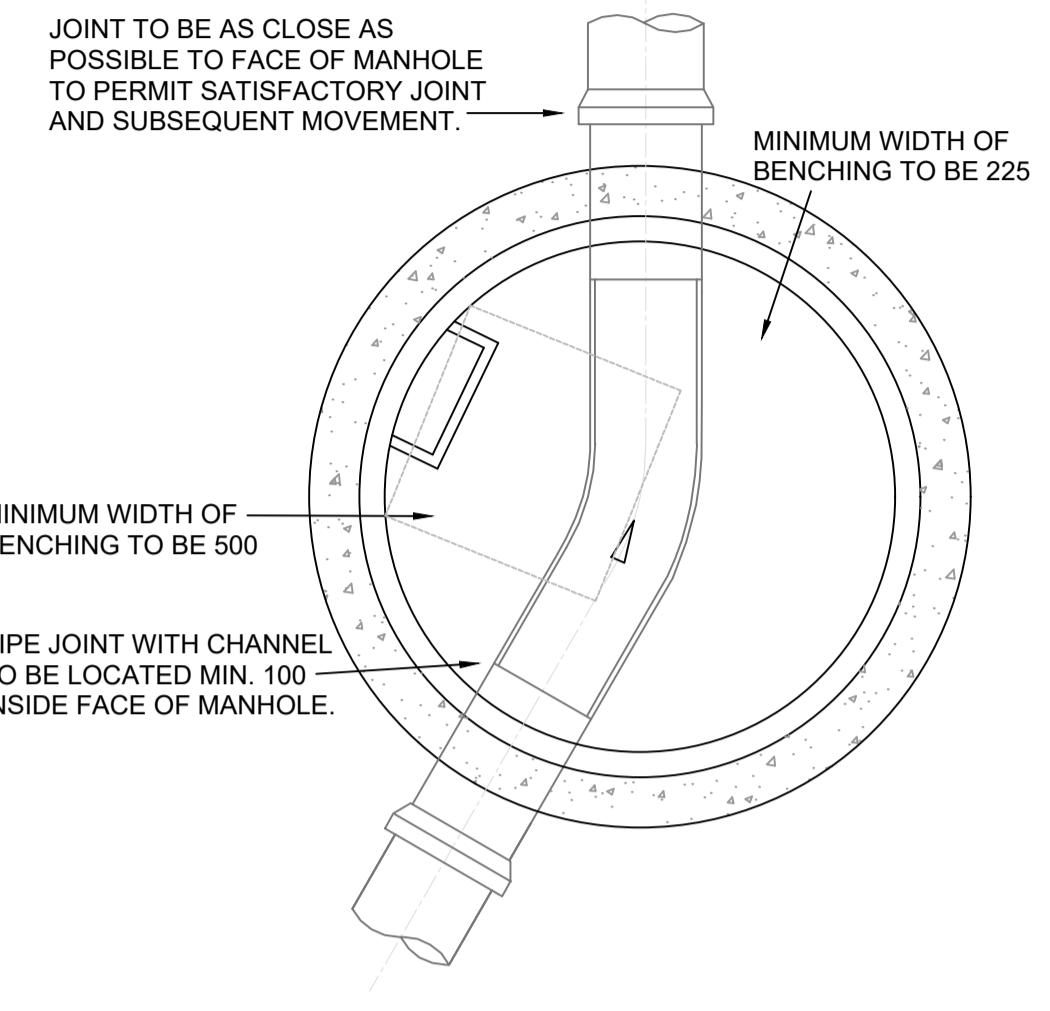
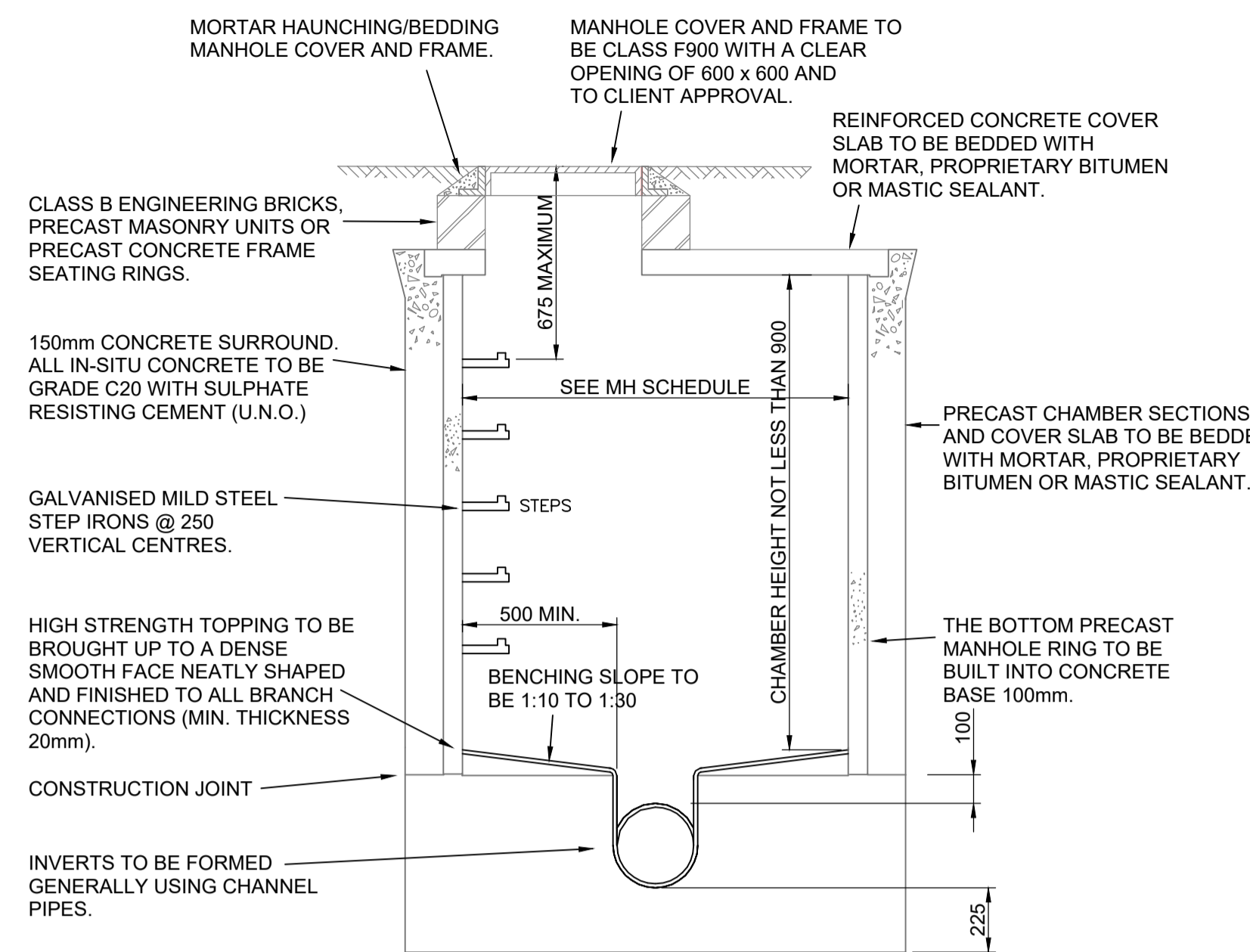

**TYPICAL MANHOLE DETAILS (GROUND LEVEL TO SOFFIT OF PIPE < 3m)**

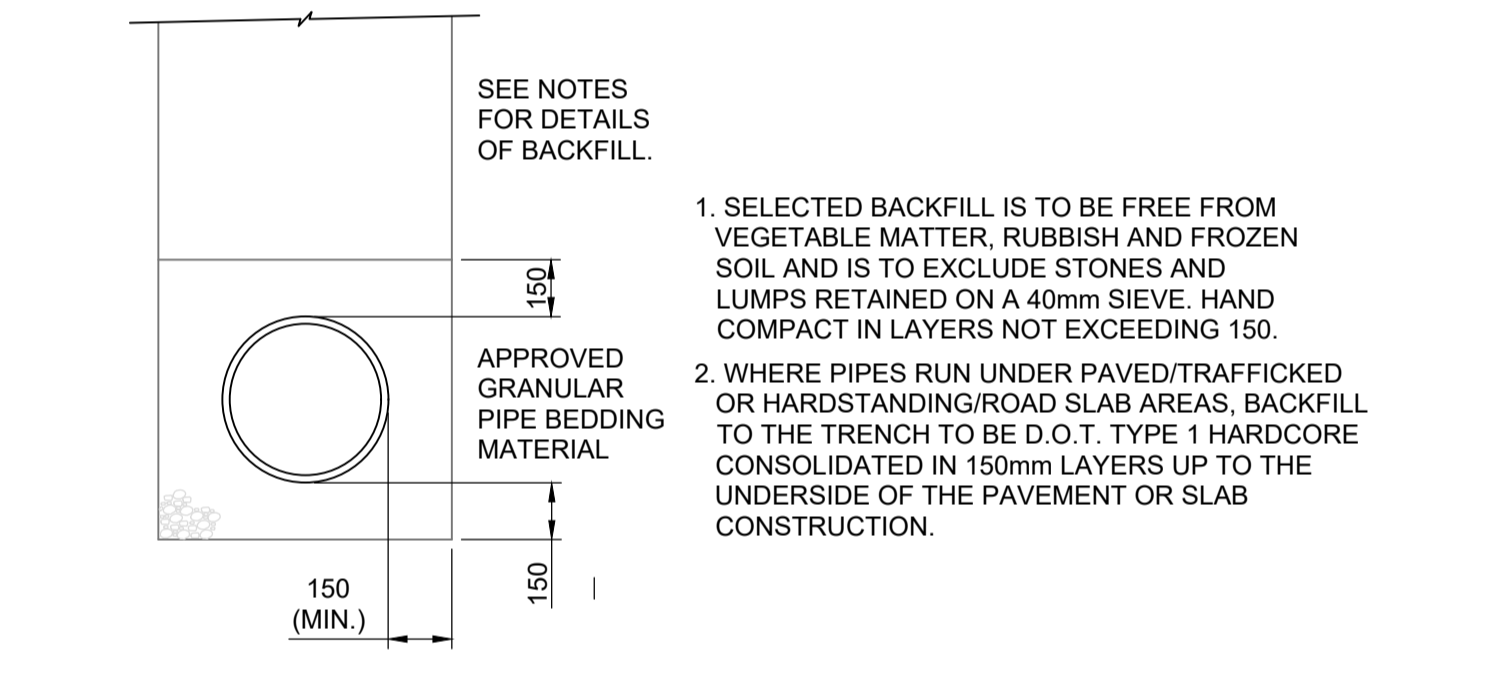
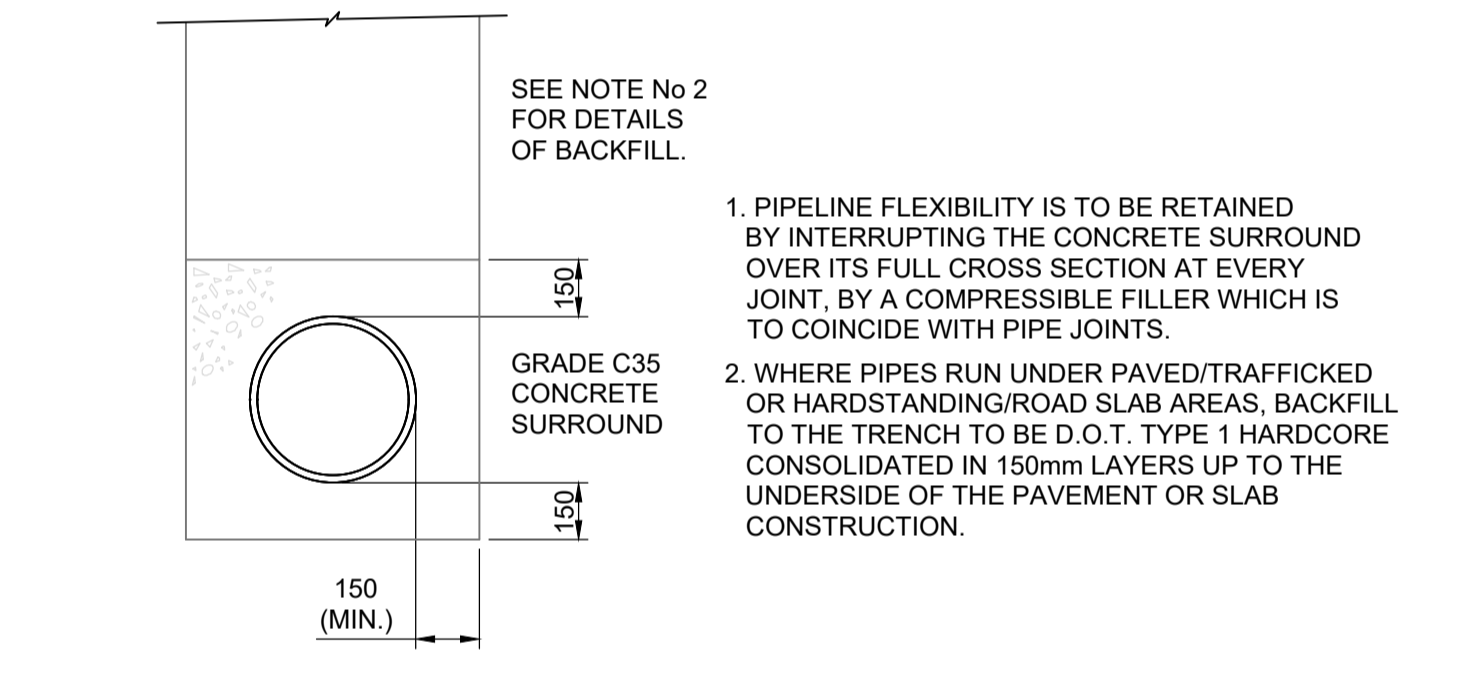

**TYPICAL PIPE BEDDING DETAIL WHERE COVER FROM GROUND TO PIPE SOFFIT LESS THAN 1200mm**

**TYPICAL PIPE BEDDING DETAIL WHERE COVER FROM GROUND TO PIPE SOFFIT GREATER THAN 1200mm**

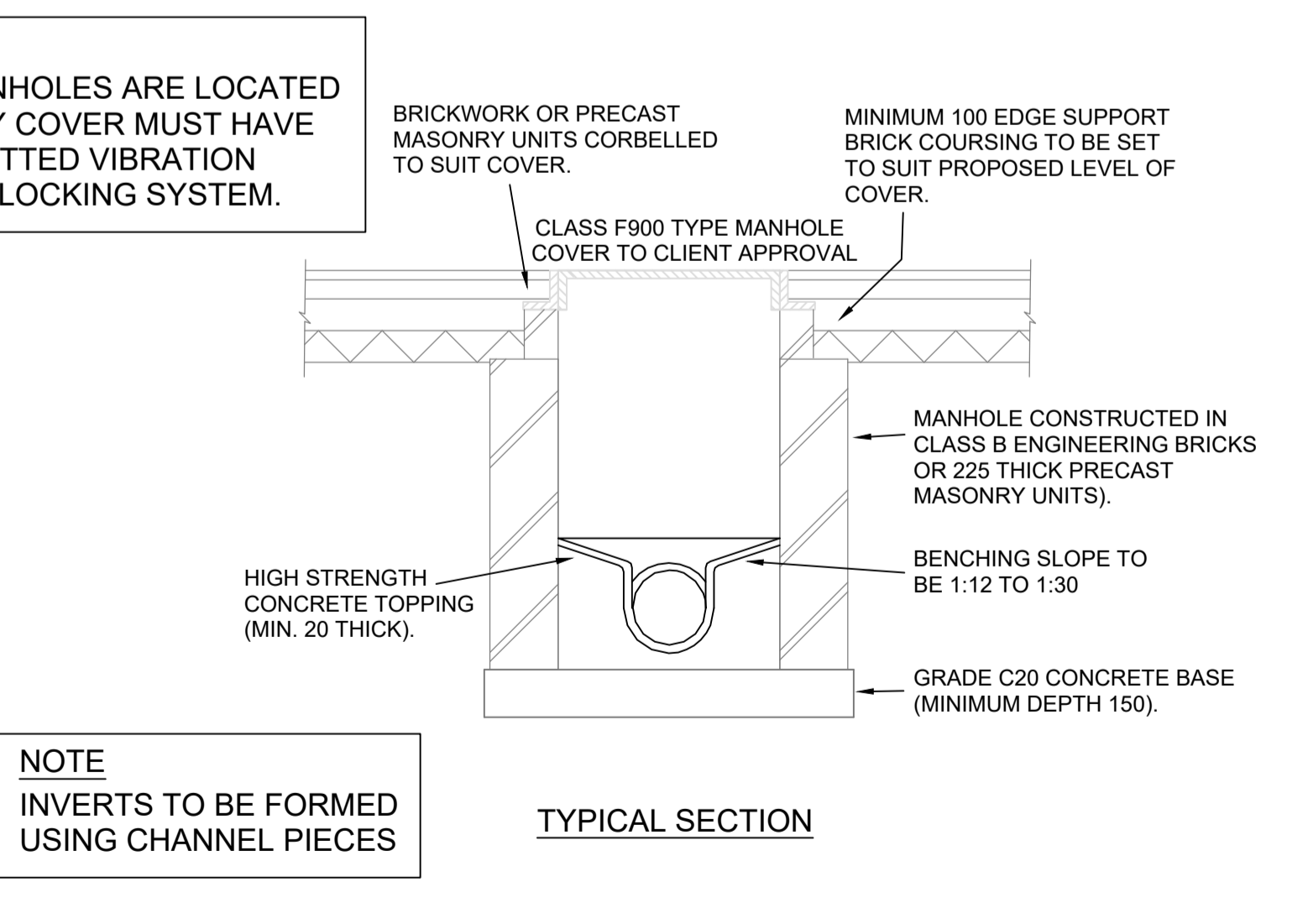
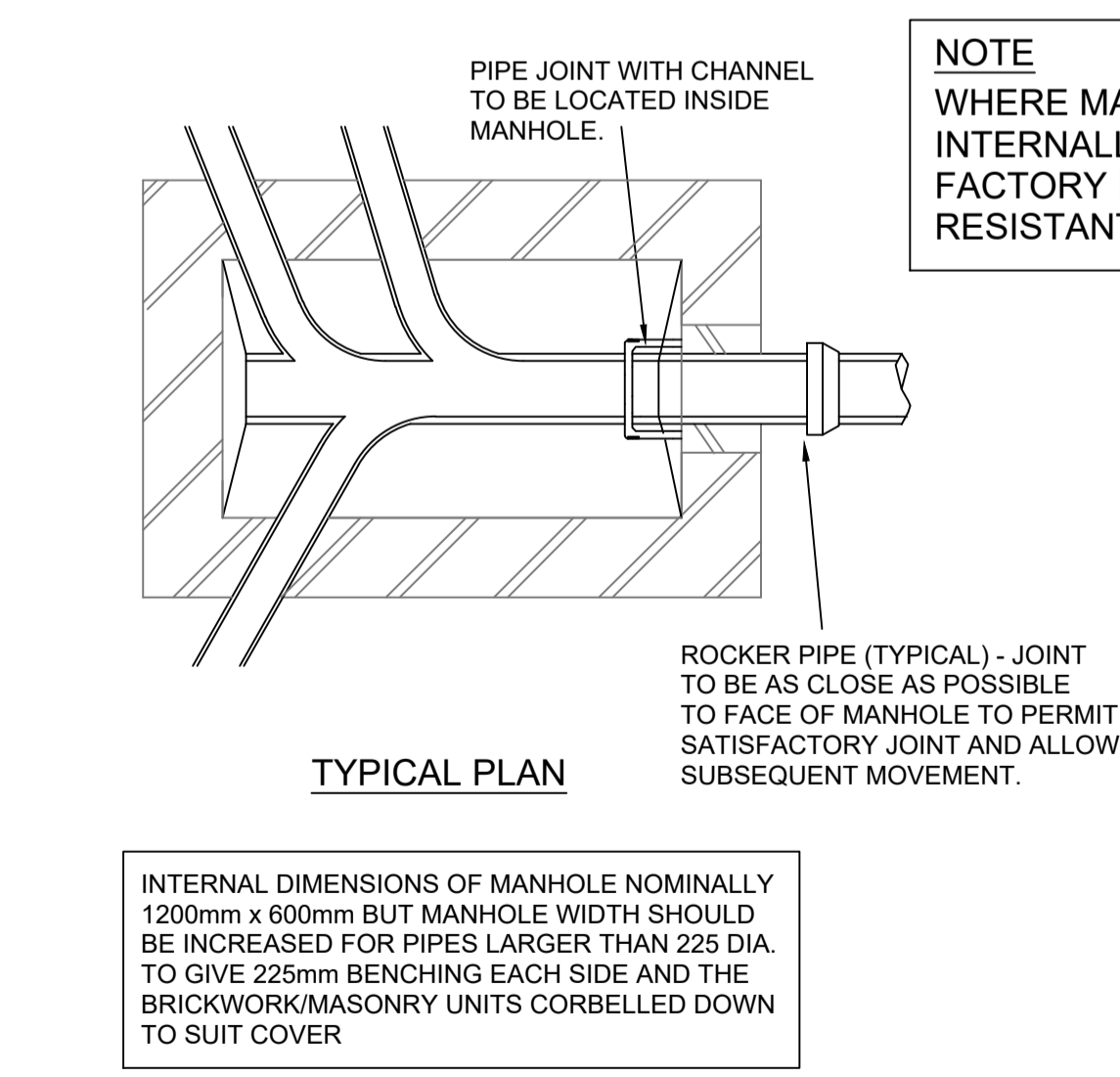

**TYPICAL MANHOLE DETAILS WHERE GROUND LEVEL TO PIPE SOFFIT LESS THAN 1.5m**

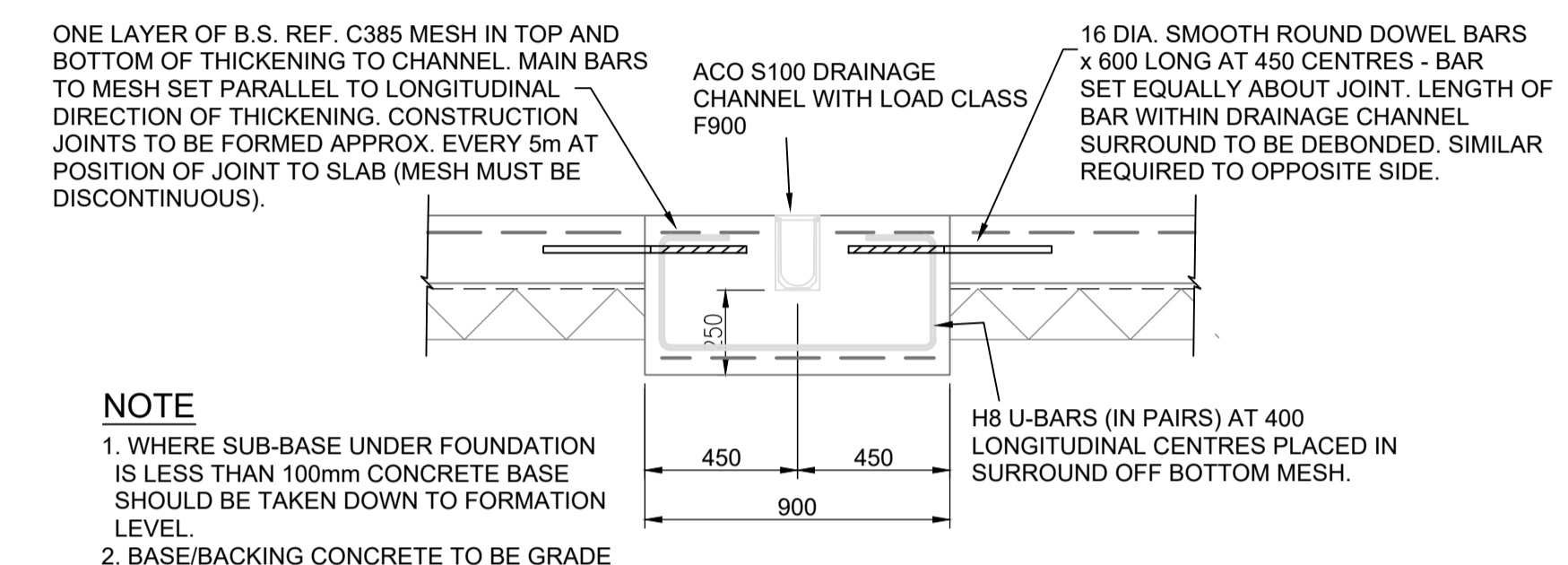

**TYPICAL DRAINAGE CHANNEL DETAIL (ALL DETAILS AS FOR TYPICAL HARDSTANDING U.N.O.)**

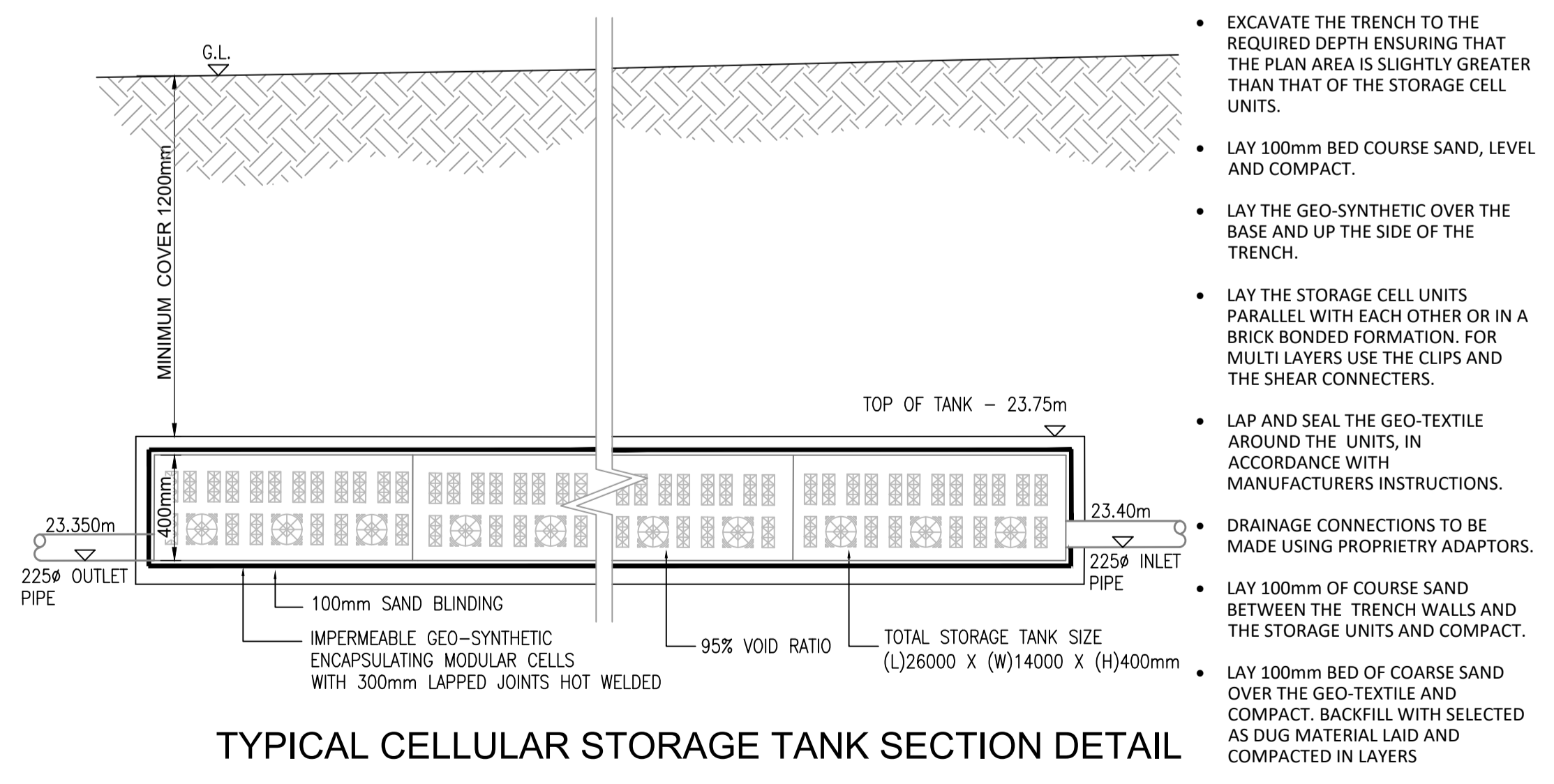

**TYPICAL CELLULAR STORAGE TANK SECTION DETAIL**

**GENERAL NOTES**  
 1.1. THIS DRAWING IS COPYRIGHT AND SHOULD NOT BE REPRODUCED IN WHOLE OR PART WITHOUT THE WRITTEN CONSENT OF PATRICK PARSONS LTD.  
 1.2. DO NOT SCALE FROM THIS DRAWING.  
 1.3. LOCATIONS OF ALL EXISTING SERVICES ON-SITE TO BE CONFIRMED & PROVIDED TO THE ENGINEER PRIOR TO COMMENCEMENT OF WORKS.  
 1.4. THIS DRAWING IS TO BE READ IN CONJUNCTION WITH ALL RELEVANT PATRICK PARSONS LTD DRAWINGS & SPECIFICATIONS.  
 1.5. ALL DETAILS TO BE CHECKED ON SITE BY CONTRACTOR AND ANY DISCREPANCIES REPORTED BACK TO THE ENGINEER PRIOR TO CONSTRUCTION.

P1	INITIAL ISSUE.	08.02.19	TE
Rev.	Amendments	Date	By

Revisions

**PATRICK PARSONS**

5 Waverley Road  
 Huddersfield  
 West Yorkshire  
 HD1 5NA  
 United Kingdom  
 T. +44 (0)1484 516 977  
 E. info@patrickparsons.co.uk  
 W. www.patrikparsons.co.uk

Client  
**AB InBev UK Ltd**

Project  
**HGV HOLDING AREA  
 MAGOR**

Drawing  
**DRAINAGE DETAILS**

Scales 1:200 At original size A1

Drawn TE  
 Date FEB 2019  
 Checked MJM

Status **PRELIMINARY**

Drawing No. **H18143-201** Rev. **P1**

## **APPENDIX 2 FLUE ACE AIR QUALITY ASSESSMENT**

**Inbev  
Mangor  
Air Quality Assessment  
NOx Emissions  
Flue Ace system**

**File reference number: CNE9N**

**February 2018**



<b>Project</b>	<b>NOx Air Quality Assessment</b>
<b>Client</b>	INBEV Mangor
<b>Report No:</b>	CNE9N
<b>Status &amp; Version</b>	Final
<b>Date of Release</b>	20/2/18

<b>Name</b>	<b>Signature</b>	<b>Position</b>	<b>Date</b>
Jeff hood		Senior Consultant	20/2/2018

This report is not to be used for contractual or engineering purposes unless the front cover sheet is signed where indicated by both the originator of the report and the approver and the report is designated 'Final' on the cover sheet.

## Table of contents

<b>1</b>	<b>Introduction .....</b>	<b>1</b>
1.1	Scope of the Assessment.....	2
<b>2</b>	<b>Receptors Considered for the Assessment .....</b>	<b>3</b>
<b>3</b>	<b>Criteria.....</b>	<b>4</b>
3.1	The UK Air Quality Standards and Objectives .....	4
<b>4</b>	<b>Existing and Future Background Air Quality .....</b>	<b>4</b>
<b>5</b>	<b>Industrial Emissions and Modelling Details .....</b>	<b>5</b>
5.1	Emissions Data for the Site .....	6
5.2	Modelling Details .....	7
<b>6</b>	<b>Assessment of Scenarios .....</b>	<b>8</b>
6.1	Scenario 1 – Flue Ace not operational .....	9
6.2	Scenario 2 – Flue Ace 100% .....	10
6.3	Scenario 3 – Flue Ace 50% .....	11
<b>7</b>	<b>Conclusions .....</b>	<b>12</b>

## Appendices

Appendix I Model Contour Plots

# Air Quality Assessment - NO<sub>x</sub> Impact

## 1 Introduction

The impact on NO<sub>x</sub> emissions from the works with the addition of an energy recovery system (Flue Ace )has been assessed. Three scenarios were assessed with the Flu Ace at 100%,50% and 0% operational. The output of the model will be compared with existing background NO<sub>x</sub> levels around the works and at the closest receptor locations. The Dispersion modelling package ISC-AERMOD has been used to determine the NO<sub>x</sub> impact from the works at these receptor locations.

The scenarios to be assessed have been selected through discussion with the site, and represent the existing scenario and possible options for the introduction of the energy recovery system. The results are presented as tabular data and in the form of contour plots, allowing comparisons to be made against the long and short-term Air Quality Standards as quoted within The Air Quality Strategy for England, Scotland, Wales & Northern Ireland.

The appraisal has been undertaken using manufacturers information or data from the most recent round of emissions testing performed at the site by Exova.

### Inbev Mangor works boundary

Inbev is situated to the east of the town of Mangor. The closest residents have been chosen as receptors to assess any impact on air quality from the works.



## Emission sources

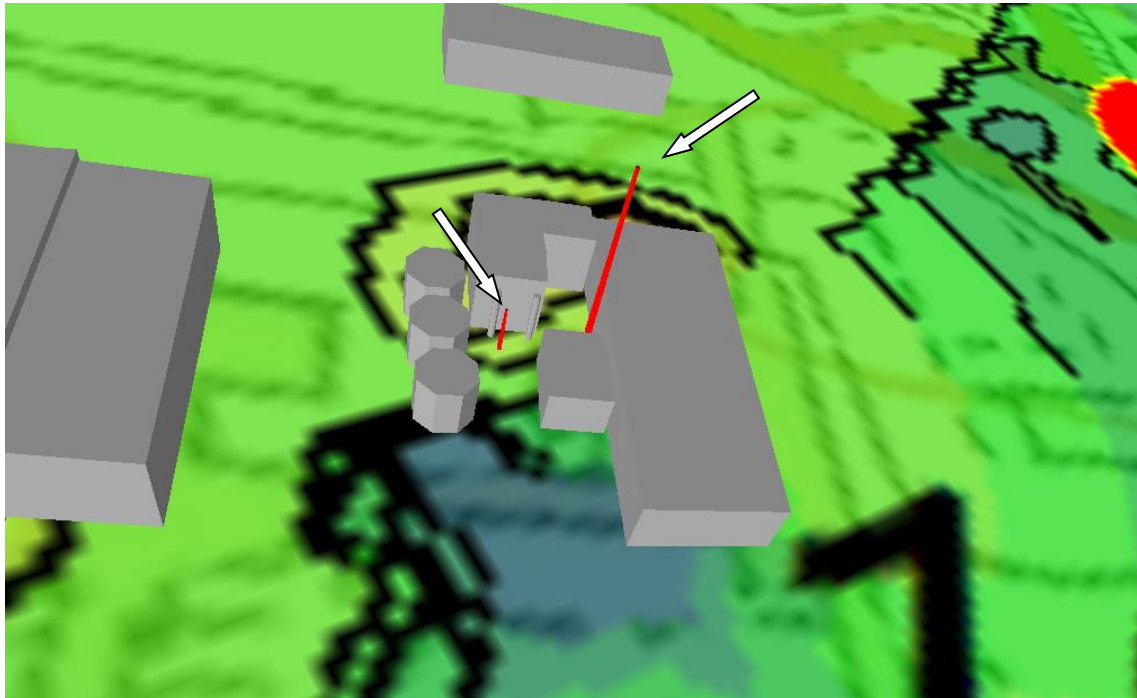

The emissions from the works have emission points that vent externally. Emission points are mechanically vented from chimney stacks.

## 1.1 Scope of the Assessment

An assessment was performed using dispersion modelling to determine the ground level concentrations of NO<sub>x</sub> that local residential areas will potentially be exposed.

The following aspects will be considered:

- The existing air quality in the locality - to allow addition of process contribution;
- The predicted impact on the air quality at surrounding residential properties as a consequence of NO<sub>x</sub> emissions for the following scenarios:

Scenario 1 Flue ace stack not operational 0% flow rate

Scenario 2 Flue ace stack 100% flow rate

Scenario 3 Flue ace stack 50% flow rate

- Future trends in background air quality that may affect the overall impact

## 2 Receptors and measurement locations considered within the Assessment

The location of the site and the position of the sensitive receptors considered in model are shown below.

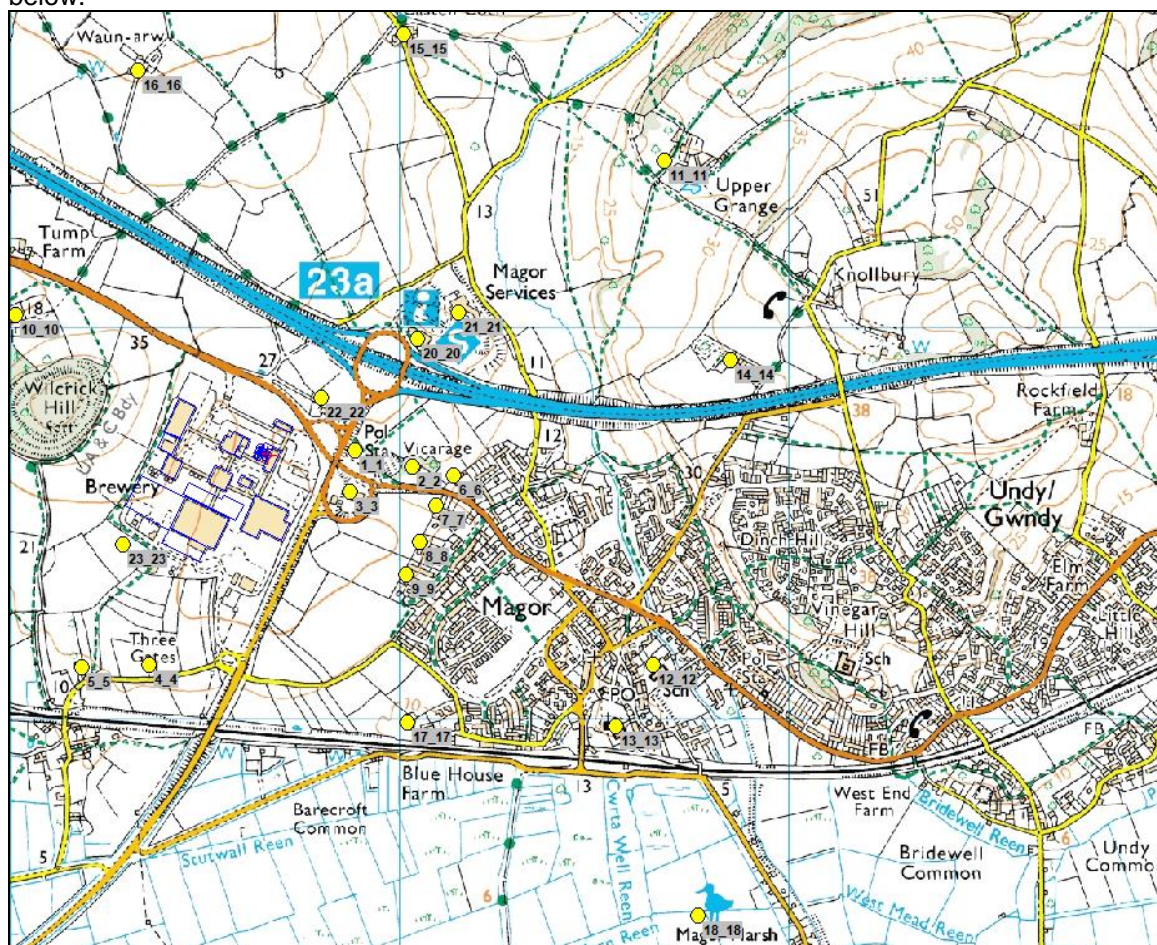

The closest receptors to the site which have been highlighted that could receive an increase percentage of the annual mean air quality standard.

### 3 Criteria

#### 3.1 The UK Air Quality Standards and Objectives

The UK Air Quality Strategy states a number of air quality standards and objectives with compliance dates, for the purposes of local air quality management. A summary of the objectives and standards taken from the National Air Quality Information Archive is provided below:

National air quality objectives and European Directive limit and target values for the protection of human health						
Pollutant	Applies	Objective	Concentration measured as <sup>1</sup>	Date to be achieved by (and maintained thereafter)	European Obligations	Date to be achieved by (and maintained thereafter)
Nitrogen dioxide	UK	200 µg/m <sup>3</sup> not to be exceeded more than 18 times a year	1 hour mean	31 December 2005	200 µg/m <sup>3</sup> not to be exceeded more than 18 times a year	1 January 2010
	UK	40 µg/m <sup>3</sup>	annual mean	31 December 2005	40 µg/m <sup>3</sup>	1 January 2010

National air quality objectives and European Directive limit and target values for the protection of vegetation and ecosystems						
Pollutant	Applies	Objective	Concentration measured as <sup>1</sup>	Date to be achieved by (and maintained thereafter)	European Obligations	Date to be achieved by (and maintained thereafter)
Nitrogen oxides	UK	30 µg/m <sup>3</sup>	annual mean	31 December 2000	30 µg/m <sup>3</sup>	19 July 2001

The Air Quality Standards for NO<sub>2</sub> which are highlighted above are considered to be the most relevant for making comparisons within this assessment.

### 4 Existing and Future Background Air Quality

In the diffusion tube monitoring information gathered has been compared with the derived background from the National Air Quality Information Archive. Figures have also been provided for predicted levels in 2018. The background values have been calculated for the square centred on the X and Y grid coordinates detailed below for the area surrounding the plant which resides in the X341500 Y187500 square.

X	Y	NO <sub>2</sub> 2017 ugm-3 as NO <sub>2</sub> annual mean	NO <sub>2</sub> 2018 ugm-3 as NO <sub>2</sub> annual mean
352500	18500	8.07	7.77
<b>341500</b>	<b>187500</b>	<b>12.86</b>	<b>12.36</b>
342500	187500	15.68	14.99

The figures indicate a downward trend in the predicted background NO<sub>2</sub> levels form 32% of the 40µg/m<sup>3</sup> annual mean UK Air Quality Standard in 2017, and 31% in 2018.

## 5 Industrial Emissions and Modelling Details

### 5.1 Emissions Data for the Site

The table below indicates the parameters modelled for the site, existing stack emissions are based upon the most recent emissions testing. These figures are assumed to be typical. Practical estimations have been made on fugitive emissions from doorways and roof vents.

Emission point	Release height (m)	NO <sub>x</sub> as NO <sub>2</sub> (g/s)	Gas Temperature (K)	Inside Duct diameter (m)	Gas exit Velocity (m/s)	Flow rate (m <sup>3</sup> /s)
Boiler main stack (boiler 2)	38	0.58	459	1.29	7.4	9.65
Flu Ace Stack 0%	9	0.0001	302	0.8	1.77	0.89
Flu Ace Stack 50%	9	0.734	383	0.8	9.07	4.56
Flu Ace Stack 100%	9	0.986	383	0.8	11.34	5.7

All predictions have been performed using operating times/conditions - 100% operation.

### 5.2 Modelling Details

The AERMOD dispersion model has been used to perform the predictions provided in the Appraisal Section and the contour maps in Appendix I. This model has been used extensively for assessing air quality impacts and is accepted as an appropriate air quality modelling tool by the EA, SEPA and local authorities. It is the regulatory model used by the USEPA.

Topographic features can have significant effect on the dispersion of pollutants, especially when the gradient exceeds 1 in 10. Terrain to the east of the site has a significant gradient and this needs to be taken into account. Terrain data provided by the Ordnance Survey has been used within the model. The terrain pre-processing module was utilised within the model to predict topographic effects and to generate elevations of receptors, buildings and stack bases.

5 years of meteorological data was used for the location. This data is thought to be representative of the met conditions experienced by the site and required no additional adjustment for local topography. The AERMET pre-processor provided the surface and profile files for the model. As the site is located in an urban area, the urban option was selected within the model to allow for any additional heating from properties. Seasonal surface roughness, Albedo figures and Bowen Ratios for each of 16 wind quadrants were used for the areas surrounding the site representing the urban landscape.

The buildings module was also utilised in each modelling run to allow for downwash. All major site buildings were input into the model. The revised building layout is indicated by the 3D visualisation below. The vertical height is exaggerated to illustrate the buildings more clearly.



Emissions of oxides of nitrogen from combustion processes are typically 95% nitric oxide (NO) or greater. Atmospheric reactions with ozone and oxygen cause the oxidation of NO to nitrogen dioxide (NO<sub>2</sub>). For the purposes of the modelling exercise, it has been assumed that there is 35% conversion of NO to NO<sub>2</sub> for the short-term concentrations and 70% conversion to NO<sub>2</sub> for the long term concentrations.

The area surrounding the site was modelled using a polar grid. The grid has a 20m ring spacing with 4 degree incremental radials.

The input data for this assessment has been compiled using a worst case scenario view point as typical furnace usage will be lower than the modelled run time values. This will tend to provide an overestimation of ground level concentrations and the actual figures are expected to be lower, or sometimes significantly lower.

Meteorological data has been used in the AERMOD dispersion model. Analysis of the worst case year for dispersion has been undertaken and was deemed to be 2015. Wind roses for a five year period are provided below.

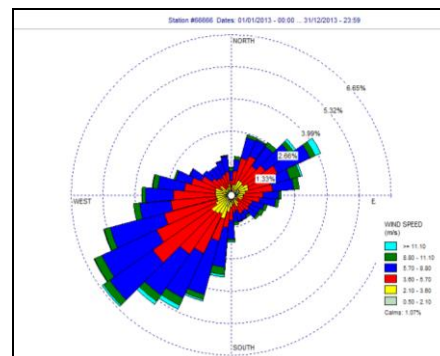
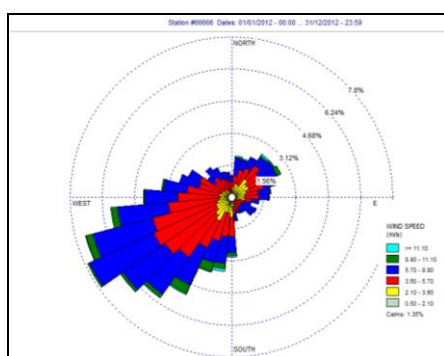

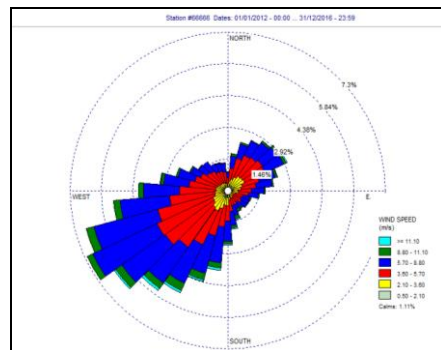
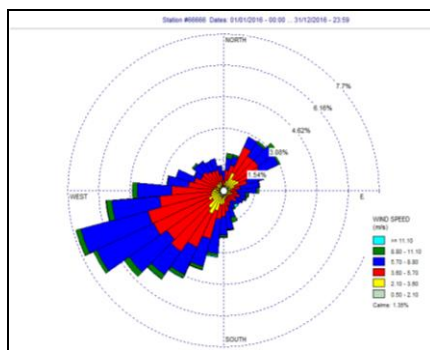
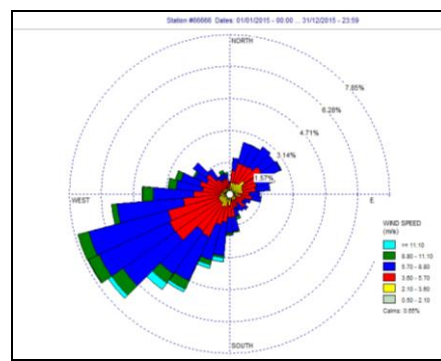
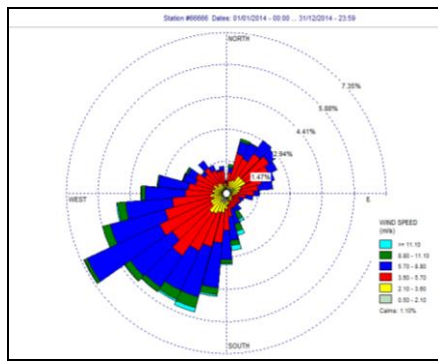

The wind roses indicate that typically the prevailing winds are from the west and south which will significantly affect the pattern of the long term concentrations of pollutants surrounding the site. Poorer dispersion usually occurs during periods of lighter winds, potentially giving rise to higher short term concentrations.

## 6.0 Assessment of Scenarios

The following scenarios have been considered within the assessment:

Scenario 1	Flue ace stack not operational 0% flow rate
Scenario 2	Flue ace stack 100% flow rate
Scenario 3	Flue ace stack 50% flow rate

The results of the dispersion modelling for each scenario are presented in this section and compare the predicted ground levels concentrations to the air quality standards applicable for the receptors surrounding the site. The predicted ground level concentrations are presented alongside a combined figure taking into account the background concentrations in the area as determined in Section 4.

H1 document provides criteria for assessing the significance of plant releases to be used for screening purposes within the H1 software tool, in order to decide whether more detailed modelling is required. These criteria may also be considered suitable for assessing the significance of the results obtained from the detailed modelling. Predicted ground level concentrations may be considered insignificant based on the following criteria:

- Long-term Process Contribution < 1% of the long-term environmental benchmark
- Short-term Process Contribution < 10% of the short-term environmental benchmark
- Short-term Process Contributions not exceeding 30% of the short-term benchmark “may be considered to be tolerable”

The short-term process contribution may be considered to be significant if it forms more than 20% of the headroom between the background concentration and the short term Air Quality Standard or EAL, or if the long-term Process Contribution plus background concentration (Predicted Environmental Concentration or PEC) is greater than 70% of the long term benchmark.

Predicted 2017 background concentrations in the area forms 31% of the long-term benchmark. A PEC of between 65% and 70% of the benchmark figures is deemed as being a borderline issue, whereas a PEC >70% of the benchmark must be re assessed.

As a consequence of the background figures, significant process additions are required for the PEC to exceed 65% of the benchmark. This means that achieving a PEC of <65% of the benchmark will be achievable with significant head space when operating the flue ace and boiler at 100% operation.

Contour plots for each scenario are presented in Appendix I.



## 6.1 Scenario 1

Table illustrates the predicted NO<sub>2</sub> concentrations at specific receptor positions for the worst case meteorological year (2015) boiler 2 with flue ace system off (0%).

### NO<sub>2</sub> Impacts at Sensitive Human Receptors and NO<sub>x</sub> Impacts at Sensitive Ecological Receptors

Boiler 2 with Flue ace 0% operational

			Predicted Ground Level Concentrations											
			NO <sub>2</sub> Annual Mean (µg/m <sup>3</sup> )				NO <sub>x</sub> Annual Mean (µg/m <sup>3</sup> )			NO <sub>2</sub> 99.79 %ile of 1hr means (µg/m <sup>3</sup> )				
Air Quality Standard (µg/m <sup>3</sup> )			40							200				
Vegetation based Air Quality Standard (µg/m <sup>3</sup> )			-				30			-				
Average Background NO <sub>x</sub> concentration (µg/m <sup>3</sup> )			-				19			-				
Average Background NO <sub>2</sub> concentration (µg/m <sup>3</sup> )			13				-			26				
Receptor Number	Receptor location		Process				Process			Process				
	X - Coordinates	Y - Coordinates	Contribution Excluding Background	PEC Including Background	Process Contrib as % of AQS	% PEC of AQS	Contribution Excluding Background	PEC Including Background	Process Contrib as % of Veg AQS	Contribution Excluding Background	PEC Including Background	Process Contrib as % of AQS	% PC of headroom	
1	341887.65	187683.25	0.33	13.3	0.8	33.3	0.47	19.5	1.6	3.04812	29.0	1.5	1.8	
2	342035.68	187640.27	0.36	13.4	0.9	33.4	0.52	19.5	1.7	3.27126	29.3	1.6	1.9	
3	341875.71	187575.8	0.19	13.2	0.5	33.0	0.27	19.3	0.9	3.12082	29.1	1.6	1.8	
4	341359.98	187134.09	0.16	13.2	0.4	32.9	0.22	19.2	0.7	2.38827	28.4	1.2	1.4	
5	341185.69	187129.32	0.13	13.1	0.3	32.8	0.19	19.2	0.6	2.13206	28.1	1.1	1.2	
6	342140.74	187618.78	0.29	13.3	0.7	33.2	0.41	19.4	1.4	2.8525	28.9	1.4	1.6	
7	342095.37	187542.38	0.24	13.2	0.6	33.1	0.35	19.3	1.2	2.95323	29.0	1.5	1.7	
8	342054.78	187449.26	0.20	13.2	0.5	33.0	0.29	19.3	1.0	3.00385	29.0	1.5	1.7	
9	342018.97	187365.69	0.17	13.2	0.4	32.9	0.24	19.2	0.8	3.06923	29.1	1.5	1.8	
10	341016.17	188029.45	0.06	13.1	0.2	32.7	0.09	19.1	0.3	2.20344	28.2	1.1	1.3	
11	342682.73	188423.41	0.14	13.1	0.3	32.8	0.19	19.2	0.6	1.57274	27.6	0.8	0.9	
12	342654.08	187134.09	0.07	13.1	0.2	32.7	0.10	19.1	0.3	1.50581	27.5	0.8	0.9	
13	342558.57	186976.51	0.06	13.1	0.1	32.6	0.09	19.1	0.3	1.45124	27.5	0.7	0.8	
14	342852.25	187914.85	0.13	13.1	0.3	32.8	0.19	19.2	0.6	1.65406	27.7	0.8	1.0	
15	342014.79	188745.75	0.09	13.1	0.2	32.7	0.13	19.1	0.4	1.55049	27.6	0.8	0.9	
16	341330.74	188652.63	0.04	13.0	0.1	32.6	0.06	19.1	0.2	1.59174	27.6	0.8	0.9	
17	342022.29	186987.48	0.06	13.1	0.2	32.7	0.09	19.1	0.3	1.78354	27.8	0.9	1.0	
18	342771.22	186492.89	0.03	13.0	0.1	32.6	0.04	19.0	0.1	0.95387	27.0	0.5	0.5	
19	343850.93	184869.88	0.01	13.0	0.0	32.5	0.01	19.0	0.0	0.38056	26.4	0.2	0.2	
20	342047.54	187968.39	0.50	13.5	1.3	33.8	0.72	19.7	2.4	3.06264	29.1	1.5	1.8	
21	342154.91	188034.85	0.38	13.4	0.9	33.4	0.54	19.5	1.8	2.50101	28.5	1.3	1.4	
22	341801.26	187816.99	0.40	13.4	1.0	33.5	0.57	19.6	1.9	3.15116	29.2	1.6	1.8	
23	341292.8	187440.59	0.23	13.2	0.6	33.1	0.32	19.3	1.1	3.08316	29.1	1.5	1.8	



## 6.2 Scenario 2

Table illustrates the predicted NO<sub>2</sub> concentrations at specific receptor positions for the worst case meteorological year (2015) Boiler 2 with flue ace at 100%.

			Predicted Ground Level Concentrations											
			NO <sub>2</sub> Annual Mean (µg/m <sup>3</sup> )				NO <sub>x</sub> Annual Mean (µg/m <sup>3</sup> )			NO <sub>2</sub> 99.79 %ile of 1hr means (µg/m <sup>3</sup> )				
Air Quality Standard (µg/m <sup>3</sup> )			40				30			200				
Vegetation based Air Quality Standard (µg/m <sup>3</sup> )			-				30			-				
Average Background NO <sub>x</sub> concentration (µg/m <sup>3</sup> )			-				19			-				
Average Background NO <sub>2</sub> concentration (µg/m <sup>3</sup> )			13				-			26				
Receptor Number	Receptor location		Process Contribution				Process Contribution			Process Contribution				
	X - Coordinates	Y - Coordinates	Excluding Background	PEC Including Background	Process Contrib as % of AQS	% PEC of AQS	Excluding Background	PEC Including Background	Contrib as % of Veg AQS	Excluding Background	PEC Including Background	Process Contrib as % of AQS	% PC of headroom	
1	341887.65	187683.25	4.37	17.4	10.9	43.4	6.24	25.2	20.8	35.8	61.8	17.9	20.5	
2	342035.68	187640.27	2.04	15.0	5.1	37.6	2.91	21.9	9.7	25.6	51.6	12.8	14.7	
3	341875.71	187575.8	2.83	15.8	7.1	39.6	4.04	23.0	13.5	35.8	61.8	17.9	20.6	
4	341359.98	187134.09	0.66	13.7	1.7	34.2	0.94	19.9	3.1	11.7	37.7	5.8	6.7	
5	341185.69	187129.32	0.52	13.5	1.3	33.8	0.74	19.7	2.5	9.5	35.5	4.8	5.5	
6	342140.74	187618.78	1.36	14.4	3.4	35.9	1.94	20.9	6.5	22.2	48.2	11.1	12.8	
7	342095.37	187542.38	1.27	14.3	3.2	35.7	1.81	20.8	6.0	23.4	49.4	11.7	13.5	
8	342054.78	187449.26	1.09	14.1	2.7	35.2	1.55	20.6	5.2	20.3	46.3	10.2	11.7	
9	342018.97	187365.69	0.92	13.9	2.3	34.8	1.32	20.3	4.4	27.0	53.0	13.5	15.5	
10	341016.17	188029.45	0.31	13.3	0.8	33.3	0.44	19.4	1.5	9.9	35.9	4.9	5.7	
11	342682.73	188423.41	0.42	13.4	1.1	33.6	0.61	19.6	2.0	6.0	32.0	3.0	3.5	
12	342654.08	187134.09	0.24	13.2	0.6	33.1	0.35	19.3	1.2	5.6	31.6	2.8	3.2	
13	342558.57	186976.51	0.22	13.2	0.6	33.1	0.31	19.3	1.0	5.9	31.9	2.9	3.4	
14	342852.25	187914.85	0.42	13.4	1.0	33.5	0.59	19.6	2.0	6.5	32.5	3.2	3.7	
15	342014.79	188745.75	0.30	13.3	0.8	33.3	0.43	19.4	1.4	5.5	31.5	2.7	3.1	
16	341330.74	188652.63	0.17	13.2	0.4	32.9	0.24	19.2	0.8	7.7	33.7	3.8	4.4	
17	342022.29	186987.48	0.29	13.3	0.7	33.2	0.42	19.4	1.4	7.9	33.9	4.0	4.6	
18	342771.22	186492.89	0.10	13.1	0.3	32.8	0.15	19.1	0.5	3.3	29.3	1.6	1.9	
19	343850.93	184869.88	0.03	13.0	0.1	32.6	0.04	19.0	0.1	1.1	27.1	0.6	0.7	
20	342047.54	187968.39	2.24	15.2	5.6	38.1	3.21	22.2	10.7	22.6	48.6	11.3	13.0	
21	342154.91	188034.85	1.41	14.4	3.5	36.0	2.01	21.0	6.7	13.3	39.3	6.7	7.7	
22	341801.26	187816.99	9.57	22.6	23.9	56.4	13.68	32.7	45.6	92.9	118.9	46.4	53.4	
23	341292.8	187440.59	1.26	14.3	3.2	35.7	1.80	20.8	6.0	21.7	47.7	10.9	12.5	



### 6.3 Scenario 3

Table illustrates the predicted NO<sub>2</sub> concentrations at specific receptor positions for the worst case meteorological year (2015) Boiler 2 with flue ace at 50%.

			Predicted Ground Level Concentrations										
			NO <sub>2</sub> Annual Mean (µg/m <sup>3</sup> )				NO <sub>x</sub> Annual Mean (µg/m <sup>3</sup> )			NO <sub>2</sub> 99.79 %ile of 1hr means (µg/m <sup>3</sup> )			
Air Quality Standard (µg/m <sup>3</sup> )			40				30			200			
Vegetation based Air Quality Standard (µg/m <sup>3</sup> )			-				30			-			
Average Background NO <sub>x</sub> concentration (µg/m <sup>3</sup> )			-				19			-			
Average Background NO <sub>2</sub> concentration (µg/m <sup>3</sup> )			13				-			26			
Receptor Number	Receptor location		Process Contribution Excluding Background				Process Contribution Excluding Background			Process Contribution Excluding Background			
	X - Coordinates	Y - Coordinates	PEC Including Background	Process Contrib as % of AQS	PEC of AQS	PEC Including Background	Process Contrib as % of Veg AQS	PEC Including Background	Process Contrib as % of AQS	PEC Including Background	Process Contrib as % of AQS	PEC of headroom	
1	341887.65	187683.25	3.61	16.6	9.0	41.5	5.16	24.2	17.2	31.4	57.4	15.7	18.0
2	342035.68	187640.27	1.64	14.6	4.1	36.6	2.34	21.3	7.8	19.8	45.8	9.9	11.4
3	341875.71	187575.8	2.26	15.3	5.6	38.1	3.23	22.2	10.8	28.2	54.2	14.1	16.2
4	341359.98	187134.09	0.55	13.5	1.4	33.9	0.78	19.8	2.6	9.3	35.3	4.6	5.3
5	341185.69	187129.32	0.43	13.4	1.1	33.6	0.61	19.6	2.0	7.5	33.5	3.7	4.3
6	342140.74	187618.78	1.09	14.1	2.7	35.2	1.56	20.6	5.2	15.0	41.0	7.5	8.6
7	342095.37	187542.38	1.02	14.0	2.6	35.1	1.46	20.5	4.9	18.7	44.7	9.3	10.7
8	342054.78	187449.26	0.88	13.9	2.2	34.7	1.25	20.3	4.2	13.6	39.6	6.8	7.8
9	342018.97	187365.69	0.74	13.7	1.8	34.3	1.06	20.1	3.5	13.5	39.5	6.8	7.8
10	341016.17	188029.45	0.25	13.3	0.6	33.1	0.36	19.4	1.2	8.0	34.0	4.0	4.6
11	342682.73	188423.41	0.35	13.4	0.9	33.4	0.51	19.5	1.7	4.9	30.9	2.4	2.8
12	342654.08	187134.09	0.20	13.2	0.5	33.0	0.29	19.3	1.0	4.6	30.6	2.3	2.6
13	342558.57	186976.51	0.18	13.2	0.5	33.0	0.26	19.3	0.9	4.3	30.3	2.1	2.5
14	342852.25	187914.85	0.34	13.3	0.9	33.4	0.49	19.5	1.6	5.0	31.0	2.5	2.9
15	342014.79	188745.75	0.25	13.3	0.6	33.1	0.36	19.4	1.2	4.7	30.7	2.3	2.7
16	341330.74	188652.63	0.14	13.1	0.4	32.9	0.20	19.2	0.7	6.3	32.3	3.1	3.6
17	342022.29	186987.48	0.24	13.2	0.6	33.1	0.34	19.3	1.1	6.3	32.3	3.1	3.6
18	342771.22	186492.89	0.09	13.1	0.2	32.7	0.12	19.1	0.4	2.7	28.7	1.3	1.5
19	343850.93	184869.88	0.02	13.0	0.1	32.6	0.03	19.0	0.1	0.9	26.9	0.5	0.5
20	342047.54	187968.39	1.84	14.8	4.6	37.1	2.62	21.6	8.7	17.8	43.8	8.9	10.2
21	342154.91	188034.85	1.17	14.2	2.9	35.4	1.68	20.7	5.6	11.1	37.1	5.6	6.4
22	341801.26	187816.99	7.23	20.2	18.1	50.6	10.33	29.3	34.4	69.2	95.2	34.6	39.8
23	341292.8	187440.59	1.21	14.2	3.0	35.5	1.73	20.7	5.8	23.9	49.9	12.0	13.7

## 7 Conclusions

An assessment of several operational scenarios has been performed for the Mangor site based upon viable options that exist for the plant. The ground level concentrations at nearby receptors have been predicted using AERMOD, a recognised Gaussian dispersion model. Metrological data from 2015 has been used in the model and represents the works case conditions of the last five years data.

The following scenarios have been modelled and represent a worst case situation:

Scenario 1	Flue ace stack not operational 0% flow rate
Scenario 2	Flue ace stack 100% flow rate
Scenario 3	Flue ace stack 50% flow rate

The long term NO<sub>2</sub> air quality standard is not predicted to be breached at any of the receptor positions for any of the options presented.

There are no exceedences of the short-term limit value even with the addition of background concentrations under any of the scenarios presented.

The findings for each of the scenarios are as follows:

- **Scenario 1)** Predicted PEC figures are <70% of the long-term AQS at all of the receptors considered. The short-term process contributions are not predicted to exceed 20% of the headroom at any of the receptors considered. The highest 1 hour average is predicted to be 29µg/m<sup>3</sup> and predictions therefore indicate that there will be no exceedances of the short-term limit value.
- **Scenario 2)** Predicted PEC figures are <70% of the long-term AQS at all of the receptors considered. The short-term process contributions are predicted to exceed 20% of the headroom at 3 receptor site considered. However, the highest 1 hour average is predicted to be 119µg/m<sup>3</sup> which indicates that there will be no exceedances of the short-term limit value.
- **Scenario 3)** Predicted PEC figures are <70% of the long-term AQS at all of the receptors considered. The short-term process contributions are predicted to exceed 20% of the headroom at 1 receptor considered. The highest 1 hour average at the receptor locations is predicted to be 95µg/m<sup>3</sup> which indicates that there will be no exceedances of the short-term limit value.

The following conclusions can be made:

- The modelling indicates that PEC's in the range of 32% and 56% of the long-term benchmark with no exceedances of the short-term limit value are predicted for both scenarios.
- Achieving a PEC of around 56% or less of the long-term AQS will provide a good margin for uncertainty and provide an allowance for local variations in background concentrations.
- All non-residential receptors gave predicted levels were well below the vegetation air quality standard.
- The addition of a new emission point on the works shows an increases in NO<sub>x</sub> at the closest residential receptors when operational. When assessed against the air quality standards the emissions are well below the long and short term limit values. The downward trend in background NO<sub>x</sub> levels will also have a positive impact on the percentage headroom of the AQS.

## Appendix I

### Annual average levels – Boiler 2 and Flue Ace 0%

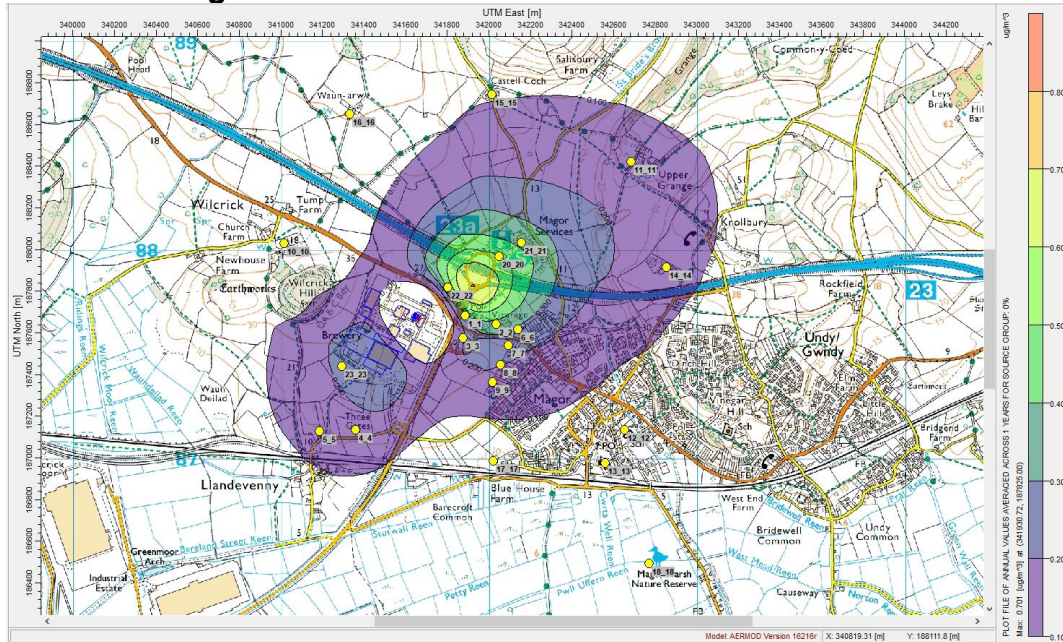

### Annual average levels - Boiler 2 and Flue Ace 50%

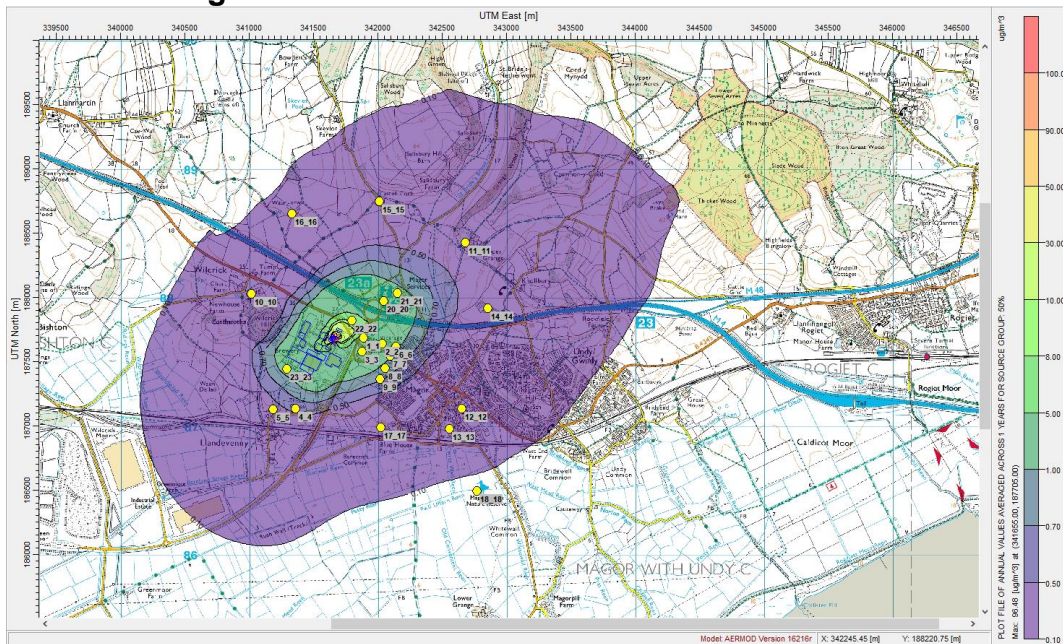

### Annual average levels - Boiler 2 and Flue Ace 100%

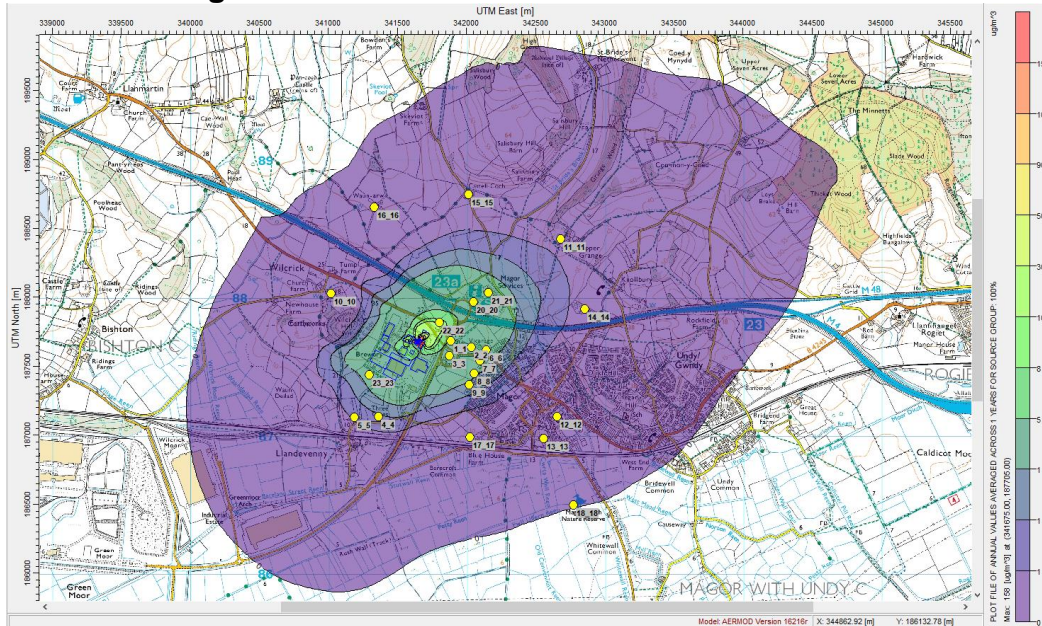

### 1hr 99.7th percentile levels Boiler 2 and Flue Ace 0%

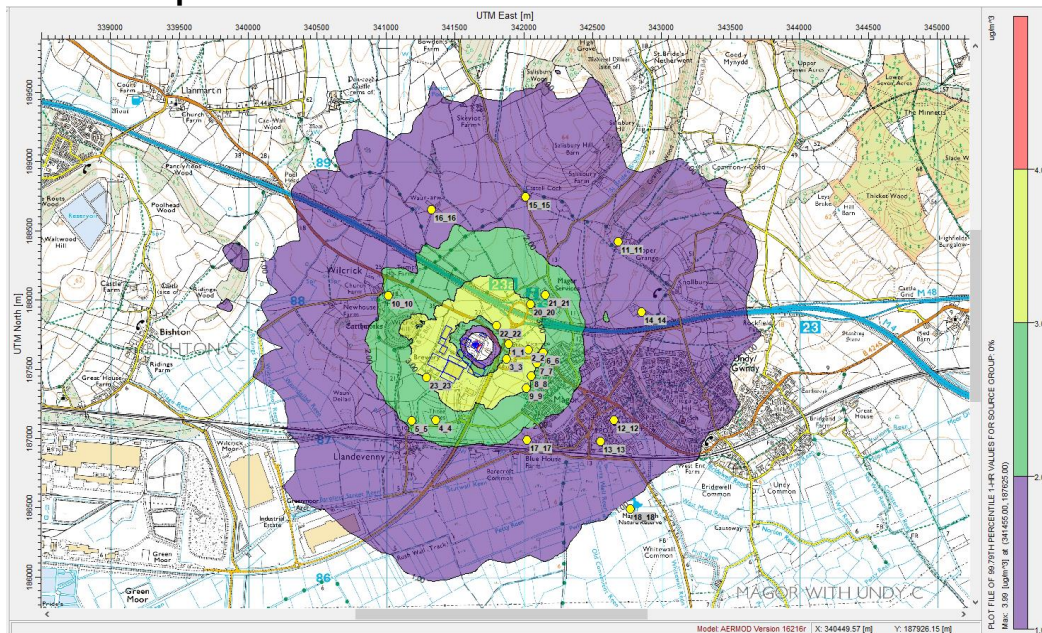

### 1hr 99.7th percentile levels Boiler 2 and Flue Ace 50%

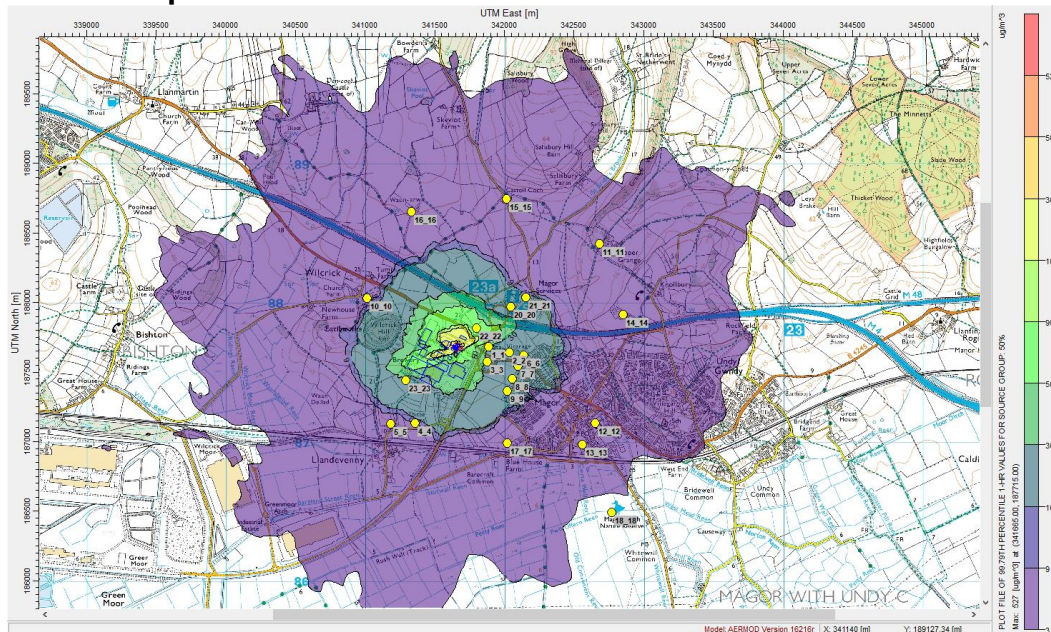

### 1hr 99.7th percentile levels Boiler 2 and Flue Ace 100%

